

7. ENGINE REMOVAL/INSTALLATION

SERVICE INFORMATION

7-2

ENGINE INSTALLATION

7-6

ENGINE REMOVAL

7-3

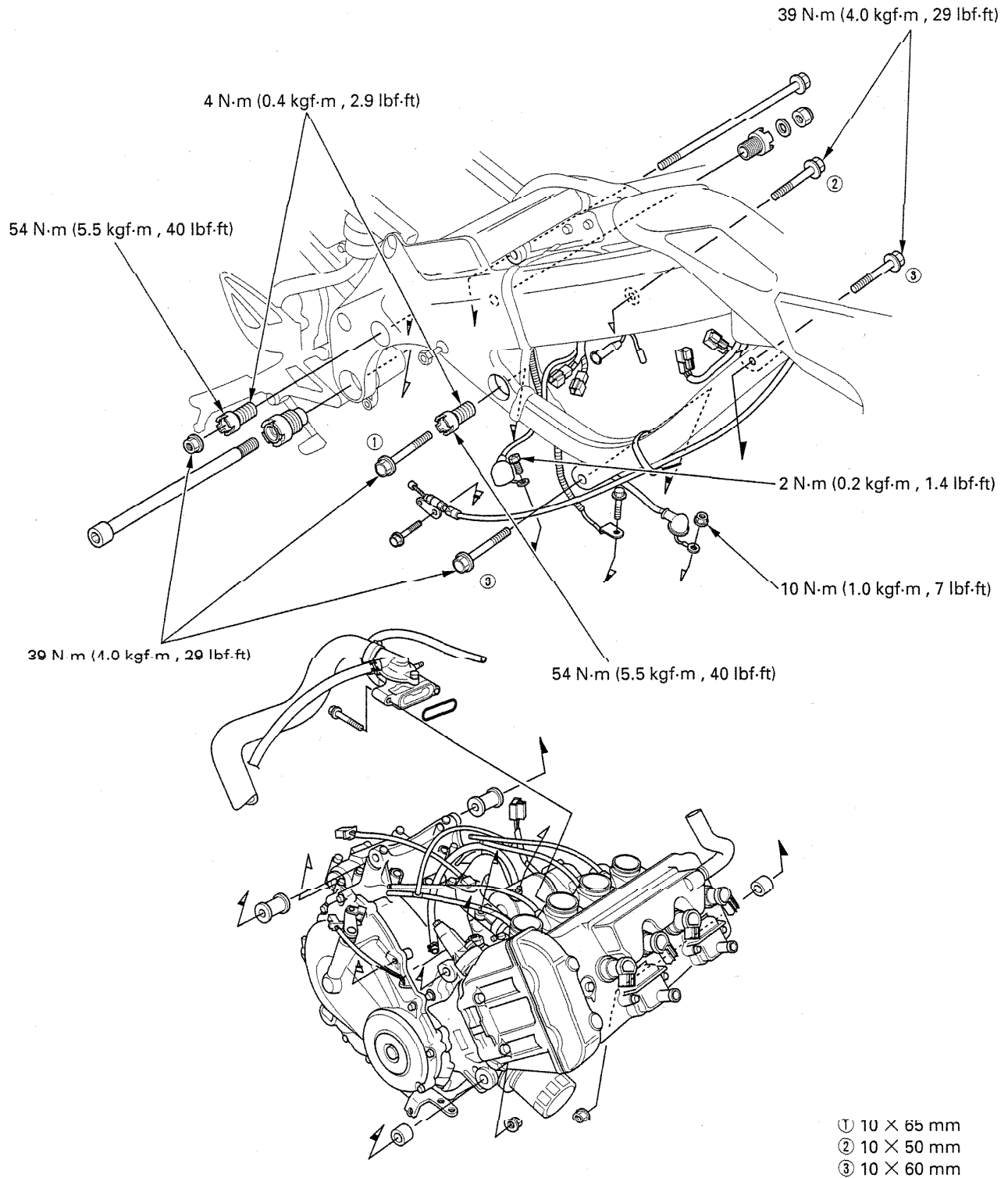

ENGINE REMOVAL/INSTALLATION

SERVICE INFORMATION

GENERAL

- A hoist or equivalent is required to support the motorcycle when removing and installing the engine.
- A floor jack or other adjustable support is required to support and maneuver the engine.

CAUTION:

Do not use the oil filter as a jacking point.

- When using the lock nut wrench for the adjusting bolt lock nut, use a deflecting beam type torque wrench 20 inches long. The lock nut wrench increases the torque wrench's leverage, so the torque wrench reading will be less than the torque actually applied to the lock nut. The specification given is the actual torque applied to the lock nut, not the reading on the torque wrench. Do not overtighten the lock nut. The specification later in the text gives both actual and indicated.
- The following components require engine removal for service:
 - transmission (section 11)
 - crankshaft/piston/cylinder (section 12)
- When installing the engine, be sure to tighten the engine mounting fasteners to the specified torque in the specified sequence. If you mistake the tightening torque or sequence, loosen all mounting fasteners, then tighten them again to the specified torque in the correct sequence.

SPECIFICATIONS

ITEM	SPECIFICATIONS
Engine dry weight	59 kg (130 lbs)
Engine oil capacity after disassembly	3.7 ℓ (3.9 US qt, 3.3 Imp qt)
Coolant capacity (radiator and engine)	2.7 ℓ (2.9 US qt, 2.4 Imp qt)

TORQUE VALUES

Front engine hanger bolt	39 N·m (4.0 kgf·m, 29 lbf·ft)
Center engine hanger bolt	39 N·m (4.0 kgf·m, 29 lbf·ft)
Center engine hanger adjusting bolt (right side)	4 N·m (0.4 kgf·m, 2.9 lbf·ft)
Center engine hanger lock nut (right side)	54 N·m (5.5 kgf·m, 40 lbf·ft)
Rear engine hanger nut	39 N·m (4.0 kgf·m, 29 lbf·ft)
Rear engine hanger adjusting bolt (right side)	4 N·m (0.4 kgf·m, 2.9 lbf·ft)
Rear engine hanger lock nut (right side)	54 N·m (5.5 kgf·m, 40 lbf·ft)
Shock link bracket nut	39 N·m (4.0 kgf·m, 29 lbf·ft)
Shock link-to-bracket nut	44 N·m (4.5 kgf·m, 33 lbf·ft)
Drive sprocket bolt	54 N·m (5.5 kgf·m, 40 lbf·ft)
Starter motor terminal nut	10 N·m (1.0 kgf·m, 7 lbf·ft)
Oil pressure switch terminal screw	2 N·m (0.2 kgf·m, 1.4 lbf·ft)

TOOL

Lock nut wrench	07VMA-MBB0100
-----------------	---------------

ENGINE REMOVAL

Drain the engine oil (page 3-12).

Remove the following:

- radiator (page 6-8)
- radiator reserve tank (page 6-11)
- exhaust system (page 2-7)
- carburetor (page 5-15)
- pulse secondary air injection (PAIR) control valve (page 5-39)
- EVAP canister (California only; page 5-39)
- direct ignition coil connectors.

Remove the two bolts and radiator stay.

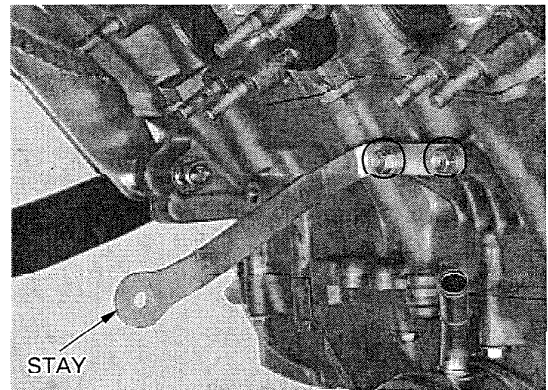

Remove the cable holder bolt and disconnect the clutch cable from the clutch arm.

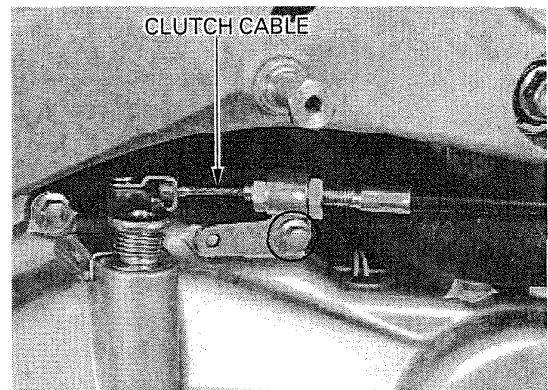

Remove the two bolts and thermostat housing.
Remove the O-ring.

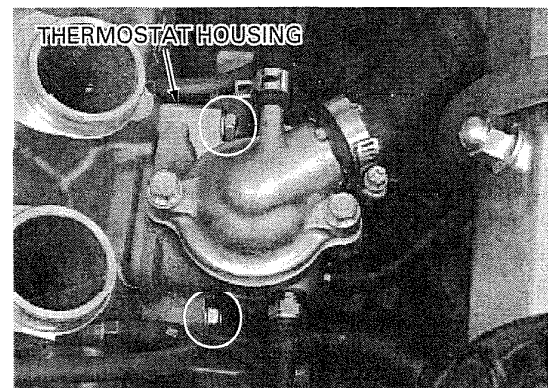

ENGINE REMOVAL/INSTALLATION

Disconnect the following:

- ignition pulse generator 2P (Red) connector
- speed sensor 3P (Black) connector
- oil pressure switch wire by removing screw
- starter motor cable by removing terminal nut
- ground cable by removing motor mounting bolt
- thermosensor connector

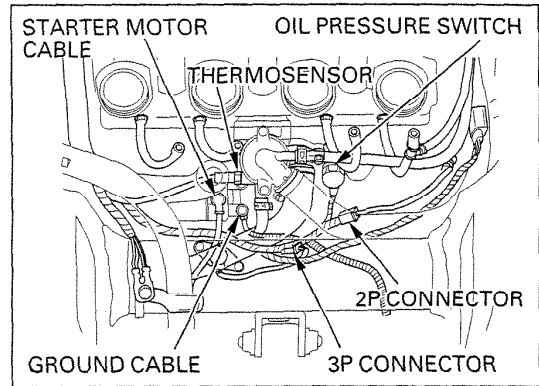

- alternator 3P (White) connector
- side stand 2P (Green) connector

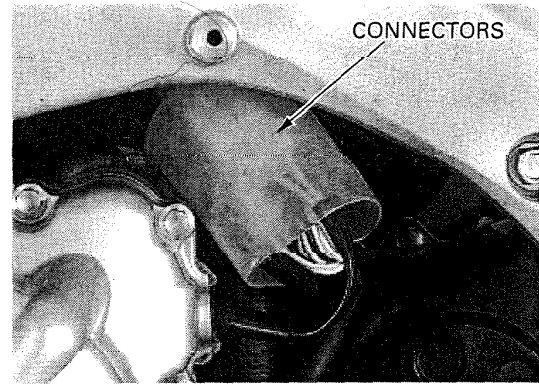

- gearshift arm by removing bolt
- neutral switch connector

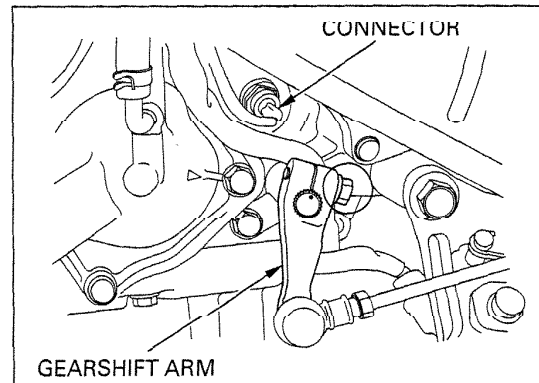

Remove the two bolts, sprocket cover and guide plate.

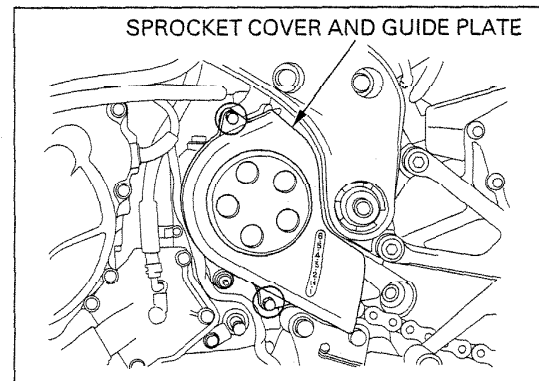

ENGINE REMOVAL/INSTALLATION

Loosen the rear axle nut and drive chain adjusters. Remove the drive sprocket bolt, washer and the drive sprocket with the drive chain from the countershaft.

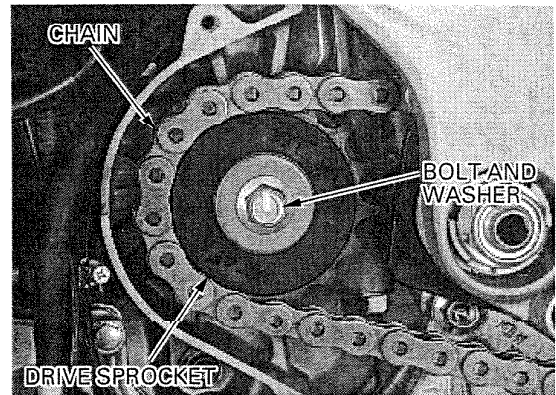

Support the motorcycle securely with a hoist or equivalent.

Remove the following:

- shock link-to-bracket nut and bolt
- shock link bracket nuts and bolts

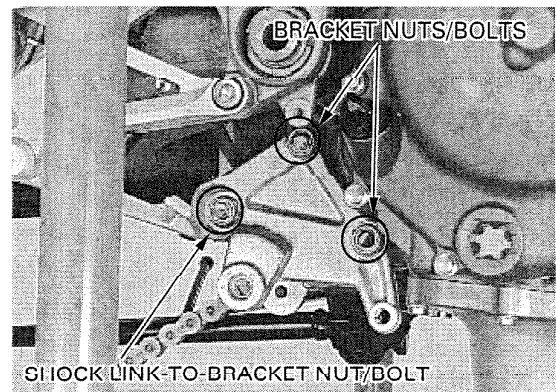

- shock link brackets from engine and shock link
- four dowel pins.

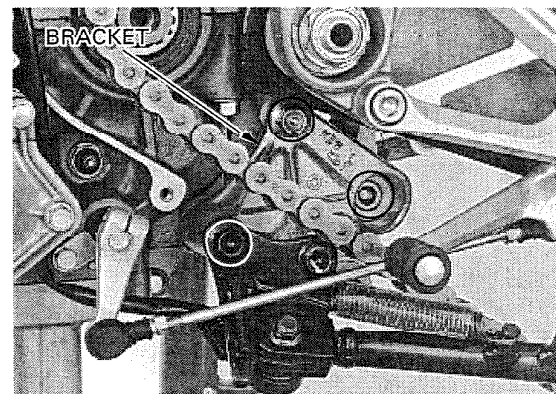

Support the swingarm securely.

Loosen the left and right swingarm pivot lock nuts (page 14-13).

Remove the pivot nut and washer, and the pivot bolt.

Place a floor jack or other adjustable support under the engine.

NOTE:

The jack height must be continually adjusted to relieve stress for ease of bolt removal.

Remove the following:

- front hanger bolts and spacers (both sides)
- center hanger bolt (left side).

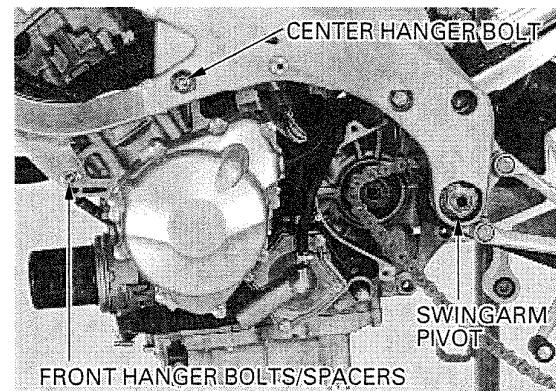

ENGINE REMOVAL/INSTALLATION

Hold the center hanger bolt (right side) and loosen the lock nut using the special tool.

TOOL:

Lock nut wrench 07VMA-MBB0100

Hold the rear hanger nut and loosen the lock nut using the same tool.

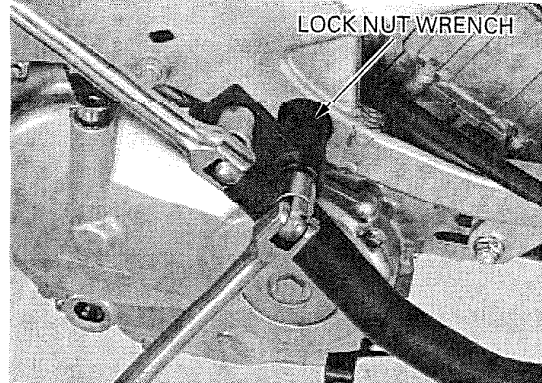

Remove the following:

- center hanger bolt (right side)
- rear hanger nut, bolt and spacers
- lock nuts and adjusting bolts
- engine from the frame.

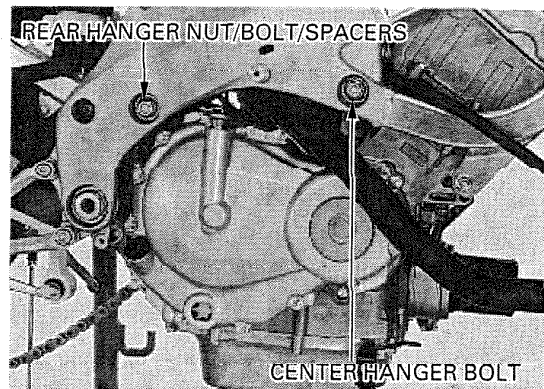

ENGINE INSTALLATION

NOTE:

- When tightening the lock nut with the lock nut wrench, refer to torque wrench reading information on page 7-2 "SERVICE INFORMATION".
- The jack height must be continually adjusted to relieve stress from the mounting fasteners.
- Route the wires and cables properly (page 1-18).

CAUTION:

Be sure to tighten all engine mounting fasteners to the specified torque in the specified sequence described following page. If you mistake the tightening torque or sequence, loosen all mounting fasteners, then tighten them again to the specified torque in the specified sequence.

ENGINE REMOVAL/INSTALLATION

Carefully align the hanger bolt holes in the frame and engine.

Install the engine into the frame and swingarm.
Install the following:

- center hanger bolt (B)
- front hanger bolts (A) and (D) with spacers

1. Tighten the center hanger bolt (B).

TORQUE : 39 N·m (4.0 kgf·m , 29 lbf·ft)

2. Tighten the front hanger bolt (A).

TORQUE : 39 N·m (4.0 kgf·m , 29 lbf·ft)

3. Tighten the front hanger bolt (D).

TORQUE : 39 N·m (4.0 kgf·m , 29 lbf·ft)

4. Install the center adjusting bolt (E) until it just contacts to the engine. Tighten the adjusting bolt (E) to the specified torque, then turn it out 180°.

TORQUE : 4 N·m (0.4 kgf·m , 2.9 lbf·ft)

5. Install the lock nut (E). Hold the adjusting bolt (E) and tighten the lock nut (E).

TOOL:

Lock nut wrench 07VMA-MBB0100

TORQUE : **Actual:** 54 N·m (5.5 kgf·m , 40 lbf·ft)
Indicated: 49 N·m (5.0 kgf·m , 36 lbf·ft)

6. Set the right spacer (F) between the frame and engine (Temporarily install the rear hanger bolt (C) to align the spacer). Install the adjusting bolt (F) until it just contacts to the spacer. Remove the hanger bolt (C) and tighten the rear adjusting bolt (F) to the specified torque, then turn it out 180°.

TORQUE : 4 N·m (0.4 kgf·m , 2.9 lbf·ft)

7. Install the lock nut (F). Hold the adjusting bolt (F) and tighten the lock nut (F).

TOOL:

Lock nut wrench 07VMA-MBB0100

TORQUE : **Actual:** 54 N·m (5.5 kgf·m , 40 lbf·ft)
Indicated: 49 N·m (5.0 kgf·m , 36 lbf·ft)

8. Install the center hanger bolt (E) and tighten it.

TORQUE : 39 N·m (4.0 kgf·m , 29 lbf·ft)

9. Install the rear hanger bolt (C) from the left side with the left spacer.
Install the rear hanger nut (F) and tighten it.

TORQUE : 39 N·m (4.0 kgf·m , 29 lbf·ft)

10. Install the swingarm pivot bolt (page 14-17).

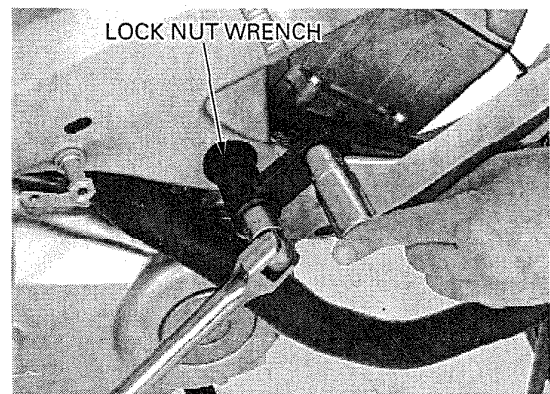
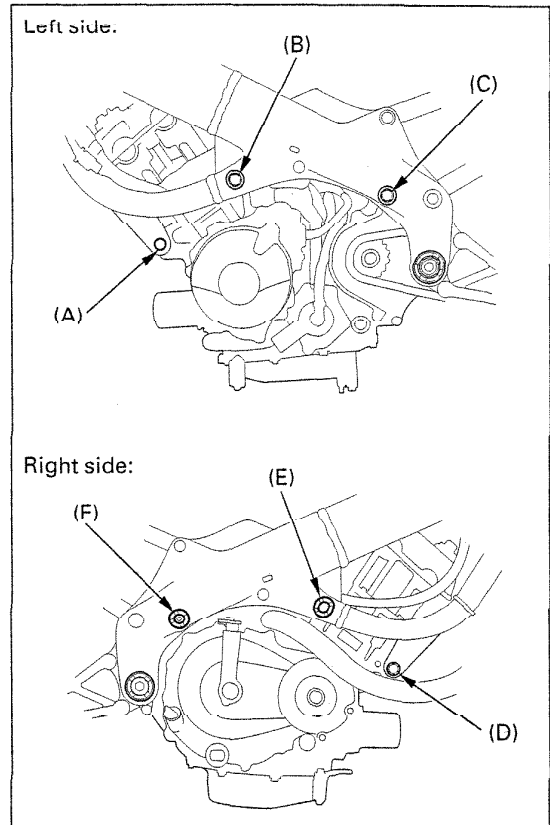

ENGINE REMOVAL/INSTALLATION

Install the four dowel pins into the bracket bolt holes in the engine.

Install the link brackets onto the engine and set the shock link between the brackets.

Carefully align the bolt holes in the brackets and shock link.

Install the bracket bolts and shock link-to-bracket bolt from the left side.

Install the bracket and shock link-to-bracket nuts. Tighten the bracket nuts, then the shock link-to-bracket nut.

TORQUE :

Bracket nut: 39 N·m (4.0 kgf·m , 29 lbf·ft)

Shock link-to-bracket: 44 N·m (4.5 kgf·m , 33 lbf·ft)

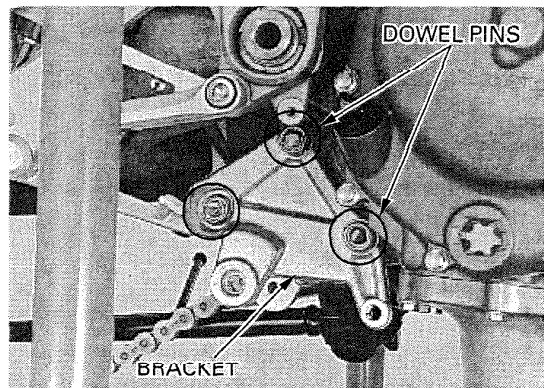
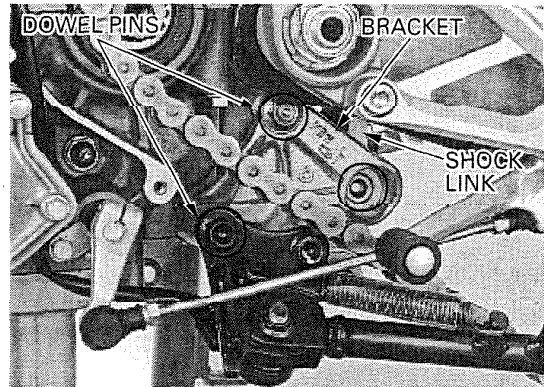

Install with the sprocket's mark facing out.

Install the drive sprocket with the drive chain onto the countershaft.

Install the washer and bolt, and tighten the bolt.

TORQUE : 54 N·m (5.5 kgf·m , 40 lbf·ft)

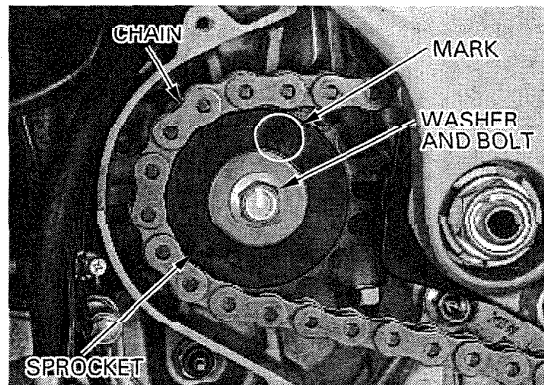

Install the drive sprocket cover with the guide plate and tighten the two bolts.

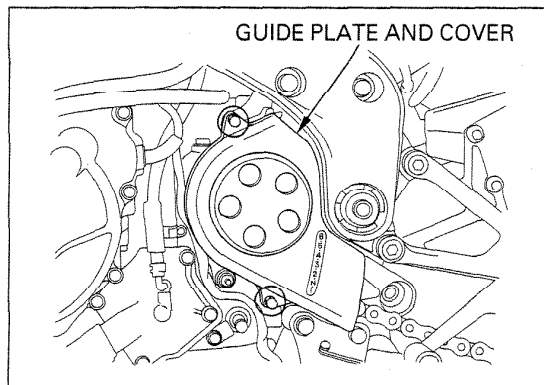

ENGINE REMOVAL/INSTALLATION

Install the gearshift arm onto the spindle by aligning the slit of the arm with the punch mark on the spindle.
Tighten the pinch bolt.

Connect the following:
— neutral switch connector

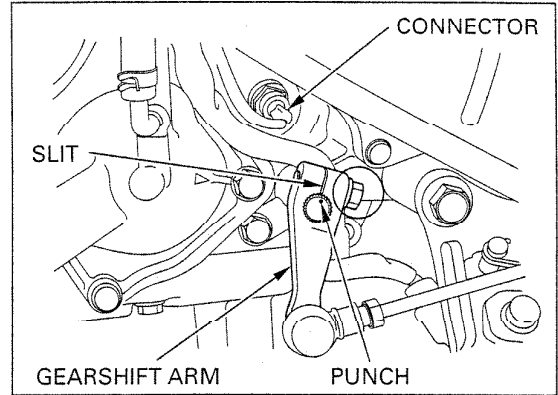

— side stand 2P (Green) connector
— alternator 3P (White) connector

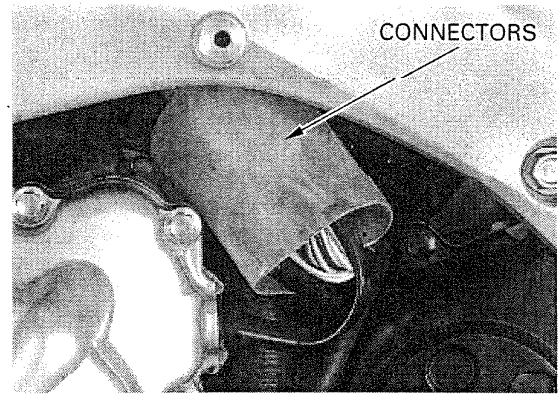

— starter motor cable

TORQUE : 10 N·m (1.0 kgf·m , 7 lbf·ft)

— ground cable
— oil pressure switch wire

TORQUE : 2 N·m (0.2 kgf·m , 1.4 lbf·ft)

— speed sensor 3P (Black) connector
— ignition pulse generator 2P (Red) connector
— thermosensor connector

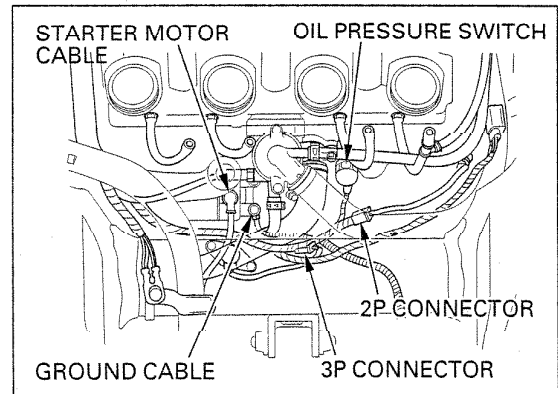

Install a new O-ring into the thermostat housing groove.

Install the thermostat housing onto the cylinder head and tighten the two bolts.

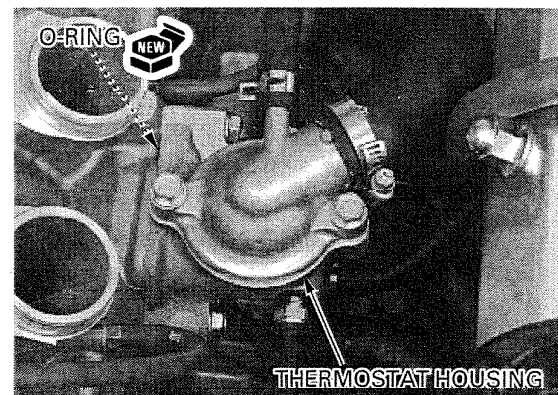

ENGINE REMOVAL/INSTALLATION

Connect the clutch cable to the clutch arm and install the cable holder, then tighten the holder bolt.

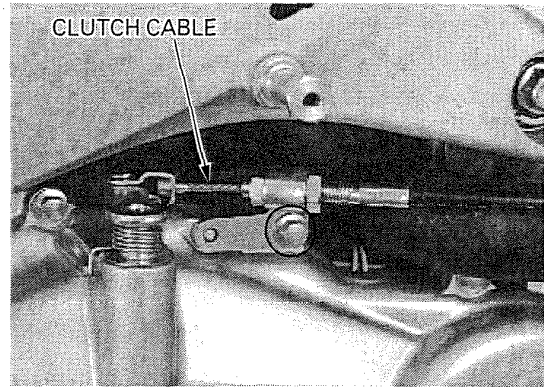

Install the radiator stay and tighten the two bolts.

Install the following:

- direct ignition coil connectors
- EVAP canister (California only; page 5-39)
- pulse secondary air injection (PAIR) control valve (page 5-39)
- carburetor (page 5-30)
- exhaust system (page 2-7)
- radiator reserve tank (page 6-11)
- radiator (page 6-8).

Adjust the following:

- drive chain slack (page 3-16)
- clutch lever free play (page 3-23).

Fill the crankcase with recommended engine oil (page 3-12)

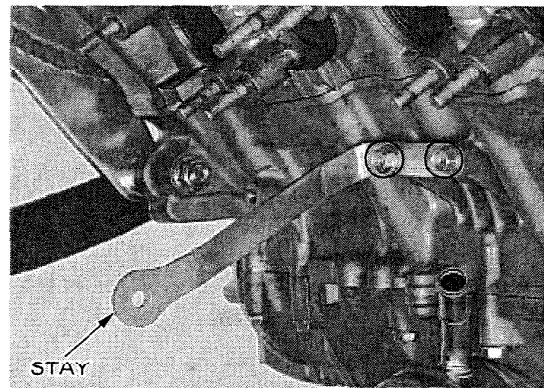

MEMO

CYLINDER HEAD/VALVE

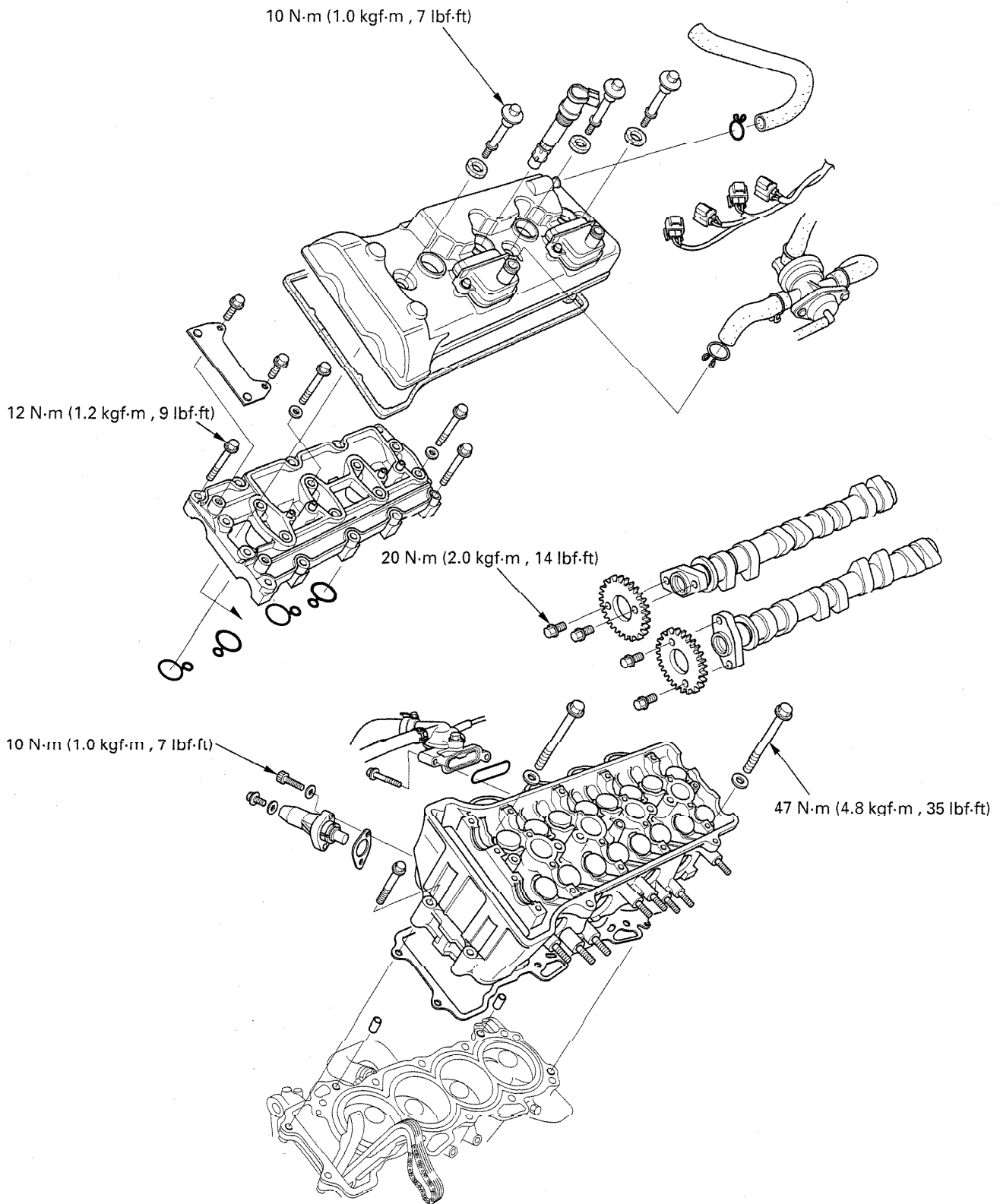

8. CYLINDER HEAD/VALVE

SERVICE INFORMATION	8-1	VALVE GUIDE REPLACEMENT	8-12
TROUBLESHOOTING	8-2	VALVE SEAT INSPECTION/REFACING	8-13
CYLINDER COMPRESSION	8-3	CYLINDER HEAD ASSEMBLY	8-16
CYLINDER HEAD COVER REMOVAL	8-3	CYLINDER HEAD INSTALLATION	8-17
CAMSHAFT REMOVAL	8-4	CAMSHAFT INSTALLATION	8-19
CYLINDER HEAD REMOVAL	8-7	CYLINDER HEAD COVER INSTALLATION	8-21
CYLINDER HEAD DISASSEMBLY	8-8		

SERVICE INFORMATION

GENERAL

- This section covers service of the camshafts, cylinder head and valves.
- The camshafts, cylinder head and valves can be serviced with the engine installed in the frame.
- When disassembling, mark and store the disassembled parts to ensure that they are reinstalled in their original locations.
- Clean all disassembled parts with cleaning solvent and dry them by blowing them off with compressed air before inspection.
- Camshaft lubricating oil is fed through oil passages in the cylinder head. Clean the oil passages before assembling cylinder head.
- Be careful not to damage the mating surfaces when removing the cylinder head cover and cylinder head.

SPECIFICATIONS

Unit: mm (in)

ITEM			STANDARD	SERVICE LIMIT	
Cylinder compression at 350 rpm			1,226 kPa (12.5 kgf/cm ² , 178 psi)	—	
Valve clearance			IN	0.20 ± 0.03 (0.008 ± 0.001)	
			EX	0.28 ± 0.03 (0.011 ± 0.001)	
Camshaft	Cam lobe height	49 state/Canada type	IN	36.600–36.760 (1.4409–1.4472)	36.57 (1.440)
			EX	35.380–35.540 (1.3929–1.3992)	35.35 (1.392)
		California type	IN	34.640–34.720 (1.3638–1.3669)	34.61 (1.363)
			EX	33.920–34.000 (1.3354–1.3386)	33.89 (1.334)
	Runout				0.05 (0.002)
	Oil clearance			0.020–0.062 (0.0008–0.0024)	0.10 (0.004)
Valve lifter	Valve lifter O.D.		25.978–25.993 (1.0228–1.0233)	25.97 (1.022)	
	Valve lifter bore I.D.		26.010–26.026 (1.0240–1.0246)	26.04 (1.025)	
Valve, valve guide	Valve stem O.D.	IN	3.975–3.990 (0.1565–0.1571)	3.965 (0.1561)	
		EX	3.965–3.980 (0.1561–0.1567)	3.955 (0.1557)	
	Valve guide I.D.		IN/EX	4.000–4.012 (0.1575–0.1580)	4.01 (0.159)
	Stem-to-guide clearance		IN	0.010–0.037 (0.0004–0.0015)	0.075 (0.0030)
			EX	0.020–0.047 (0.0008–0.0019)	0.085 (0.0033)
	Valve guide projection above cylinder head		IN	16.1–16.4 (0.63–0.65)	—
		EX	14.3–14.6 (0.56–0.57)	—	
Valve seat width		IN/EX	0.90–1.10 (0.035–0.043)	1.5 (0.06)	
Valve spring	Free length		IN	39.87 (1.570)	38.27 (1.507)
			EX	36.23 (1.426)	34.73 (1.367)
Cylinder head warpage				0.10 (0.004)	

CYLINDER HEAD/VALVE

TORQUE VALUES

Cam chain tensioner pivot bolt	10 N·m (1.0 kgf·m , 7 lbf·ft)	Apply locking agent to the threads
Cam chain guide washer bolt	12 N·m (1.2 kgf·m , 9 lbf·ft)	
Cylinder head bolt (9 mm)	47 N·m (4.8 kgf·m , 35 lbf·ft)	Apply molybdenum oil solution to the threads and seating surface
Camshaft holder bolt	12 N·m (1.2 kgf·m , 9 lbf·ft)	Apply oil to the threads and seating surface
Cam sprocket bolt	20 N·m (2.0 kgf·m , 14 lbf·ft)	Apply locking agent to the threads
Cylinder head cover bolt	10 N·m (1.0 kgf·m , 7 lbf·ft)	
Cam chain tensioner lifter mounting bolt	10 N·m (1.0 kgf·m , 7 lbf·ft)	
Spark plug	12 N·m (1.2 kgf·m , 9 lbf·ft)	

TOOLS

Compression gauge attachment	07RMJ-MY50100	
Valve spring compressor	07757-0010000	
Valve spring compressor attachment	07959-KM30101	
Tappet hole protector	07HMG-MR70002	
Valve guide driver	07JMD-KY20100	
Valve guide reamer, 4.008 mm	07MMH-MV90100	
Valve seat cutter, 27.5 mm (IN 45°)	07780-0010200	or equivalent commercially available in U.S.A.
Valve seat cutter, 24.5 mm (EX 45°)	07780-0010100	
Flat cutter, 27 mm (IN 32°)	07780-0013300	
Flat cutter, 24 mm (EX 32°)	07780-0012500	
Interior cutter, 26 mm (IN 60°)	07780-0014500	
Interior cutter, 22 mm (EX 60°)	07780-0014202	
Cutter holder, 4.0 mm	07781-0010500	

TROUBLESHOOTING

Engine top-end problems usually affect engine performance. These can be diagnosed by a compression test, or by tracing top-end noise with a sounding rod or stethoscope.

Compression too low, hard starting or poor performance at low speed

- Valves
 - Incorrect valve adjustment
 - Burned or bent valves
 - Incorrect valve timing
 - Broken valve spring
 - Uneven valve seating
- Cylinder head
 - Leaking or damaged cylinder head gasket
 - Warped or cracked cylinder head
 - Loose spark plug
- Cylinder/piston problem (section 12)

Compression too high

- Excessive carbon build-up on piston head or combustion chamber

Excessive smoke

- Worn valve stem or valve guide
- Damaged stem seal
- Cylinder/piston problem (section 12)

Excessive noise

- Incorrect valve clearance
- Sticking valve or broken valve spring
- Worn or damaged camshaft
- Worn or damaged valve lifter
- Worn cam chain
- Worn or damaged cam chain tensioner
- Worn cam sprocket teeth
- Cylinder/piston problem (section 12)

Rough idle

- Low cylinder compression

CYLINDER COMPRESSION

Warm up the engine to normal operating temperature.

Stop the engine and remove the direct ignition coils (page 3-6).

Install the compression gauge with the gauge attachment.

TOOL:

Compression gauge attachment 07RMJ-MY50100

Shift the transmission in neutral.

Open the throttle all the way and crank the engine with the starter motor until the gauge reading stops rising. The maximum reading is usually reached within 4–7 seconds.

COMPRESSION PRESSURE:

1,226 kPa (12.5 kgf/cm², 178 psi)

Low compression can be caused by:

- blown cylinder head gasket
- improper valve adjustment
- valve leakage
- worn piston ring or cylinder

High compression can be caused by:

- carbon deposits in combustion chamber or on piston head

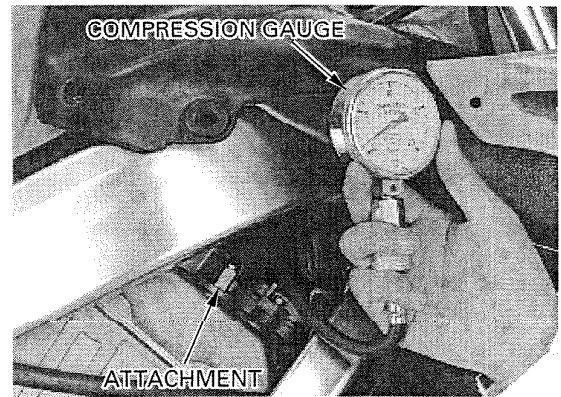

CYLINDER HEAD COVER REMOVAL

Remove the carburetor (page 5-15).

Disconnect the ignition coil 2P connectors and remove the direct ignition coils.

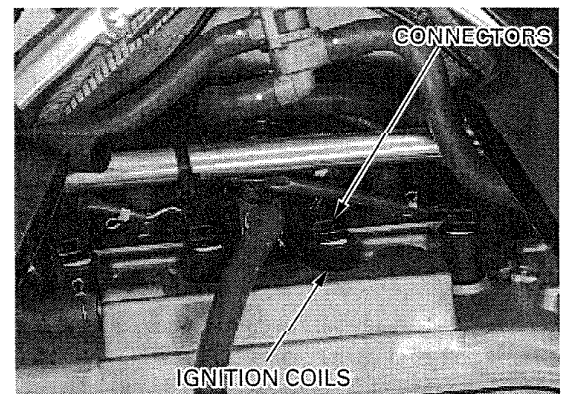

Disconnect the air supply hoses and the vacuum tube to remove the pulse secondary air injection (PAIR) control valve.

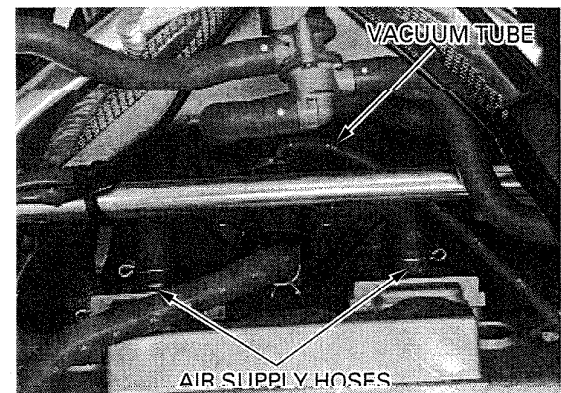

CYLINDER HEAD/VALVE

Remove the three bolts and the cylinder head cover.

NOTE:

Do not remove the dowel pins and the breather plate from the head cover.

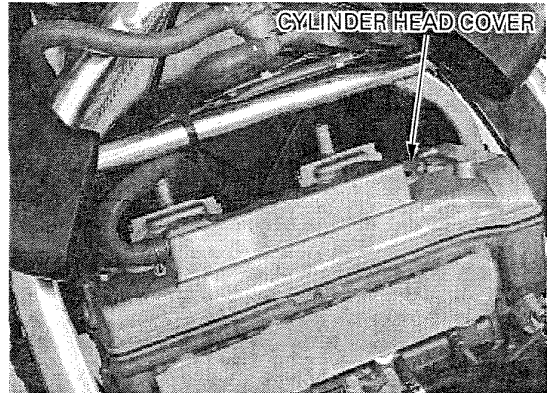

CAMSHAFT REMOVAL

Remove the cylinder head cover (page 8-3).

Remove the cam chain tensioner lifter sealing bolt and sealing washer.

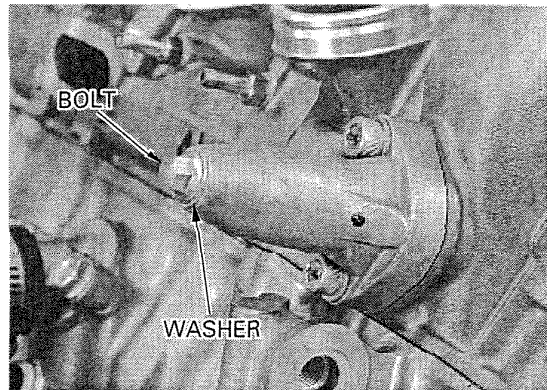

Turn the cam chain tensioner lifter shaft clockwise fully and secure it with a stopper tool. This tool can easily be made from a thin (1 mm of thickness) piece of steel as shown below.

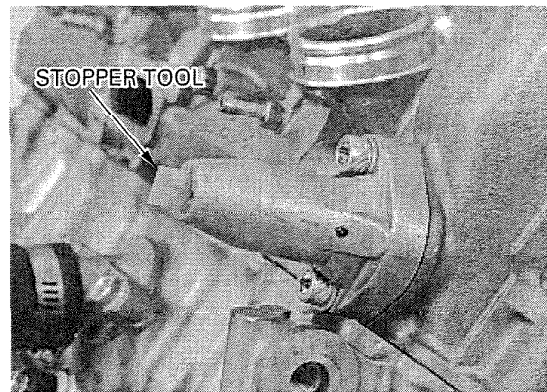
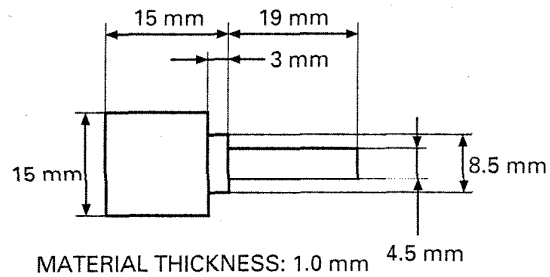

Remove the two bolts and cam chain guide plate from the camshaft holder.

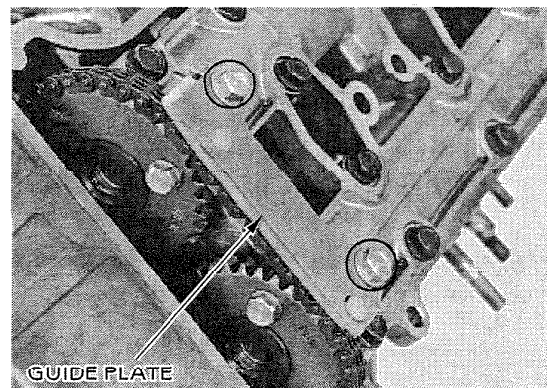

Remove the timing hole cap.

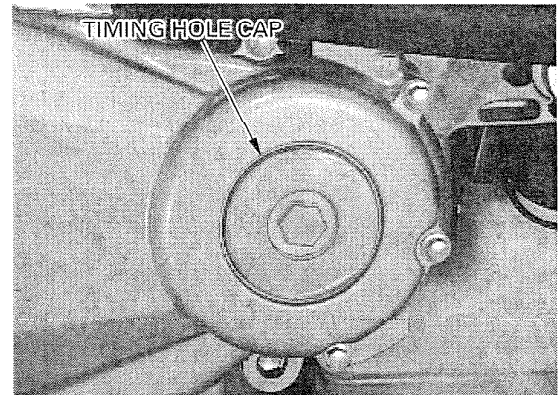

Be careful not to drop the sprocket bolts and cam sprockets into the crankcase.

Remove the cam sprocket bolts from the intake and exhaust camshafts. Turn the crankshaft clockwise one turn, and remove the other cam sprocket bolts.

Remove the cam sprockets from the camshafts, and suspend the cam chain with a piece of wire to prevent it from falling into the crankcase.

To replace the cam chain, remove the cam chain tensioner and guide (page 8-11).

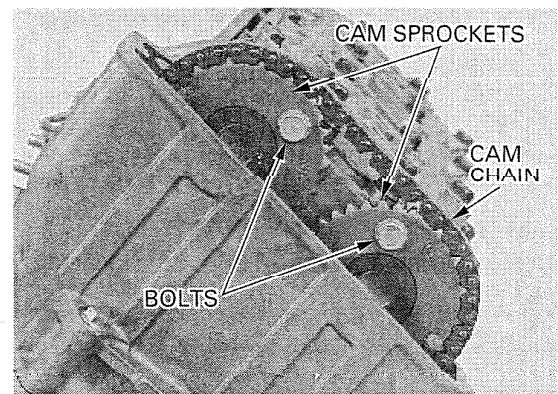

Loosen the camshaft holder bolts in a crisscross pattern in several steps from the outside to inside to prevent damage the camshaft holder and camshafts.

Remove the camshaft holder.

Remove the camshafts.

NOTE:

Do not forcibly remove the dowel pins from the camshaft holder

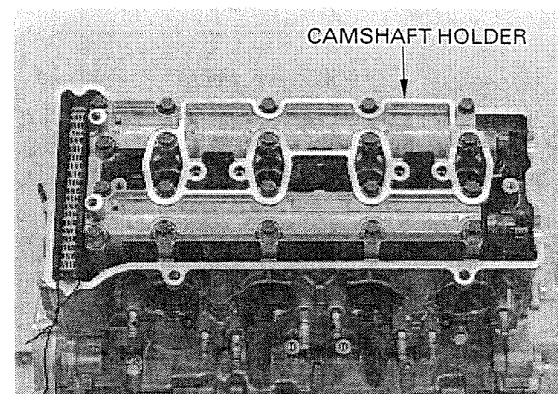

Remove the valve lifters and shims.

NOTE:

- Be careful not to damage the valve lifter bore.
- Shims may stick to the inside of the valve lifter. Do not allow the shims to fall into the crankcase.
- Mark all valve lifters and shims to ensure correct reassembly in their original locations.
- The valve lifter can be easily removed with a valve lapping tool or magnet.
- The shims can be easily removed with tweezers or a magnet.

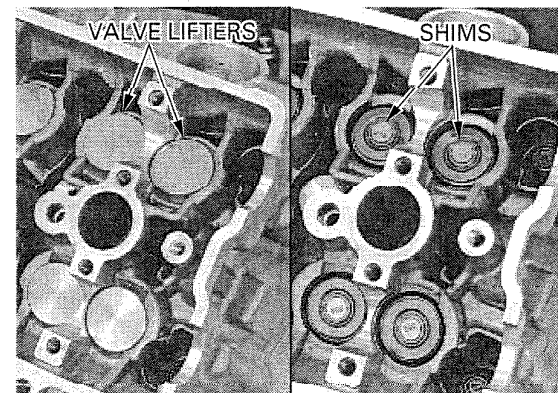

CYLINDER HEAD/VALVE

INSPECTION

CAMSHAFT

Check the cam and journal surfaces of the camshaft for scoring, scratches or evidence of insufficient lubrication.

Check the oil holes in the camshaft for clogging.

Measure the camshaft runout using a dial indicator.

SERVICE LIMIT: 0.05 mm (0.002 in)

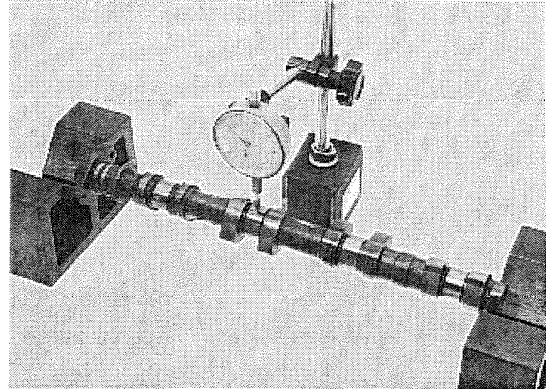

Measure each cam lobe height using a micrometer.

SERVICE LIMITS:

49 state/Canada type: IN: 36.57 mm (1.440 in)

EX: 35.35 mm (1.392 in)

California type: IN: 34.61 mm (1.363 in)

EX: 33.89 mm (1.334 in)

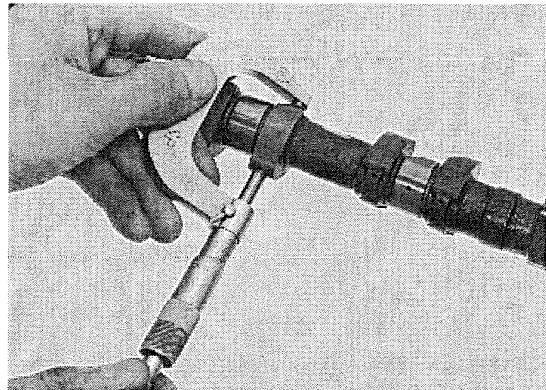

CAMSHAFT JOURNAL

Check the camshaft journal surfaces of the camshaft holders and cylinder head for scoring, scratches or evidence of insufficient lubrication.

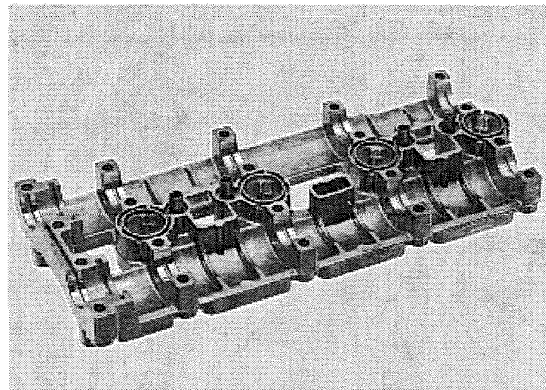

CAM CHAIN GUIDE PLATE

Check the guide plate for excessive wear or damage and replace it if necessary.

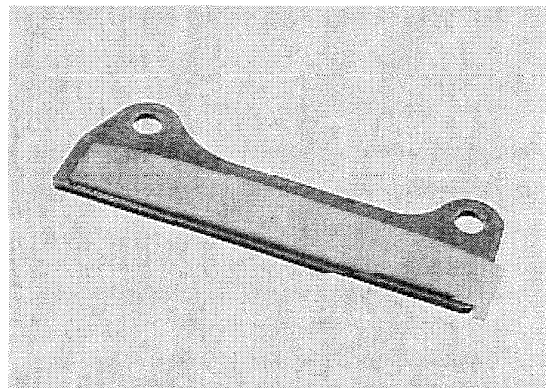

CYLINDER HEAD/VALVE

—two bolts, washers and cam chain tensioner lifter.

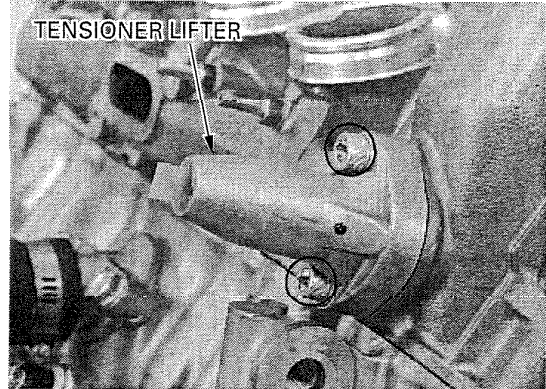

Remove the two 6 mm cylinder head bolts.
Loosen the ten 9 mm cylinder head bolts in a criss-cross pattern in 2 or 3 steps, and remove them.

Remove the cylinder head.

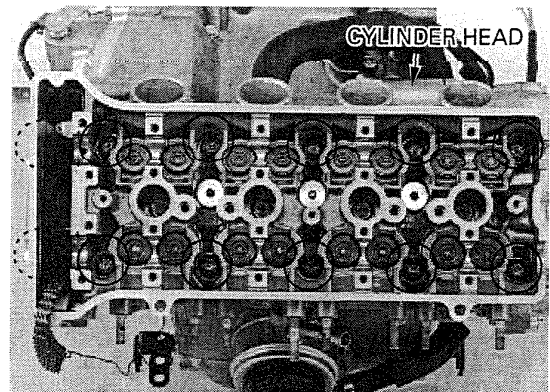

Remove the gasket and dowel pins.

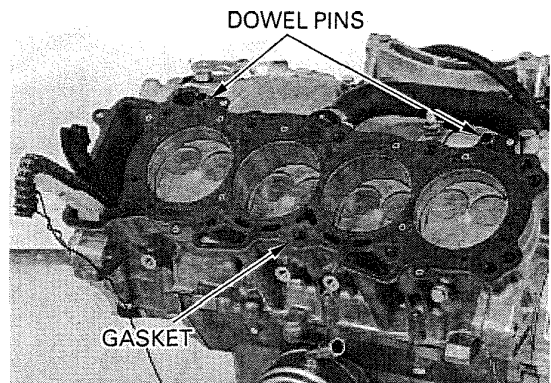

CYLINDER HEAD DISASSEMBLY

Remove the spark plugs from the cylinder head.

Install the tappet hole protector into the valve lifter bore.

TOOL:
Tappet hole protector 07HMG-MR70002

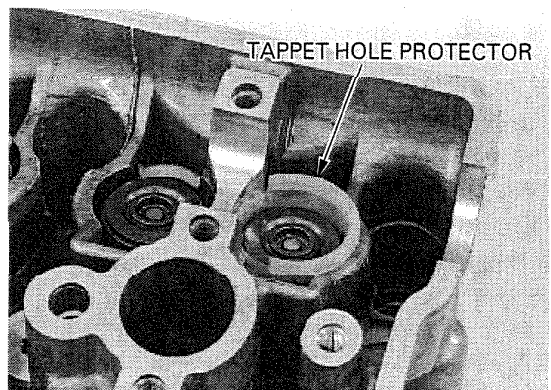

Remove the valve spring cotters using the special tools.

TOOLS:

Valve spring compressor 07757-0010000
Compressor attachment 07959-KM30101

CAUTION:

To prevent loss of tension, do not compress the valve springs more than necessary to remove the cotters.

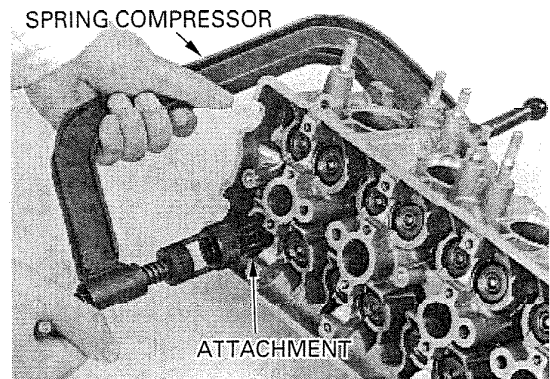

Remove the following:

- spring retainer
- valve springs
- valve
- stem seal
- spring seats

NOTE:

Mark all parts during disassembly so they can be placed back in their original locations.

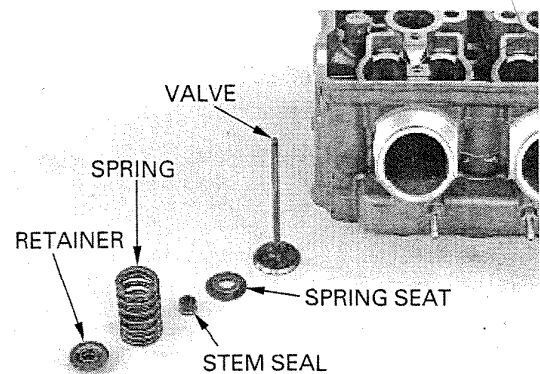

INSPECTION

CYLINDER HEAD

Remove the carbon deposits from the combustion chamber, being careful not to damage the gasket surface.

Check the spark plug hole and valve areas for cracks.

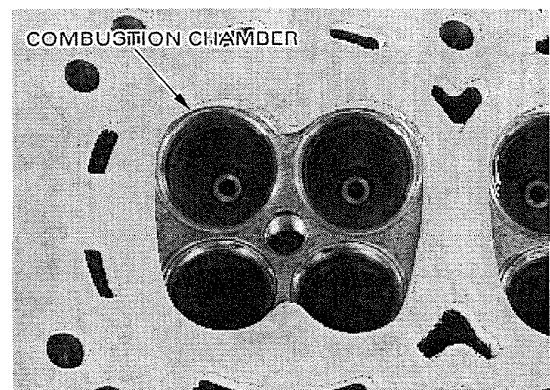

Check the cylinder head for warpage with a straight edge and feeler gauge.

SERVICE LIMIT: 0.10 mm (0.004 in)

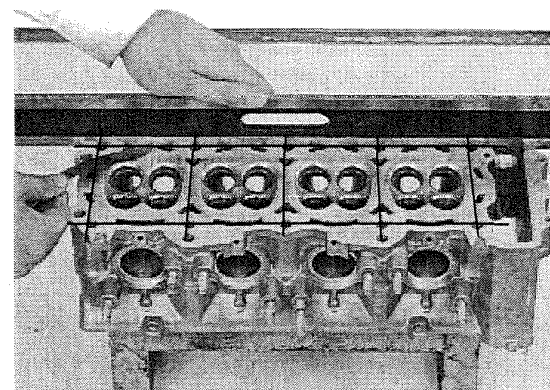

CYLINDER HEAD/VALVE

Check the valve lifter bore for scoring, scratches or damage.

Measure the each valve lifter bore I.D.

SERVICE LIMIT: 26.04 mm (1.025 in)

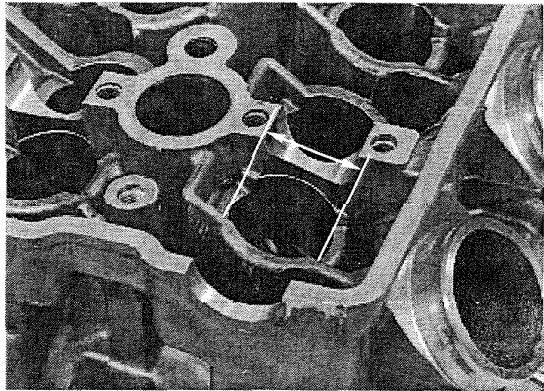

VALVE LIFTER

Check the valve lifter for scoring, scratches or damage.

Measure the each valve lifter O.D.

SERVICE LIMIT: 25.97 mm (1.022 in)

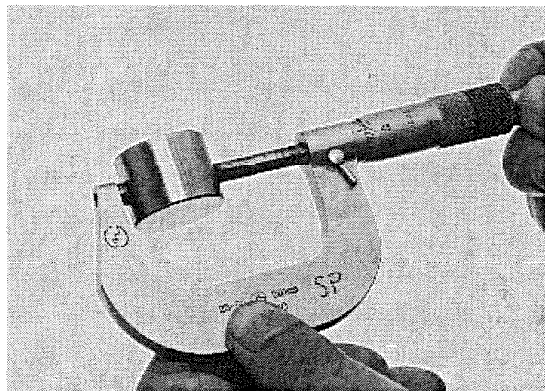

VALVE SPRING

Measure the valve spring free length.

SERVICE LIMITS: IN: 38.27 mm (1.507 in)

EX : 34.73 mm (1.367 in)

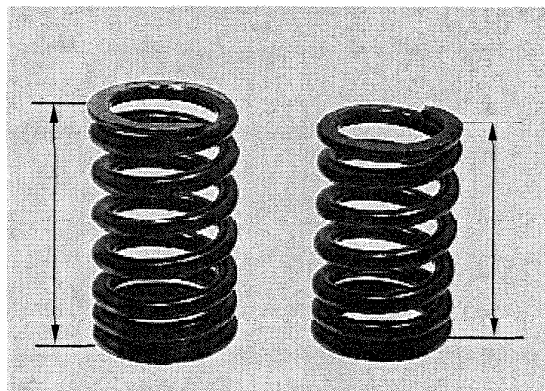

VALVE/VALVE GUIDE

Check that the valve moves smoothly in the guide.
Check the valve for bending, burning or abnormal wear.

Measure each valve stem O.D. and record it.

SERVICE LIMITS: IN: 3.965 mm (0.1561 in)

EX : 3.955 mm (0.1557 in)

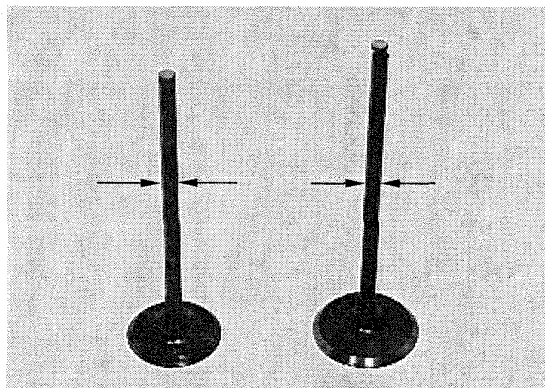

Ream the valve guide to remove any carbon build-up before measuring the guide. Insert the reamer from the combustion chamber side of the head and always rotate the reamer clockwise.

TOOL:
Valve guide reamer 07MMH-MV90100

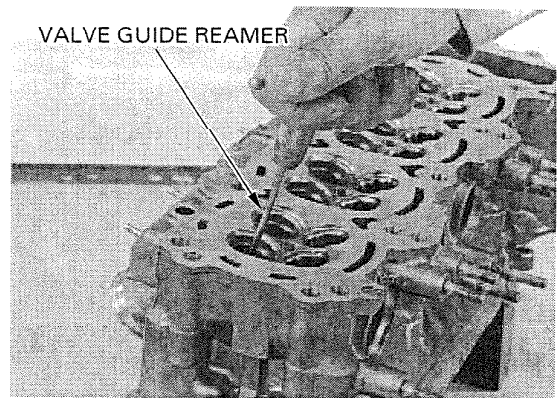

Measure each valve guide I.D. and record it.

SERVICE LIMIT: IN/EX: 4.04 mm (0.159 in)

Subtract each valve stem O.D. from the corresponding guide I.D. to obtain the stem-to-guide clearance.

SERVICE LIMIT: IN: 0.075 mm (0.0030 in)
EX : 0.085 mm (0.0033 in)

If the stem-to-guide clearance exceeds the service limit, determine if a new guide with standard dimensions would bring the clearance within tolerance. If so, replace any guides as necessary and ream to fit.

If the stem-to-guide clearance exceeds the service limit with a new guide, also replace the valve.

NOTE:

Inspect and reface the valve seats whenever the valve guides are replaced (page 8-12).

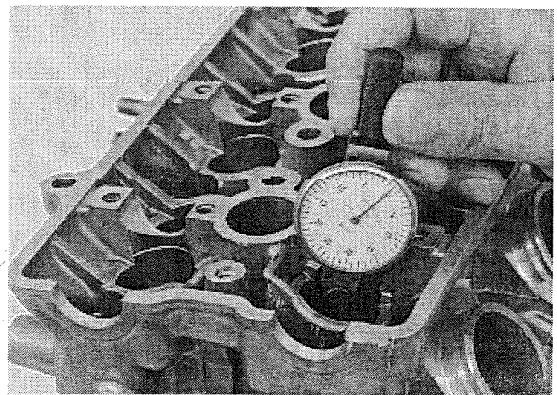

CAM CHAIN TENSIONER/GUIDE

Remove the right crankcase cover (page 9-3). Remove the socket bolt and the cam chain tensioner, then the washer (between the engine and tensioner). Remove the washer bolt and the cam chain guide.

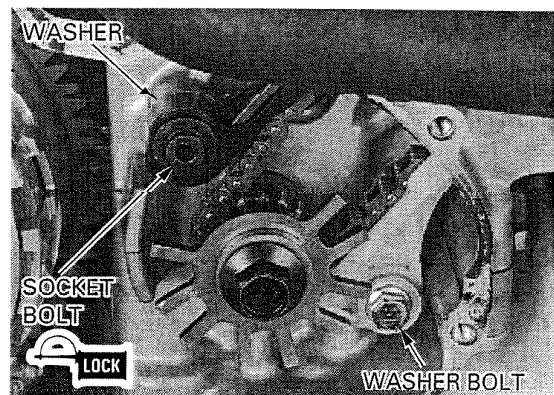

CYLINDER HEAD/VALVE

Check the cam chain tensioner and guide for excessive wear or damage and replace them if necessary.

Install the cam chain tensioner and guide in the reverse order of removal.

Apply locking agent to the tensioner (socket) bolt threads. **TORQUE: Tensioner:** 10 N·m (1.0 kgf·m, 7 lbf·ft)
Guide: 12 N·m (1.2 kgf·m, 9 lbf·ft)
Install the right crankcase cover (page 9-14).

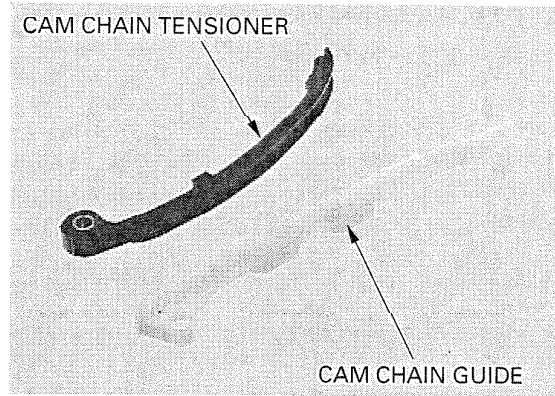

VALVE GUIDE REPLACEMENT

Chill new valve guides in the freezer section of a refrigerator for about an hour.

Heat the cylinder head to 130–140 °C (275–290 °F) with a hot plate or oven.

▲WARNING

Wear heavy gloves to avoid burns when handling the heated cylinder head.

CAUTION:

Using a torch to heat the cylinder head may cause warpage.

Support the cylinder head and drive the valve guides out of the cylinder head from the combustion chamber side.

TOOL:
Valve guide driver 07JMD-KY20100

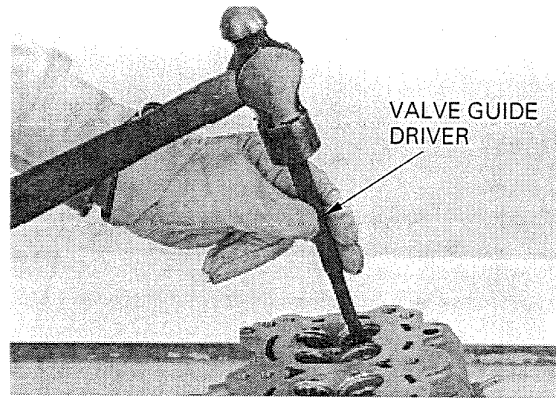

While the cylinder head is still heated, drive new valve guides in the cylinder head from the camshaft side until the exposed height is following dimensions.

TOOL:
Valve guide driver 07JMD-KY20100

VALVE GUIDE PROJECTION:
IN: 16.1–16.4 mm (0.63–0.65 in)
EX: 14.3–14.6 mm (0.56–0.57 in)

Let the cylinder head cool to room temperature.

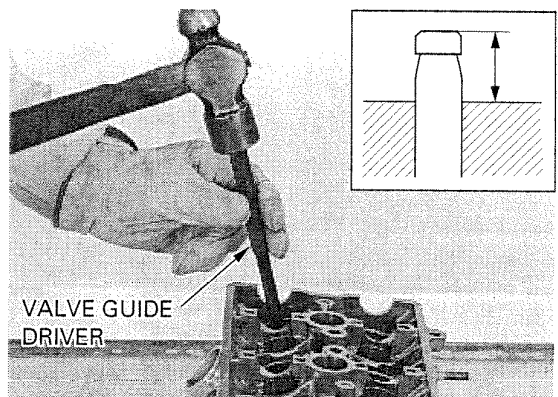

Ream the new valve guides.
Insert the reamer from the combustion chamber side of the head and always rotate the reamer clockwise.

TOOL:
Valve guide reamer, 4.008 mm 07MMH-MV90100

- NOTE:**
- Take care not to tilt or lean the reamer in the guide while reaming.
 - Use cutting oil on the reamer during this operation.

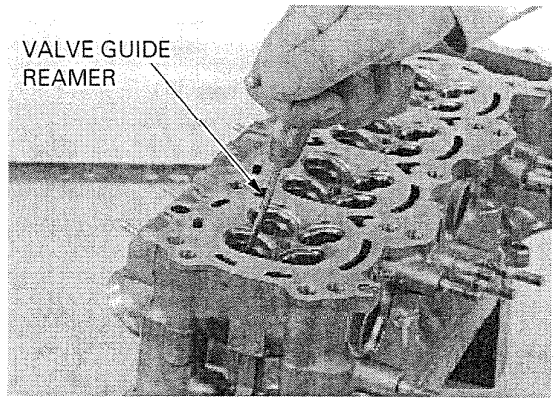

Clean the cylinder head thoroughly to remove any metal particles after reaming and reface the valve seat (page 8-14).

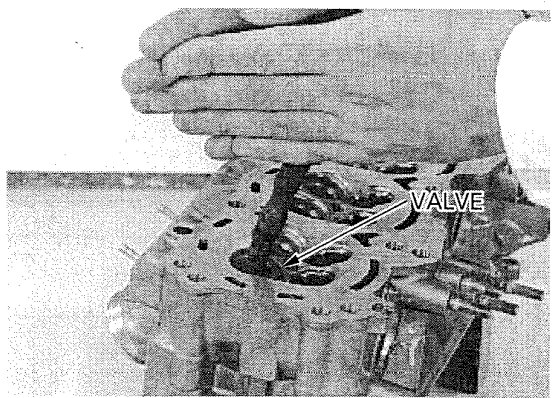

VALVE SEAT INSPECTION/REFACING

INSPECTION

Clean all intake and exhaust valves thoroughly to remove carbon deposits.

Apply a light coating of Prussian Blue to each valve seat.

Tap the valve against the valve seat several times without rotating the valve, to check for proper valve seat contact.

Remove the valve and inspect the valve seat face. The valve seat contact should be within the specified width and even all around the circumference.

STANDARD :
IN/EX: 0.90–1.10 mm (0.035–0.043 in)
SERVICE LIMIT: IN/EX: 1.5 mm (0.06 in)

If the valve seat width is not within specification, reface the valve seat (page 8-14)

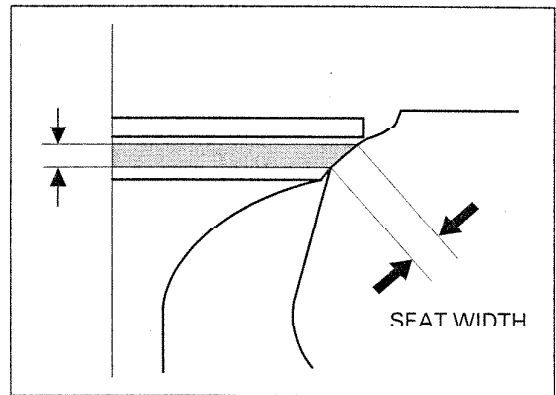

- Inspect the valve seat face for:
- Uneven seat width:
 - Replace the valve and reface the valve seat.
 - Damaged face:
 - Replace the valve and reface the valve seat.

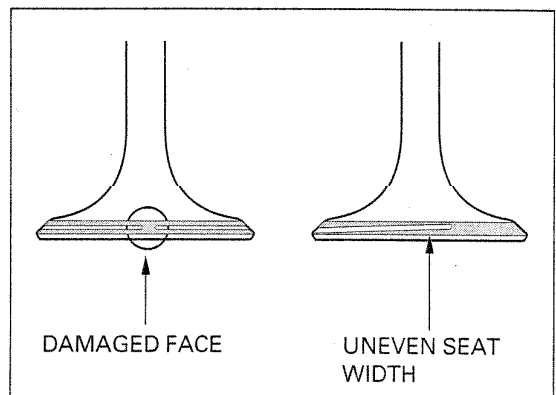

CYLINDER HEAD/VALVE

- Contact area (too high or too low)
- Reface the valve seat.

NOTE:

The valve cannot be ground. If the valve face is burned or badly worn or if it contacts the seat unevenly, replace the valve.

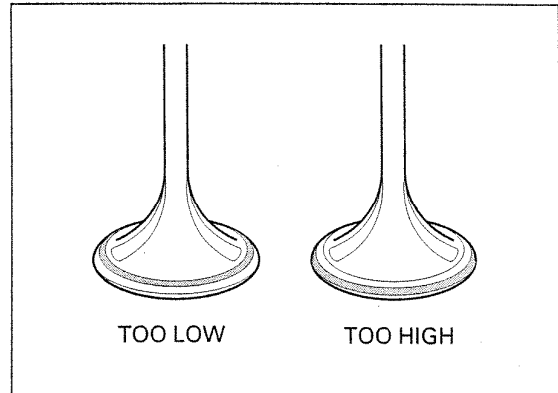

REFACING

NOTE:

- Follow the refacing manufacturer's operating instructions.
- Be careful not to grind the seat more than necessary.

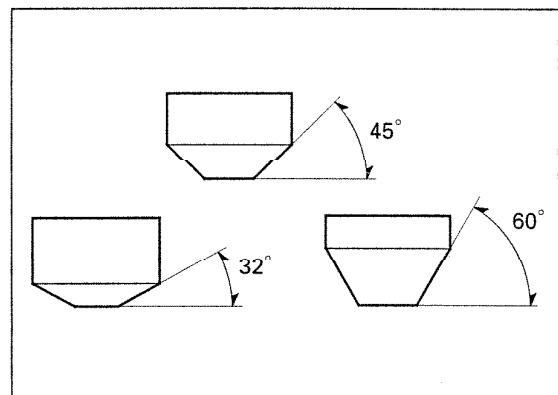

If the contact area is too high on the valve, the seat must be lowered using a 32° flat cutter.

If the contact area is too low on the valve, the seat must be raised using a 60° interior cutter.

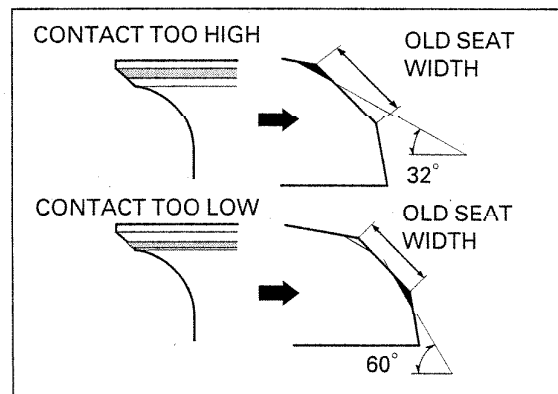

Using a 45° seat cutter, remove any roughness or irregularities from the seat.

TOOLS:

- Seat cutter, 27.5 mm 07780-0010200
- Seat cutter, 24.5 mm 07780-0010100
- Cutter holder, 4.0 mm 07781-0010500 or equivalent commercially available in U.S.A.

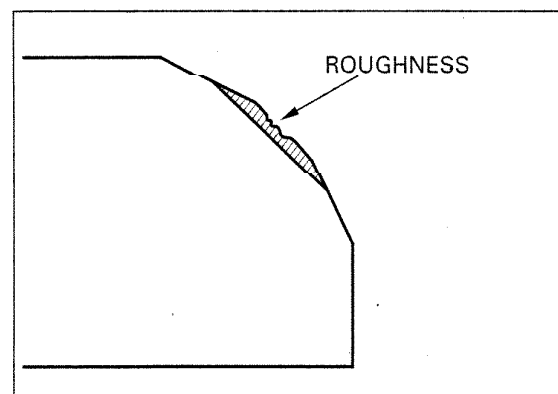

CYLINDER HEAD/VALVE

Using a 32° flat cutter, remove 1/4 of the existing valve seat material.

TOOLS:

Flat cutter, 27 mm (IN) 07780-0013300
Flat cutter, 24 mm (EX) 07780-0012500
Cutter holder, 4.0 mm 07781-0010500 or
equivalent commercially
available in U.S.A.

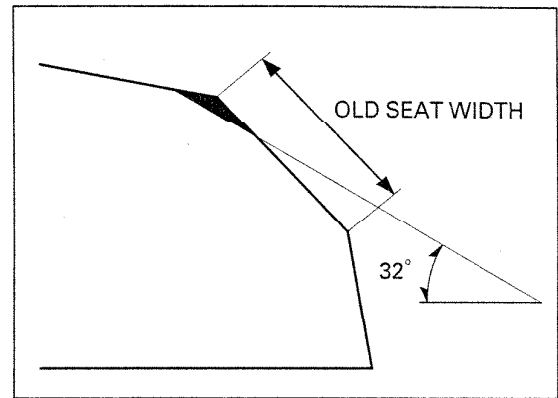

Using a 60° interior cutter, remove 1/4 of the existing valve seat material.

TOOLS:

Interior cutter, 26 mm 07780-0014500
Interior cutter, 22 mm 07780-0014202
Cutter holder, 4.0 mm 07781-0010500 or
equivalent commercially
available in U.S.A.

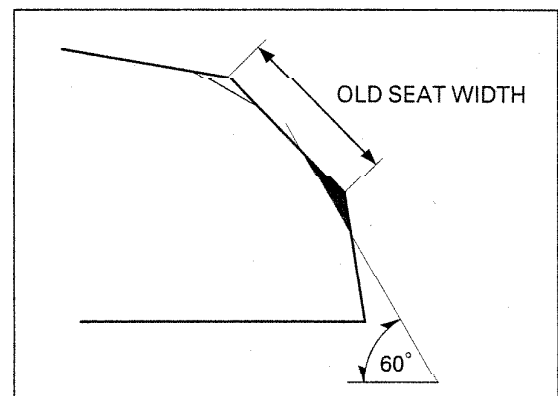

Using a 45° seat cutter, cut the seat to the proper width.

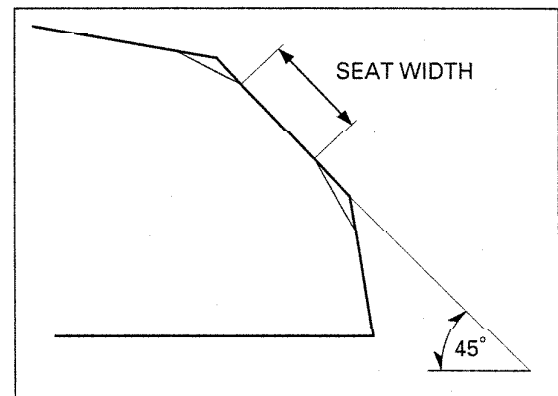

After cutting the seat, apply lapping compound to the valve face, and lap the valve using light pressure.

CAUTION:

- Excessive lapping pressure may deform or damage the seat.
- Change the angle of lapping tool frequently to prevent uneven seat wear.
- Do not allow lapping compound to enter the guides.

After lapping, wash any residual compound off the cylinder head and valve and recheck the seat contact.

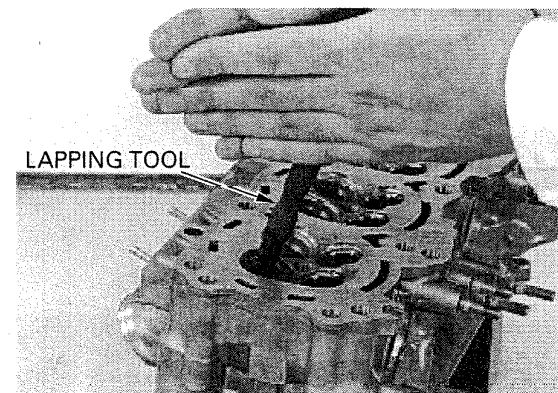

CYLINDER HEAD/VALVE

CYLINDER HEAD ASSEMBLY

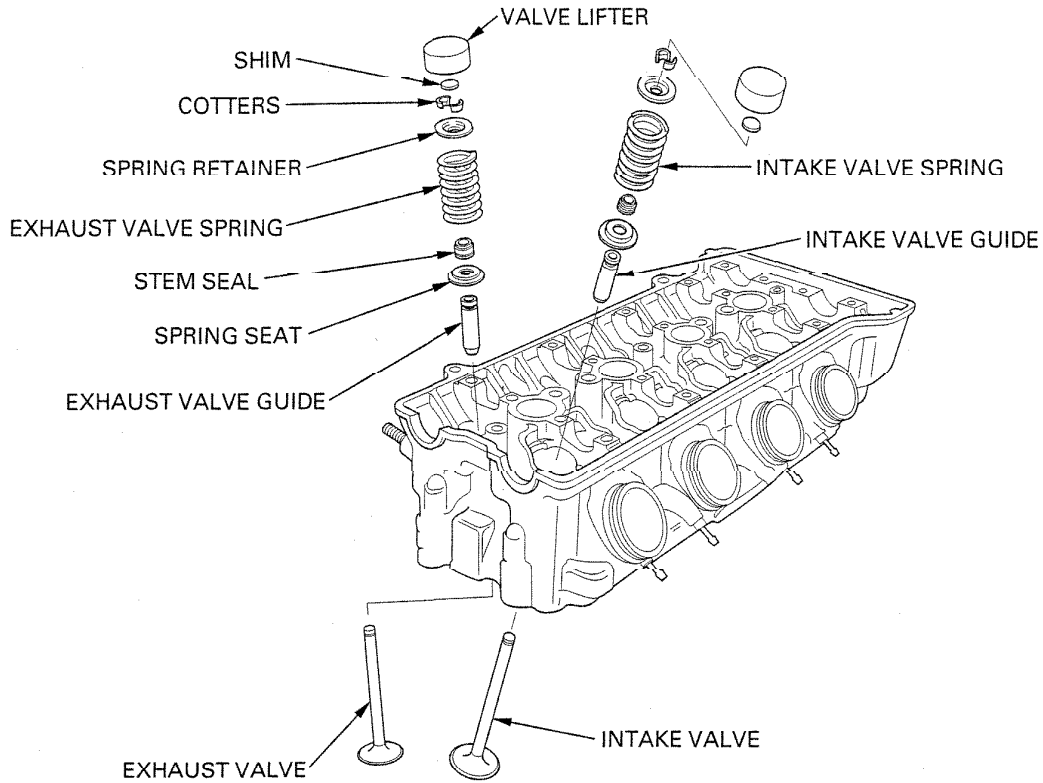

Blow through all oil passages in the cylinder head with compressed air.
Install the spring seats and new stem seals.

Lubricate the valve stem sliding surface with molybdenum oil solution.
Insert the valve into the guide while turning it slowly to avoid damage to the stem seal.

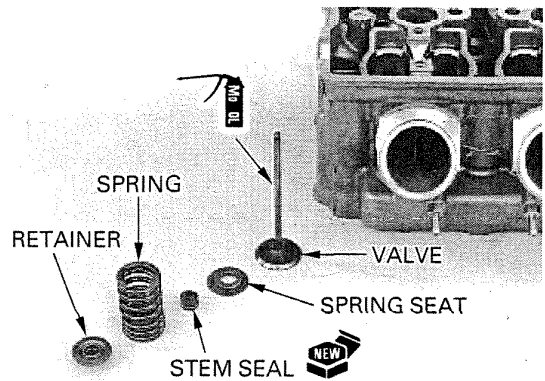

Install the valve spring with the tightly wound coils facing the combustion chamber.

Install the spring retainer.

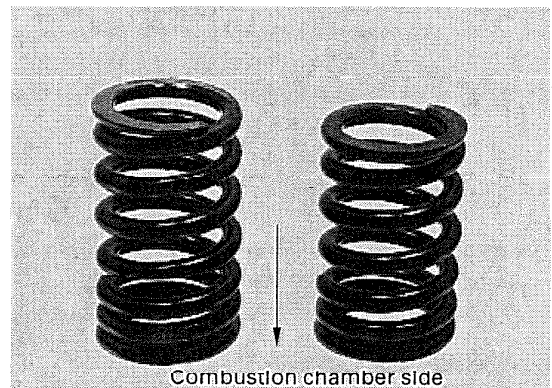

CYLINDER HEAD/VALVE

Install the tappet hole protector into the valve lifter bore.

TOOL:
Tappet hole protector 07HMG-MR70002

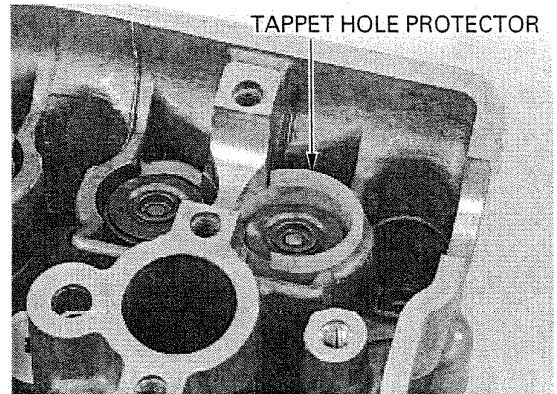

Grease the cotters to ease installation. Install the valve spring cotters using the valve spring compressor.

TOOLS:
Valve spring compressor 07757-0010000
Compressor attachment 07959-KM30101

CAUTION:

To prevent loss of tension, do not compress the valve springs more than necessary to install the cotters.

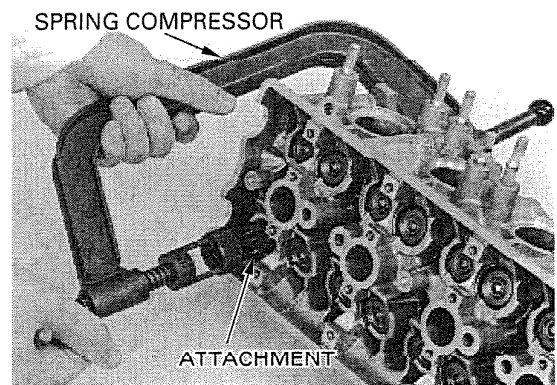

Support the cylinder head so that the valve heads will not contact anything that cause damage. Tap the valve stems gently with two plastic hammers as shown to seat the cotters firmly.

Install and tighten the spark plugs.

TORQUE : 12 N·m (1.2 kgf·m , 9 lbf·ft)

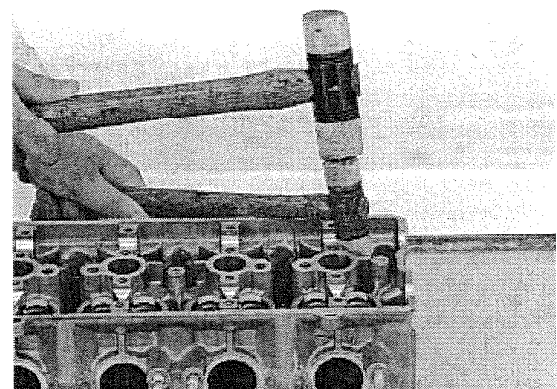

CYLINDER HEAD INSTALLATION

Install the dowel pins and a new gasket.



CYLINDER HEAD/VALVE

Install the cylinder head onto the cylinder.

Apply molybdenum oil solution to the threads and seating surfaces of the 9 mm cylinder head bolts and install them.

Tighten the 9 mm bolts in a crisscross pattern in 2 or 3 steps.

TORQUE : 47 N·m (4.8 kgf·m , 35 lbf·ft)

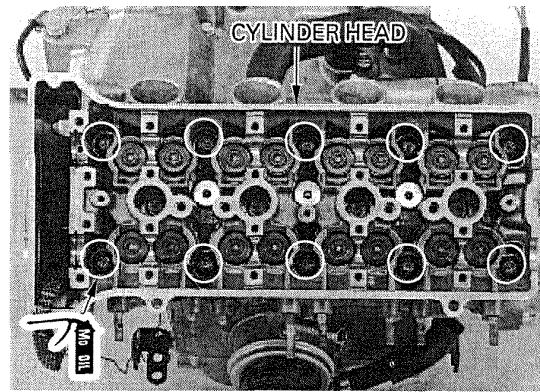

Install and tighten the two 6 mm bolts.

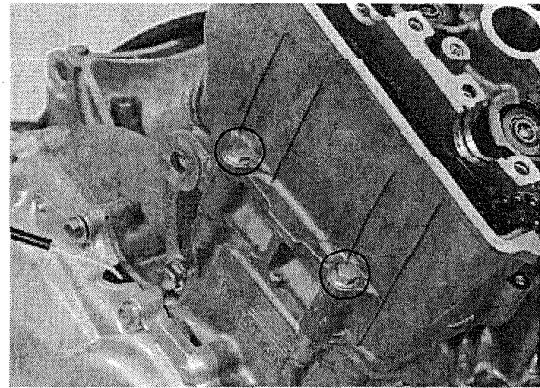

If the engine is out of the frame, do not install the thermostat yet. Install a new O-ring into the thermostat housing groove. Install thermostat housing onto the cylinder head and tighten the two bolts.

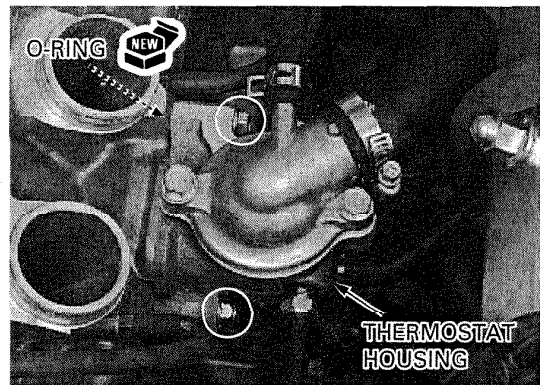

Turn the cam chain tensioner lifter shaft clockwise fully to retract the tensioner lifter and secure it with a stopper tool.

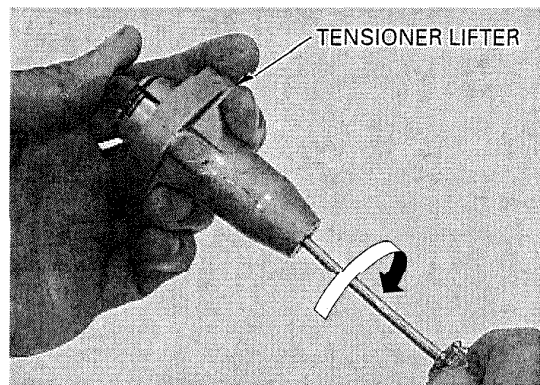

Install a new gasket onto the tensioner lifter.
 Install the tensioner lifter onto the cylinder head and tighten the two bolts with new sealing washers.

TORQUE : 10 N·m (1.0 kgf·m , 7 lbf·ft)

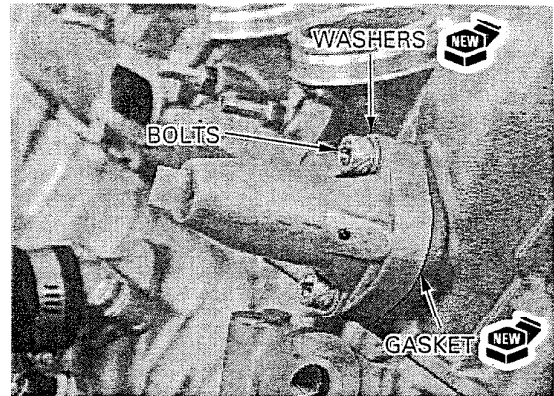

CAMSHAFT INSTALLATION

CAUTION:

Do not get molybdenum oil solution to the camshaft holder mating surfaces and holder bolt holes. It may fail to tighten the camshaft holder bolts for correct torque value.

Install the valve shims in their original locations.

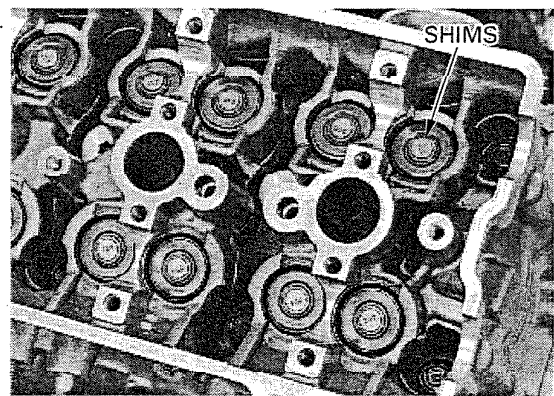

Coat the outer surfaces of the valve lifters with molybdenum oil solution.
 Install the valve lifters in their original lifter bores, being careful not to damage the sliding surfaces of the lifters and bores.

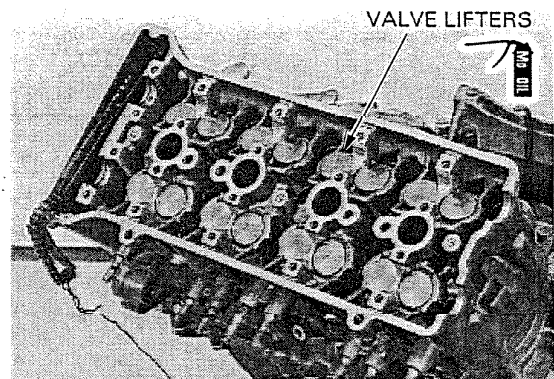

Apply molybdenum oil solution to the camshaft journals and cam lobes.

The camshafts have the identification mark:

- IN: intake
- EX: exhaust

Install the camshafts onto the cylinder head with both No. 1 cam lobes facing up diagonally as shown.

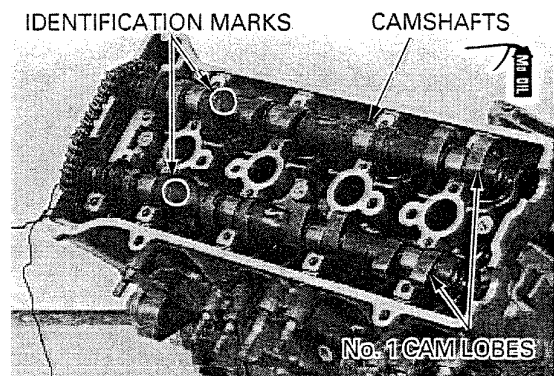

CYLINDER HEAD/VALVE

Coat new O-rings with oil and install them into the grooves in the camshaft holder.

Loosely install the camshaft holder.

Apply engine oil to the threads and seating surfaces of the camshaft holder bolts. Install the twenty bolts with eight new washers as shown. Finger tighten the bolts.

Be sure the dowel pins in the camshaft holder align properly with the holes in the cylinder head.

The camshaft holder has the numbers "1 through 20" cast into it. Gradually tighten the the #6, #5, #8, #7, #2 and #1 bolts (in that order) 1/2 turn at a time to draw the holder down evenly until the clearance between the cylinder head and the holder is 2-3mm all the way around.

If the holder tilts toward the #1 cylinder during this process, readjust bolts #6, #5, #8, #7, #2 and #1 as necessary to keep the holder level. When the holder is parallel with the cylinder head, resume tightening the bolts in the sequence specified above.

Once the clearance is within 2-3mm, begin tightening all the bolts in numerical order (#1, #2, #3...#20) 1/4 to 1/2 turn at a time until the holder is fully seated against the cylinder head.

TORQUE : 12 N·m (1.2 kgf·m , 9 lbf·ft)

Be careful not to jam the cam chain at the crankshaft when turning the crankshaft.

Turn the crankshaft clockwise and align "T" mark on the ignition pulse generator rotor with the index notch on the right crankcase cover

Install the cam sprockets onto the cam chain and cam sprocket flanges so that the timing marks ("IN" for intake and "EX" for exhaust) on the sprockets are flush with the cylinder head surface and facing outward as shown.

Make sure that both No. 1 cam lobes are facing up diagonally, align the bolt holes in the cam sprockets and camshafts.

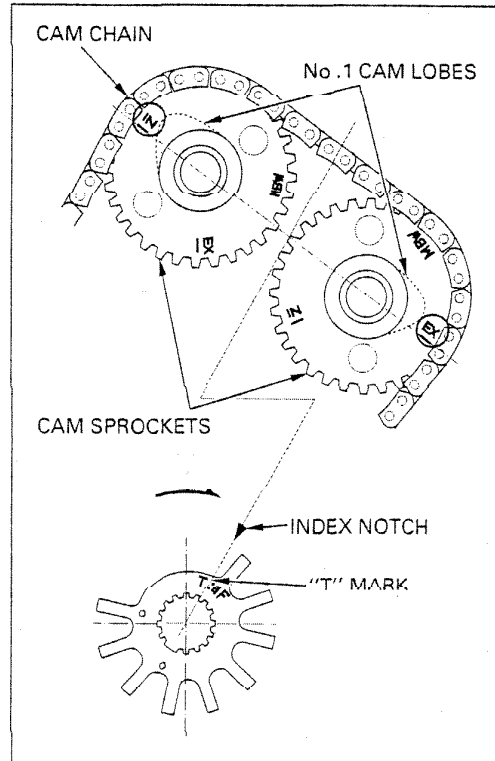
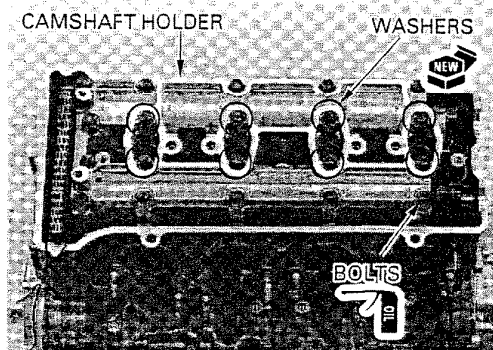
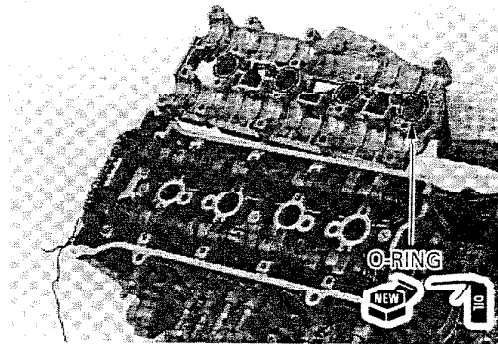

Apply locking agent to the cam sprocket bolt threads.

Install the cam sprocket bolts.

Turn the crankshaft clockwise one turn and install the remaining cam sprocket bolts.
Tighten the cam sprocket bolts.

TORQUE : 20 N·m (2.0 kgf·m , 14 lbf·ft)

Turn the crankshaft clockwise one turn and tighten the other sprocket bolts to the same torque.

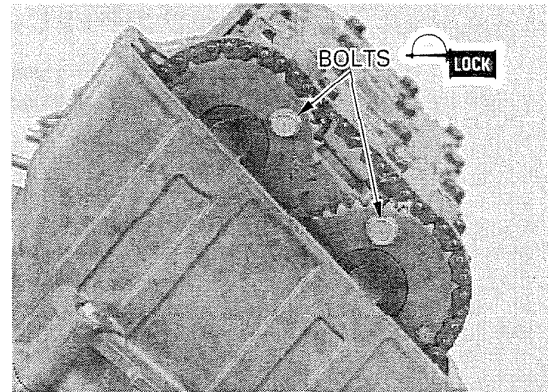

Install the cam chain guide plate and tighten the two bolts.

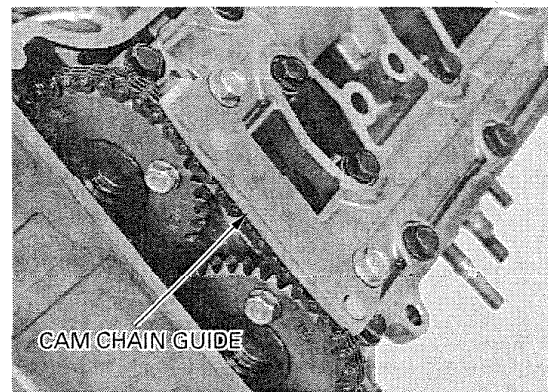

Remove the stopper tool from the cam chain tensioner lifter and install the sealing bolt with a new sealing washer.

Install the timing hole cap (page 3-11)

Install the cylinder head cover.

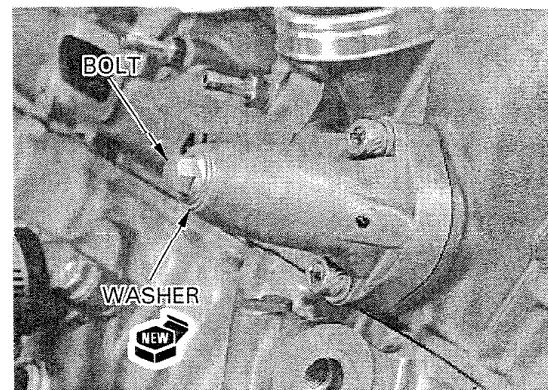

CYLINDER HEAD COVER INSTALLATION

Install a new gasket in the head cover groove.

Apply sealant to the cylinder head semi-circular areas.

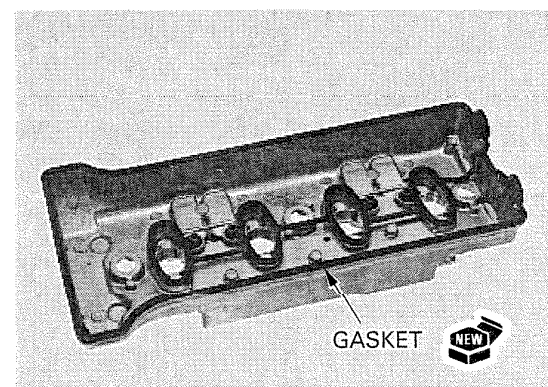

CYLINDER HEAD/VALVE

Install the head cover onto the cylinder head.

Install the special washers onto the head cover bolts with the "UP" mark facing the bolt head.

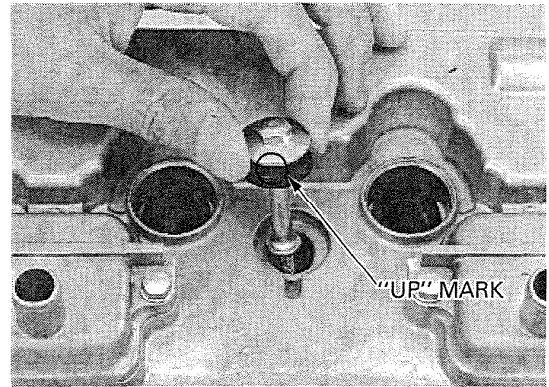

Install the three head cover bolts by aligning them with the bolt hole in the cylinder head properly. Tighten the bolts in 2 or 3 steps.

TORQUE : 10 N·m (1.0 kgf·m , 7 lbf·ft)

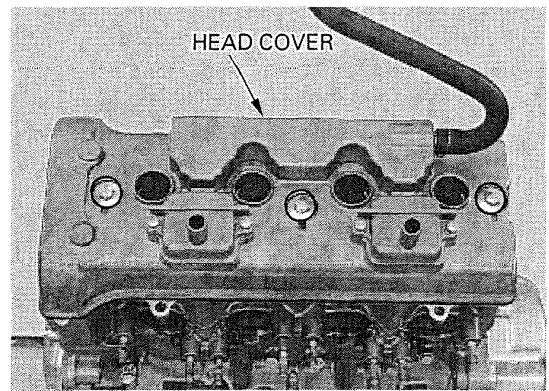

Connect the air supply hoses and the vacuum tube to install the PAIR control valve.

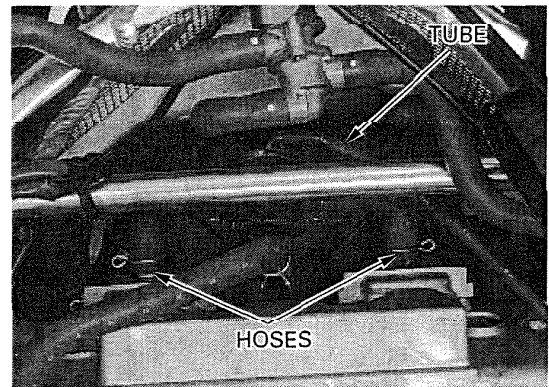

The cylinder numbers are printed on each ignition coil wire. Install the direct ignition coils onto the spark plugs. Connect each 2P connector to the correct ignition coil. Install the carburetor (page 5-30). Fill and bleed the cooling system if the cylinder head was removed (page 6-4).

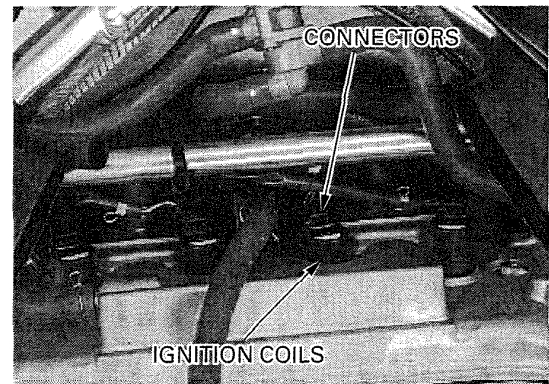

MEMO

CLUTCH/GEARSHIFT LINKAGE

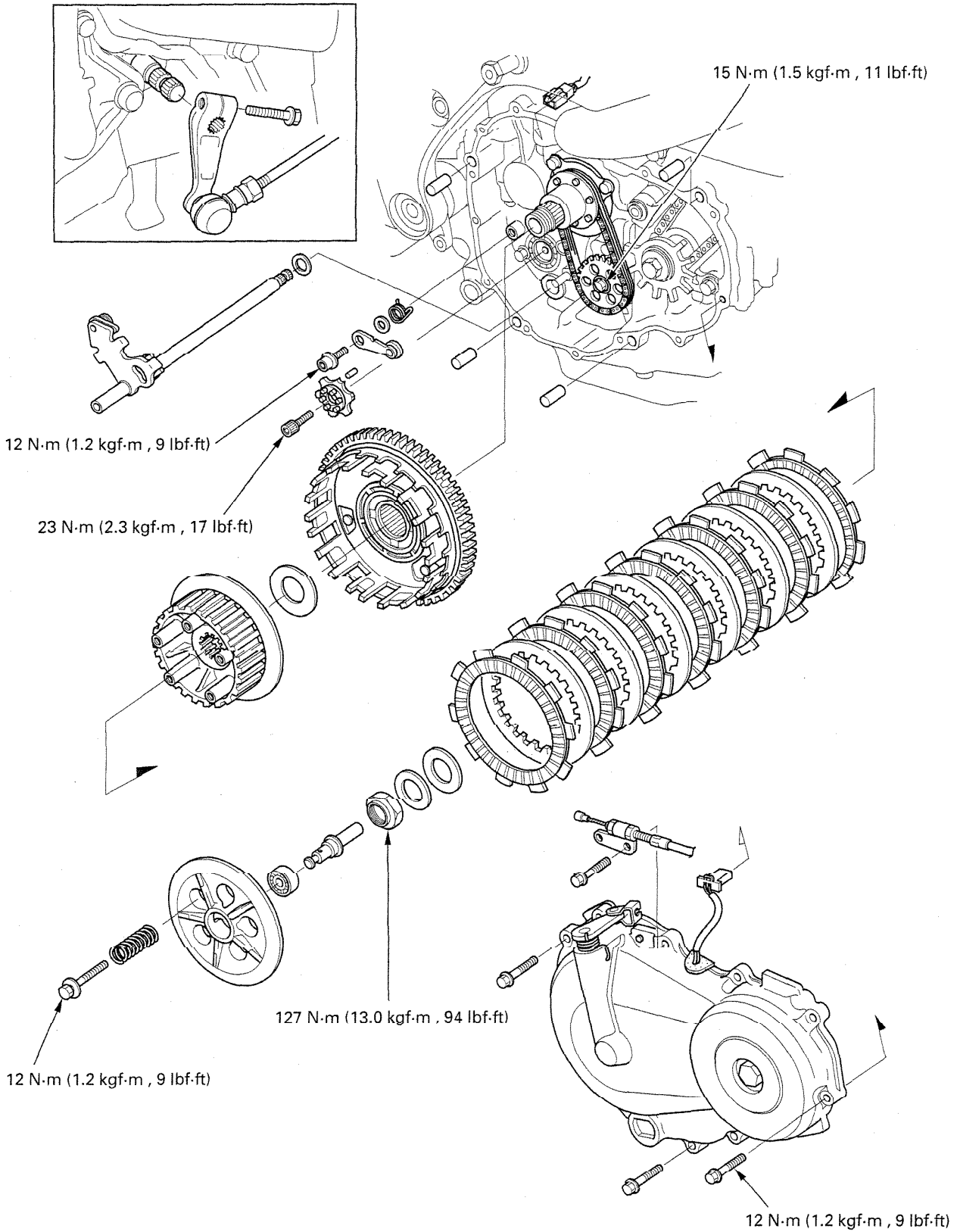

9. CLUTCH/GEARSHIFT LINKAGE

SERVICE INFORMATION	9-1	GEARSHIFT LINKAGE	9-12
TROUBLESHOOTING	9-2	RIGHT CRANKCASE COVER INSTALLATION	9-14
RIGHT CRANKCASE COVER REMOVAL	9-3		
CLUTCH	9-4		

SERVICE INFORMATION

GENERAL

- The clutch and gearshift linkage can be serviced with the engine installed in the frame.
- Engine oil viscosity and level and the use of oil additives have an effect on clutch disengagement. Oil additives of any kind are specifically not recommended. When the clutch does not disengage or the motorcycle creeps with the clutch disengaged, inspect the engine oil and oil level before servicing the clutch system.
- The crankcase must be separated when the transmission, shift drum and shift forks require service (section 11).

SPECIFICATIONS

Unit: mm (in)

9

ITEM		STANDARD	SERVICE LIMIT
Clutch lever free play		10 – 20 (3/8 – 13/16)	
Clutch	Spring free length	46.5 (1.83)	45.2 (1.78)
	Disc thickness	2.92 – 3.08 (0.115 – 0.121)	2.6 (0.10)
	Plate warpage		0.30 (0.012)
Clutch outer guide	I.D.	25.000 – 25.021 (0.9843 – 0.9851)	25.03 (0.985)
	O.D.	34.975 – 34.991 (1.3770 – 1.3776)	34.97 (1.377)
Mainshaft O.D. at clutch outer guide		24.980 – 24.993 (0.9835 – 0.9840)	24.96 (0.983)

TORQUE VALUES

Clutch center lock nut	127 N·m (13.0 kgf·m , 94 lbf·ft)	Apply oil to the threads and seating surface and stake
Clutch bolt	12 N·m (1.2 kgf·m , 9 lbf·ft)	
Oil pump driven sprocket bolt	15 N·m (1.5 kgf·m , 11 lbf·ft)	Apply locking agent to the threads
Gearshift cam bolt	23 N·m (2.3 kgf·m , 17 lbf·ft)	Apply locking agent to the threads
Gearshift stopper arm bolt	12 N·m (1.2 kgf·m , 9 lbf·ft)	
Right crankcase cover bolt	12 N·m (1.2 kgf·m , 9 lbf·ft)	page 9-15

TOOLS

Clutch center holder	07724-0050002 or equivalent commercially available in U.S.A.
Driver	07749-0010000
Attachment, 32 × 35 mm	07746-0010100
Attachment, 37 × 40 mm	07746-0010200
Attachment, 42 × 47 mm	07746-0010300
Pilot, 17 mm	07746-0040400
Pilot, 35 mm	07746-0040800

CLUTCH/GEARSHIFT LINKAGE

TROUBLESHOOTING

Clutch lever too hard

- Damaged, kinked or dirty clutch cable
- Improperly routed clutch cable
- Damaged clutch lifter mechanism
- Faulty clutch lifter bearing

Clutch will not disengage or motorcycle creeps with clutch disengaged

- Too much clutch lever free play
- Warped clutch plates
- Loose clutch lock nut
- Engine oil level too high, improper oil viscosity or oil additive used

Clutch slips

- No clutch lever free play
- Worn clutch discs
- Weak clutch springs
- Clutch lifter sticking
- Engine oil level too low or oil additive used

Hard to shift

- Improper clutch operation
- Incorrect engine oil viscosity
- Incorrect clutch adjustment
- Bent or damaged gearshift spindle
- Damaged gearshift cam
- Bent fork shaft or damaged shift forks and shift drum (section 11)

Transmission jumps out of gear

- Broken shift drum stopper arm
- Weak or broken shift linkage return springs
- Worn or damaged gearshift cam
- Bent fork shaft or worn shift forks and shift drum (section 11)
- Worn gear dogs or slots (section 11)

RIGHT CRANKCASE COVER REMOVAL

Drain the engine oil (page 3-12).
Remove the right side fairing (page 2-4).
Raise the fuel tank and support it (page 2-3).

Remove the cable holder bolt and clutch cable holder, and disconnect the clutch cable from the clutch lifter arm.

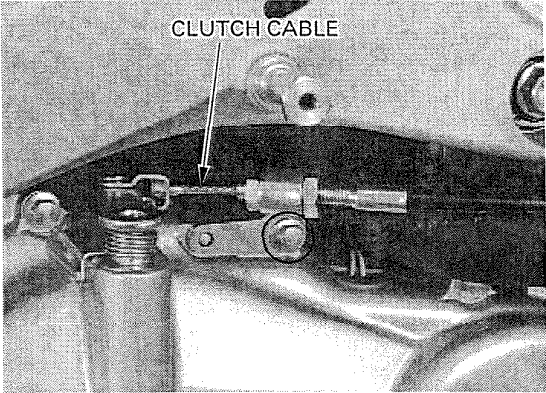

Disconnect the ignition pulse generator 2P connector.

Remove the crankcase cover bolts.

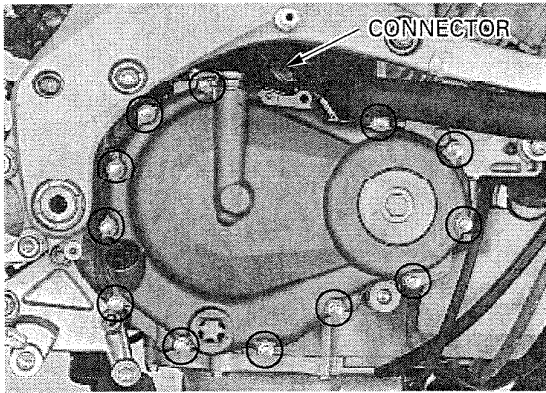

The lifter arm spindle is engaged with the clutch lifter piece inside the right crankcase cover.

Remove the crankcase cover while turning the clutch lifter arm counterclockwise to disengage the lifter arm spindle from the lifter piece.

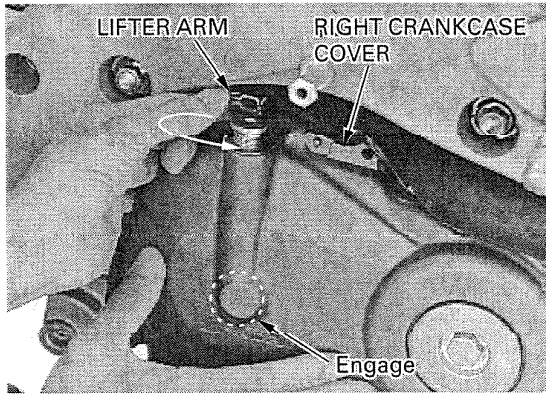

Remove the four dowel pins.

Clean any sealant from the crankcase cover mating surfaces.

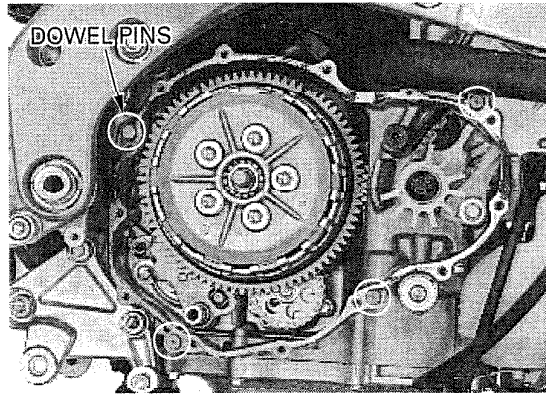

CLUTCH/GEARSHIFT LINKAGE

CLUTCH LIFTER ARM

Remove the clutch lifter arm, return spring and washer from the right crankcase cover.

Check the lifter arm spindle for wear or damage.
Check the return spring for fatigue or damage.

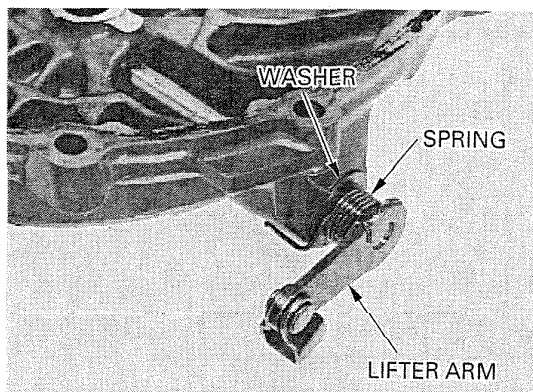

Check the lifter arm oil seal and needle bearings for wear or damage.

Install the clutch lifter arm with the spring and washer as shown.

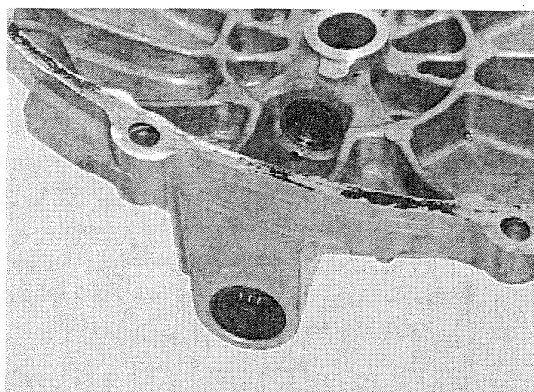

CLUTCH

DISASSEMBLY

Remove the right crankcase cover (page 9 3).

Remove the clutch bolts, springs and pressure plate.
Remove the clutch lifter piece.

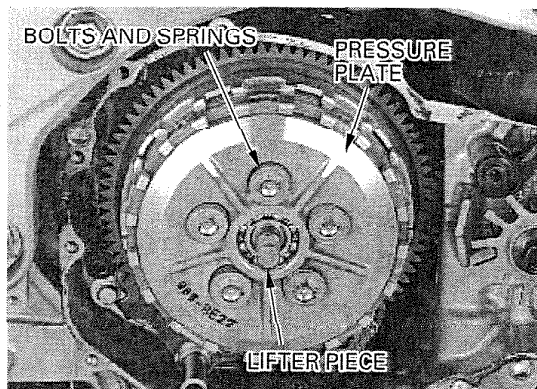

Remove the seven clutch discs and six plates.

NOTE

The two discs (B) on both ends are different from the five discs (A). Do not confuse the discs A and B.

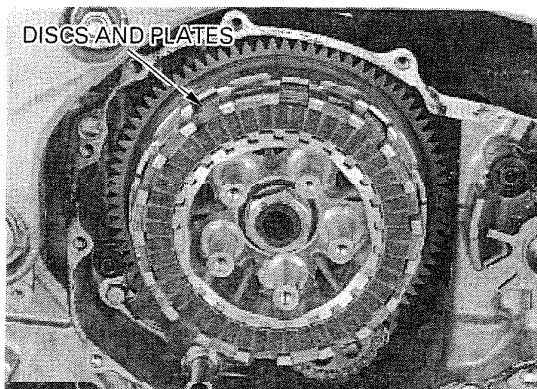

CLUTCH/GEARSHIFT LINKAGE

Be careful not to damage the mainshaft threads.
Unstake the clutch center lock nut.

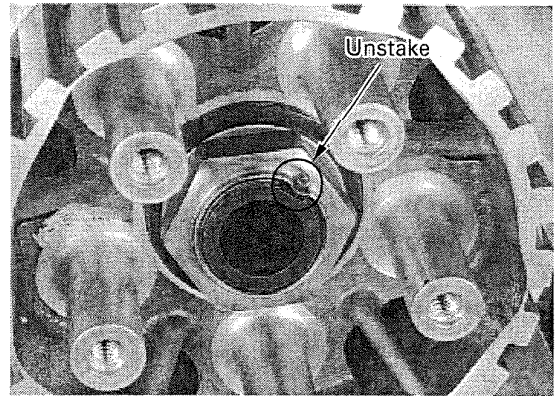

Hold the clutch center with the special tool and remove the clutch center lock nut.

TOOL:
Clutch center holder 07724-0050002 or equivalent commercially available in U.S.A.

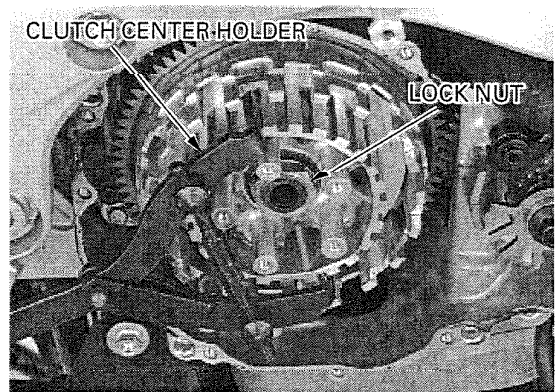

Remove the special washer, plain washer and clutch center.

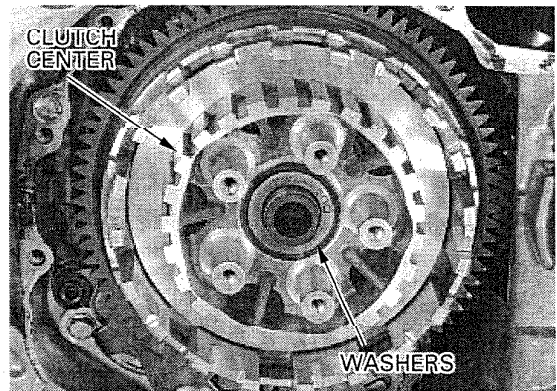

Remove the thrust washer.

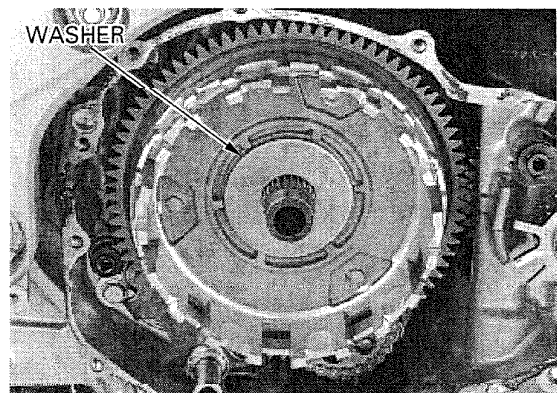

CLUTCH/GEARSHIFT LINKAGE

Be careful not to bend the ignition pulse generator rotor tangs.

Raise the fuel tank and support it (page 2-3).
Loosen the cam chain tensioner (page 8-4).
Align the gear teeth of the scissors gears (primary drive gear and sub-gear) by inserting a 5 mm steel pin or screwdriver at least 61 mm in length into the gear hole through the hole in the crankcase, and remove the clutch outer.
The ignition pulse generator rotor must be aligned as shown.

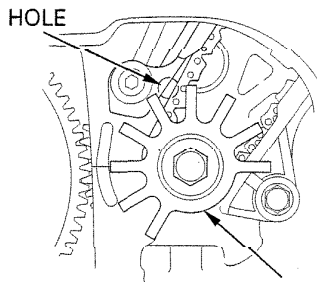

Remove the oil pump driven sprocket bolt and washer.
Remove the oil pump driven sprocket, drive chain and drive sprocket as a set.
Remove the clutch outer guide.

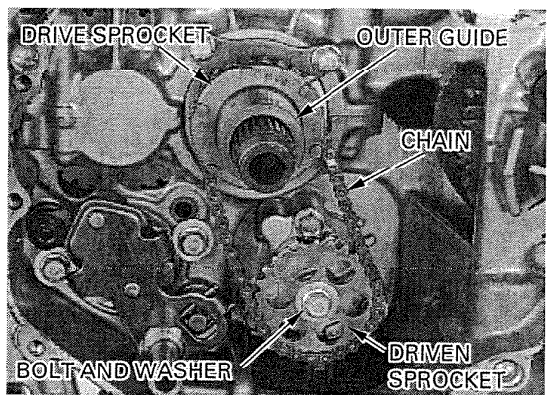
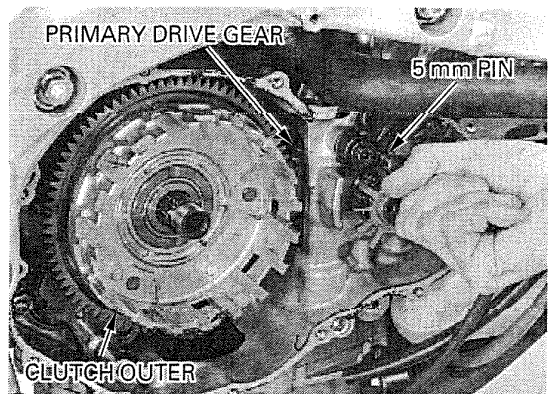

INSPECTION

LIFTER BEARING

Turn the inner race of the lifter bearing with your finger.
The bearing should turn smoothly and quietly.
Also check that the outer race of the bearing fits tightly in the pressure plate.
Replace the bearing if the inner race does not turn smoothly, quietly, or if the outer race fit loosely in the pressure plate.

Drive the bearing out of the pressure plate.

Drive a new bearing into the plate with its mark side facing out.

TOOLS:

Driver	07749-0010000
Attachment, 32 × 35 mm	07746-0010100
Pilot, 17 mm	07746-0040400

CLUTCH SPRING

Replace the clutch springs as a set. Measure the clutch spring free length.

SERVICE LIMIT: 45.2 mm (1.78 in)

LIFTER BEARING

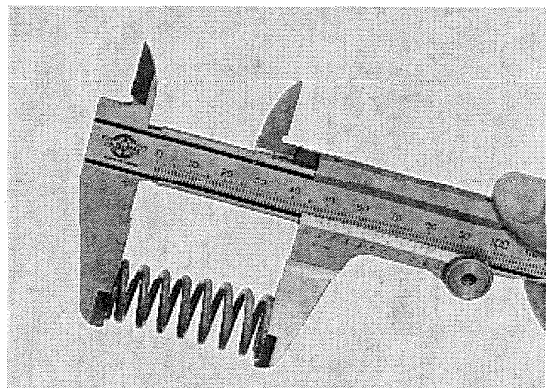
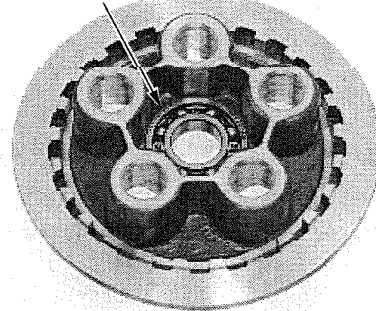

CLUTCH CENTER

Check the clutch center and pressure plate for nicks, indentations or abnormal wear made by the plates.

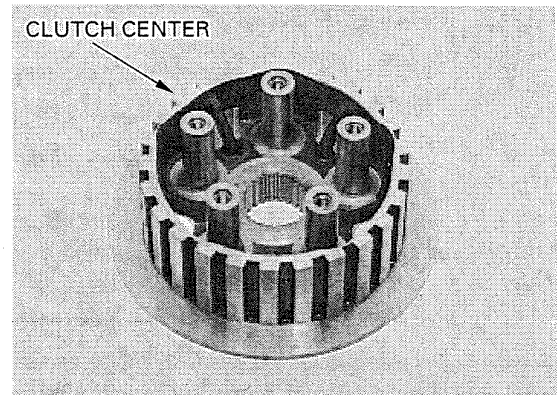

CLUTCH LIFTER PIECE

Check the lifter piece for damage or abnormal wear.

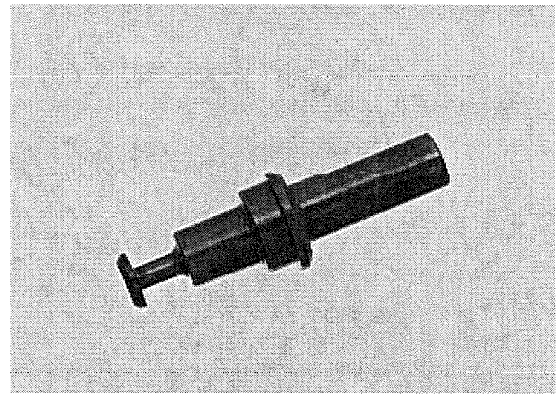

CLUTCH DISC

Replace the clutch discs and plates as a set.

Check the clutch discs for signs of scoring or discoloration. Measure the clutch disc thickness.

SERVICE LIMIT: 2.6 mm (0.10 in)

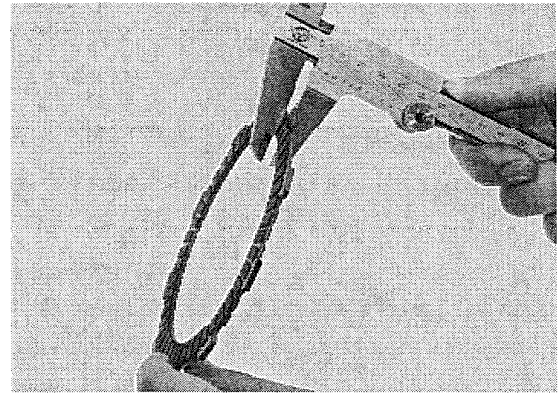

CLUTCH PLATE

Replace the clutch discs and plates as a set.

Check the plates for discoloration. Check the plate warpage on a surface plate using a feeler gauge.

SERVICE LIMIT: 0.30 mm (0.012 in)

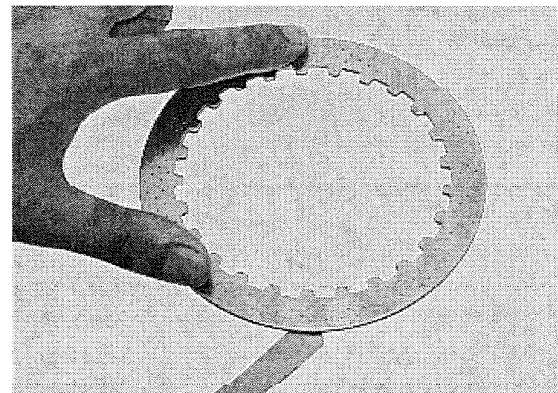

CLUTCH/GEARSHIFT LINKAGE

CLUTCH OUTER GUIDE

Measure the clutch outer guide I.D. and O.D.

SERVICE LIMITS: I.D.: 25.03 mm (0.985 in)
O.D.: 34.97 mm (1.377 in)

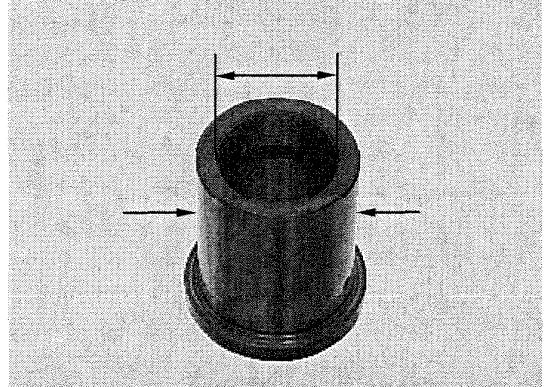

MAINSHAFT

Measure the mainshaft O.D. at the clutch outer guide.

SERVICE LIMIT: 24.96 mm (0.983 in)

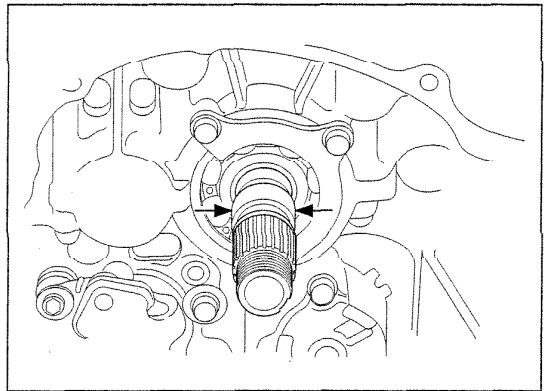

CLUTCH OUTER

Check the slots in the clutch outer for nicks, indentation or abnormal wear made by the clutch discs.

Check the needle bearing for wear or damage.
Replace the bearing if necessary.

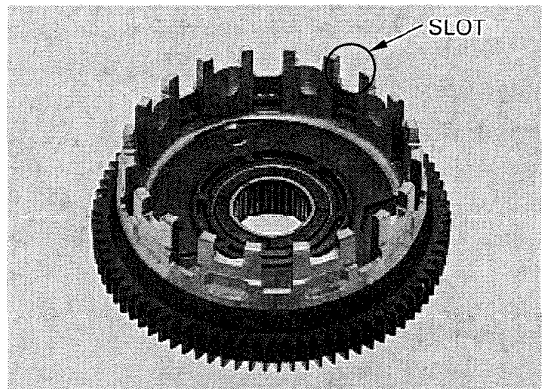

Press the needle bearing out of the clutch outer using the special tools.

TOOLS:

Driver	07749-0010000
Attachment, 37 × 40 mm	07746-0010200
Pilot, 35 mm	07746-0040800

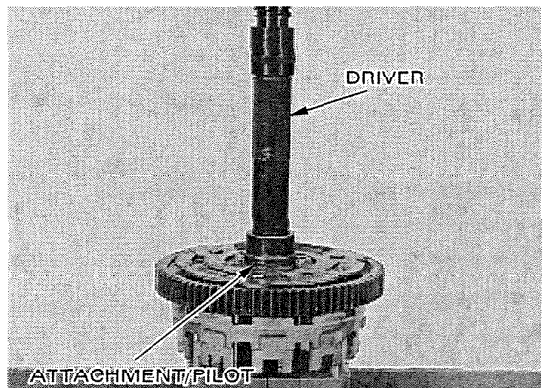

CLUTCH/GEARSHIFT LINKAGE

Using the special tools, press the needle bearing in the clutch outer until the depth below the raised portion of the clutch outer surface (oil pump drive sprocket side) is 0.4–0.6 mm.

TOOLS:

Driver 07749-0010000
Attachment, 42 × 47 mm 07746-0010300
Pilot, 35 mm 07746-0040800

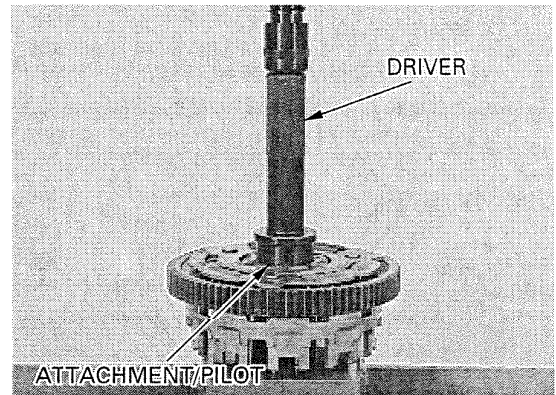

ASSEMBLY

If removed, install the gearshift linkage (page 9-13).

Coat the clutch outer guide with molybdenum oil solution and install it onto the mainshaft with the flange side facing the crankcase.

Install the oil pump drive sprocket (with the pins facing out), drive chain and driven sprocket as a set with the "OUT" mark on the driven sprocket facing out.

Apply locking agent to the oil pump driven sprocket bolt threads.
Install the bolt with the washer and tighten it..

TORQUE : 15 N·m (1.5 kgf·m , 11 lbf·ft)

Be careful not to bend the ignition pulse generator rotor tangs.

Align the gear teeth of the scissors gears (primary drive gear and sub-gear) by prying the gears with a screwdriver, then install the clutch outer.

Align the holes in the clutch outer with the pins on the oil pump drive sprocket by turning the oil pump driven sprocket while pushing in the clutch outer.

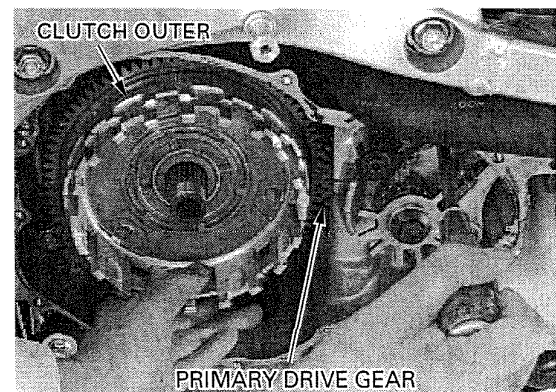
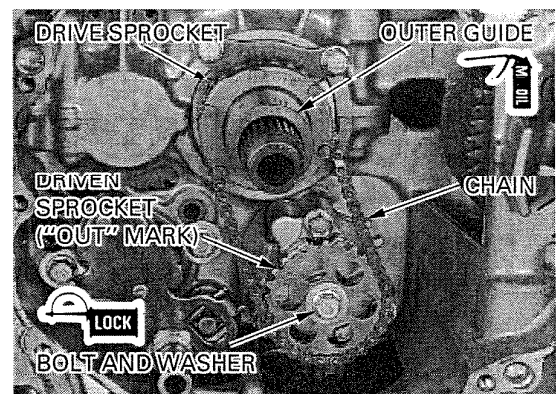

CLUTCH/GEARSHIFT LINKAGE

Make sure that the primary driven gear of the clutch outer is flush with the primary drive sub-gear.

Release the cam chain tensioner lifter (page 8-21).

Install the thrust washer.

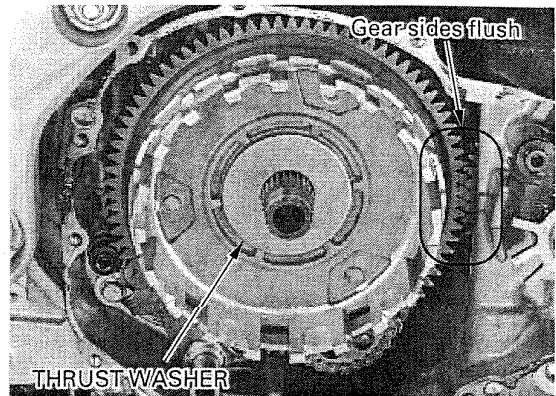

Install the clutch center.

Install the plain washer and special washer with the "OU1" mark on the special washer facing out.

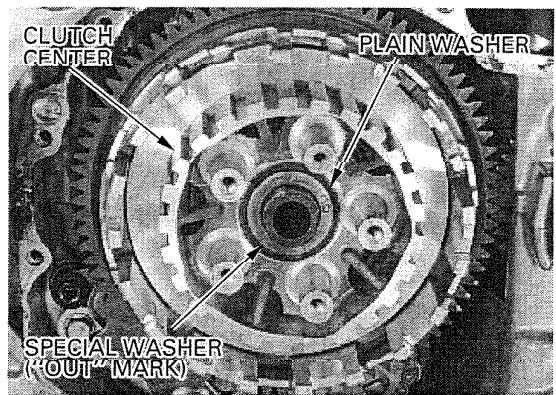

Apply engine oil to the threads and seating surface of a new clutch center lock nut and install it onto the mainshaft.

Hold the clutch center with the special tool and tighten the lock nut.

TOOL:

Clutch center holder 07724-0050002 or equivalent commercially available in U.S.A.

TORQUE : 127 N·m (13.0 kgf·m , 94 lbf·ft)

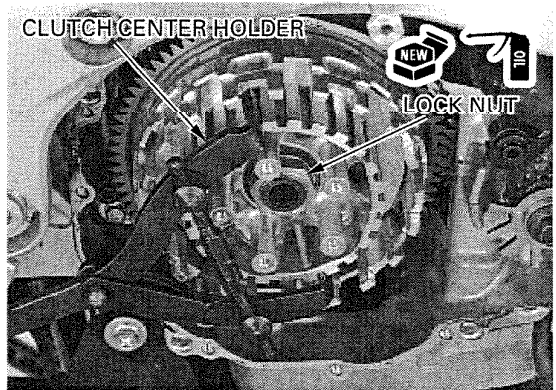

Be careful not to damage the mainshaft threads.

Stake the clutch center lock nut into the mainshaft groove.

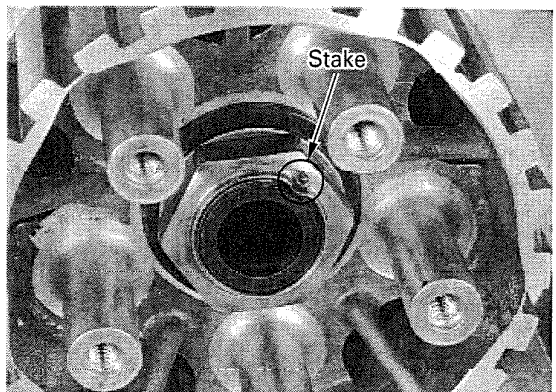

CLUTCH/GEARSHIFT LINKAGE

NOTE:

Do not confuse the clutch discs A and B.

Install the outside clutch disc (B) tabs into the shallow slots of the clutch outer.

Coat the clutch discs with clean engine oil. Install the seven clutch discs and six plates alternately, starting with the disc (B). (The two discs (B) are installed onto both ends.)

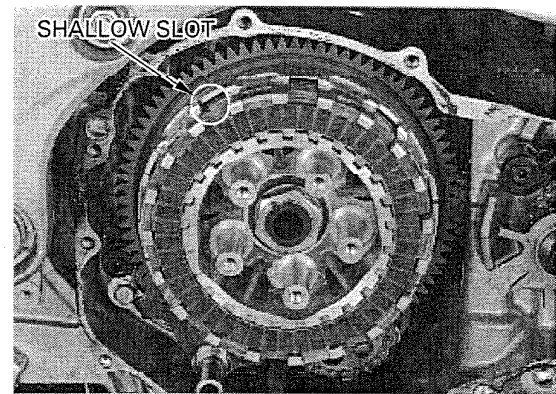
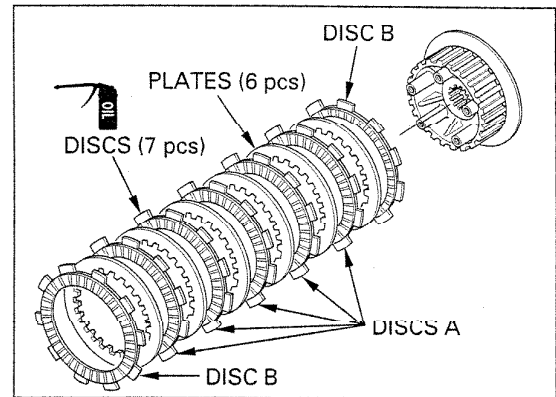

Install the clutch lifter piece into the lifter bearing. Install the pressure plate and the clutch bolts with the springs. Tighten the bolts in a crisscross pattern in 2 or 3 steps.

TORQUE : 12 N·m (1.2 kgf·m , 9 lbf·ft)

Install the right crankcase cover (page 9-14).

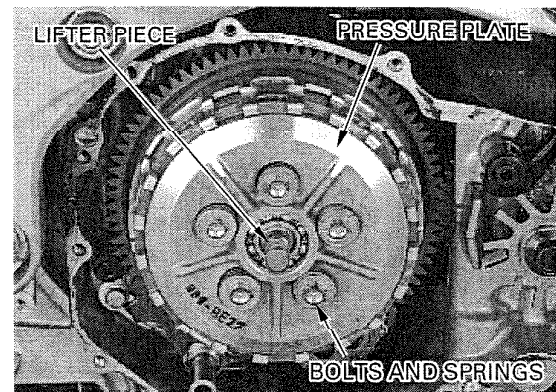

CLUTCH/GEARSHIFT LINKAGE

GEARSHIFT LINKAGE

REMOVAL

Disassemble the clutch to the clutch outer (page 9-4).

Remove pinch bolt and the gearshift arm.

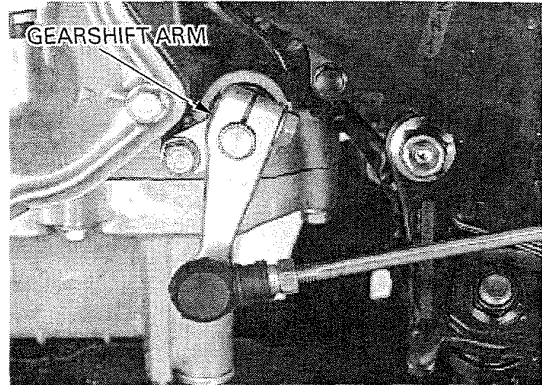

Remove the gearshift spindle assembly and thrust washer.

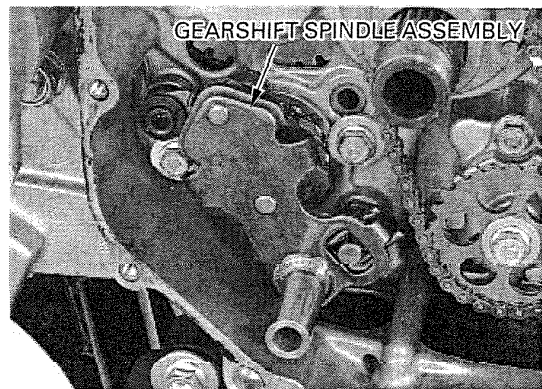

Remove the gearshift cam bolt and gearshift cam. Remove the dowel pin from the shift drum. Remove the stopper arm bolt, arm, washer and return spring.

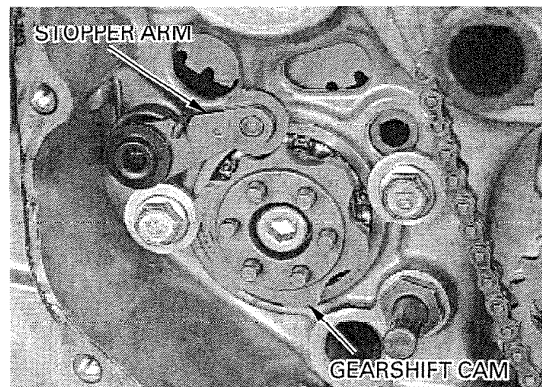

INSPECTION

Check the gearshift spindle for bending.
Check the spindle plate for wear or damage.
Check the spindle return spring for fatigue or damage.

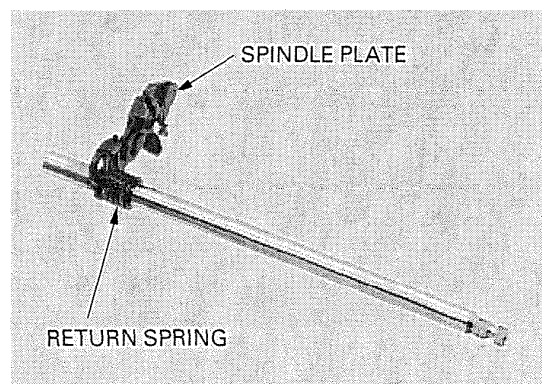

INSTALLATION

Install the return spring, washer (between the spring and arm), stopper arm and bolt, and tighten the bolt.

TORQUE : 12 N·m (1.2 kgf·m , 9 lbf·ft)

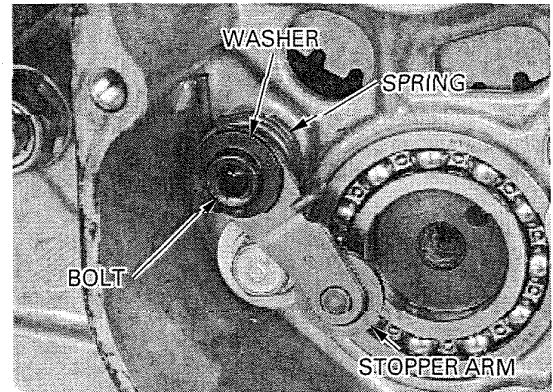

Install the dowel pin into the shift drum. Lift the stopper arm with a screwdriver and install the gearshift cam by aligning the pin hole in the cam with the dowel pin.

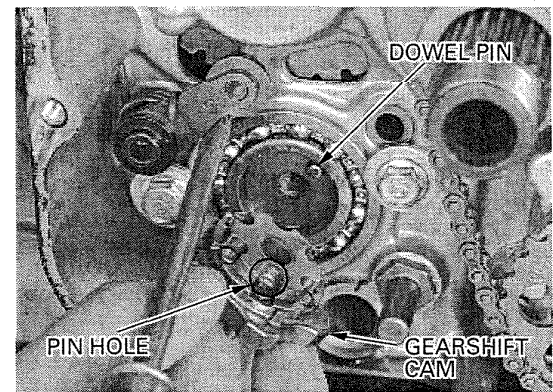

Apply locking agent to the gearshift cam bolt threads. Install and tighten the bolt.

TORQUE : 23 N·m (2.3 kaf·m . 17 lbf·ft)

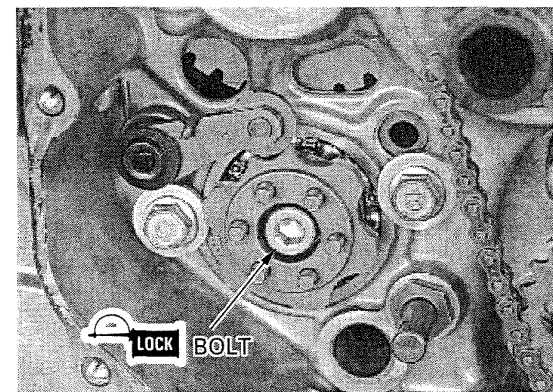

Install the thrust washer onto the gearshift spindle, and insert the spindle into the crankcase, aligning the return spring ends with the spring pin.

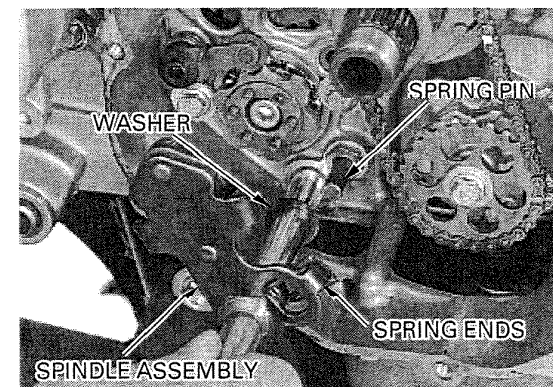

CLUTCH/GEARSHIFT LINKAGE

Install the gearshift arm onto the spindle, aligning the slit of the arm with the punch mark on the spindle.

Tighten the pinch bolt securely.

Assemble the clutch (page 9-9).

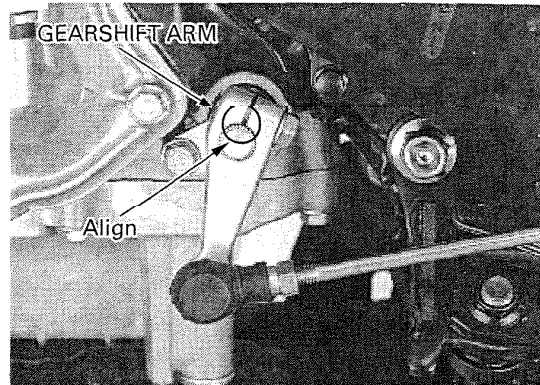

RIGHT CRANKCASE COVER INSTALLATION

Install the four dowel pins.

Apply sealant to the crankcase mating surfaces as shown.

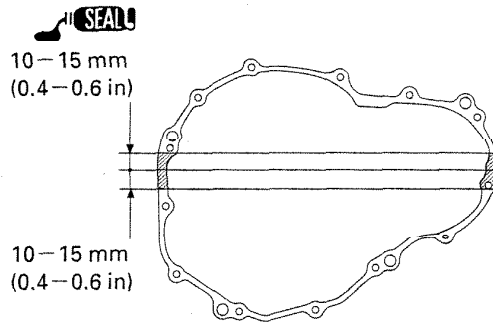

Apply sealant to the right crankcase cover mating surface.

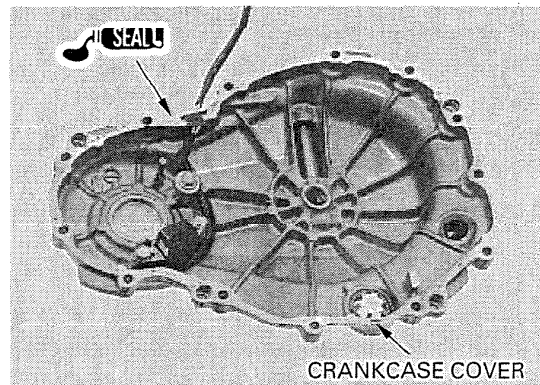
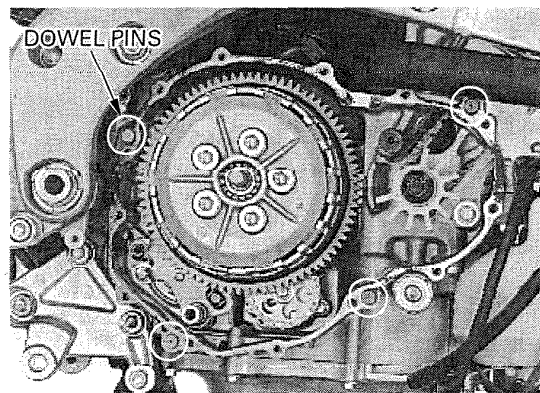

Install the right crankcase cover while turning the lifter arm clockwise to engage the lifter arm groove with the lifter piece flange.

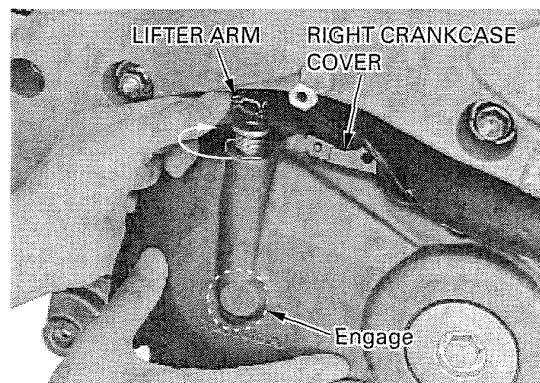

CLUTCH/GEARSHIFT LINKAGE

Install the cover bolts.

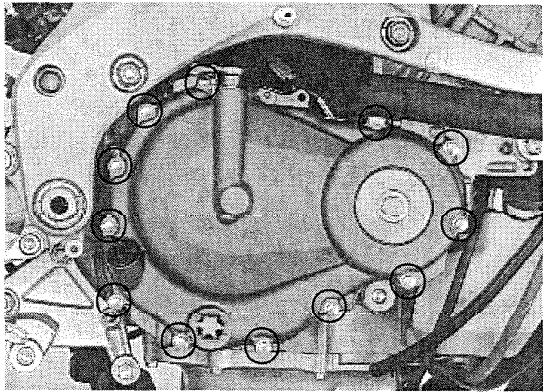

Do not pinch the ignition pulse generator wire between the water hose and engine.

Connect the ignition pulse generator 2P connector.

Connect the clutch cable to the lifter arm and install the cable holder with the bolt.

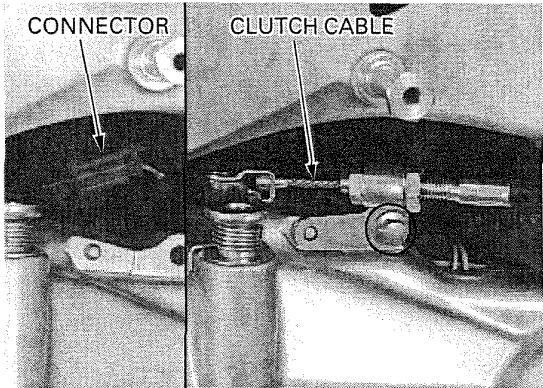

Tighten the four cover bolts first in a numerical order on the crankcase cover in 2 or 3 steps.

TORQUE : 12 N·m (1.2 kgf·m , 9 lbf·ft)

Tighten the other cover bolts to the same torque.

Fill the crankcase with recommended engine oil (page 3-12).

Adjust the clutch cable (page 3-23).

Install the side fairing (page 2-4).

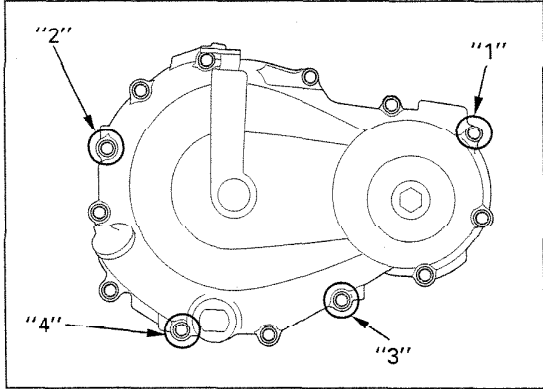

ALTERNATOR/STARTER CLUTCH

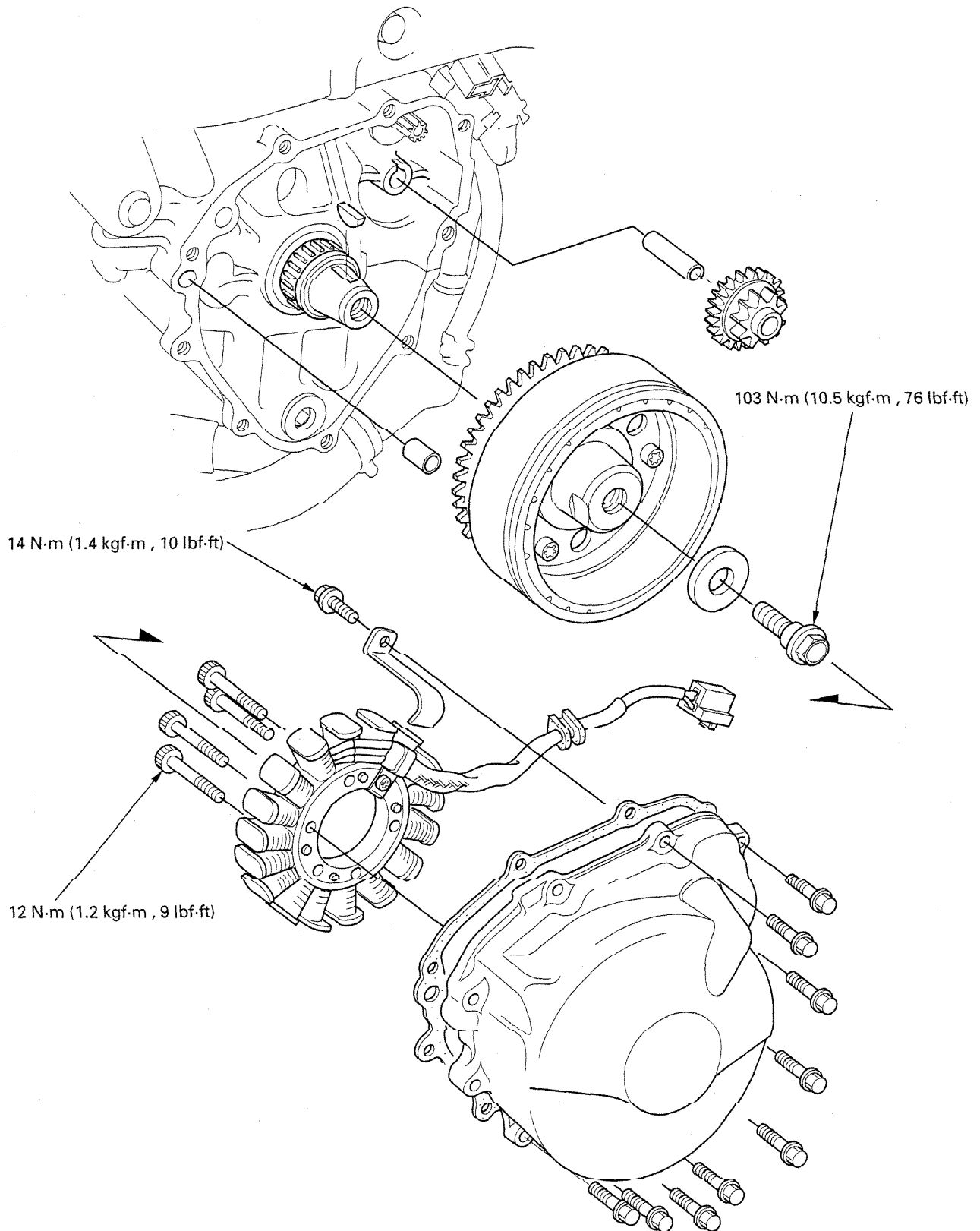

10. ALTERNATOR/STARTER CLUTCH

SERVICE INFORMATION	10-1	FLYWHEEL REMOVAL	10-3
TROUBLESHOOTING	10-1	STARTER CLUTCH	10-4
ALTERNATOR STATOR	10-2	FLYWHEEL INSTALLATION	10-6

SERVICE INFORMATION

GENERAL

- This section covers service of the alternator stator, flywheel and starter clutch. These parts can be removed with the engine installed in the frame.
- Refer to section 16 for alternator stator inspection.
- Refer to section 18 for starter motor servicing.

SPECIFICATIONS

Unit: mm (in)

ITEM	STANDARD	SERVICE LIMIT
Starter driven gear boss O.D.	51.699–51.718 (2.0354–2.0361)	51.684 (2.0348)

TORQUE VALUES

Stator wire clamp bolt	14 N·m (1.4 kgf·m , 10 lbf·ft)	
Alternator stator bolt	12 N·m (1.2 kgf·m , 9 lbf·ft)	
Starter clutch bolt	16 N·m (1.6 kgf·m , 12 lbf·ft)	Apply locking agent to the threads
Flywheel bolt	103 N·m (10.5 kgf·m , 76 lbf·ft)	Apply oil to the threads and seating surface

TOOLS

Flywheel holder	07725-0040000 or equivalent commercially available in U.S.A.
Rotor puller	07733-0020001 or 07933-3950000

TROUBLESHOOTING

Engine does not turn

- Faulty starter clutch
- Damaged reduction gear/shaft

ALTERNATOR/STARTER CLUTCH

ALTERNATOR STATOR

LEFT CRANKCASE COVER REMOVAL

Remove the left side fairing (page 2-4).

Disconnect the alternator 3P (White) connector.
Remove the left crankcase cover bolts and the left crankcase cover.

CAUTION:

The left crankcase cover (stator) is magnetically attached to the flywheel, be careful during removal.

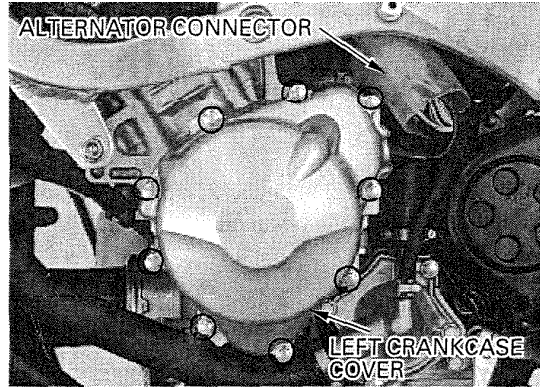

NOTE:

The engine oil will run out when the left crankcase cover is removed. Set a clean oil pan under the engine and add the recommended oil to the specified level after installation.

Remove the gasket and dowel pin.

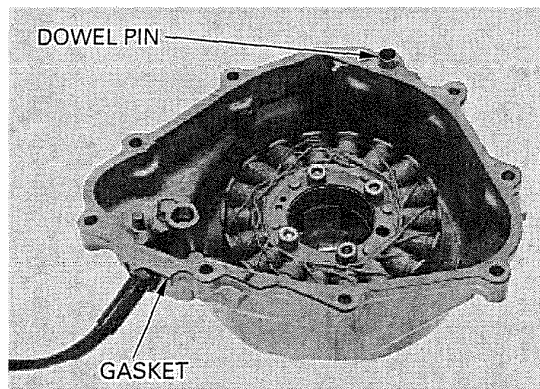

STATOR REPLACEMENT

Remove the clamp bolt and clamp.
Remove the four bolts, grommet and stator from the left crankcase cover.

Install a new stator onto the left crankcase cover.
Apply sealant to the grommet seating surface and install it into the cover groove properly.
Set the wire properly and install the wire clamp with the bolt.

TORQUE : 14 N·m (1.4 kgf·m , 10 lbf·ft)

Install and tighten the stator bolts.

TORQUE : 12 N·m (1.2 kgf·m , 9 lbf·ft)

LEFT CRANKCASE COVER INSTALLATION

Apply sealant to the crankcase mating surfaces as shown.

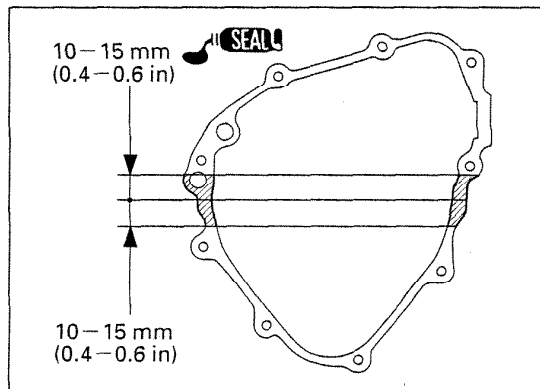
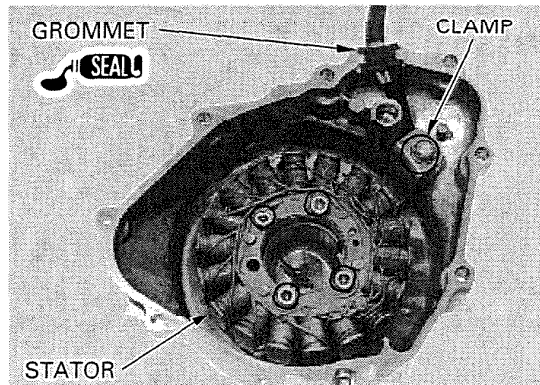

Install the dowel pin and a new gasket.

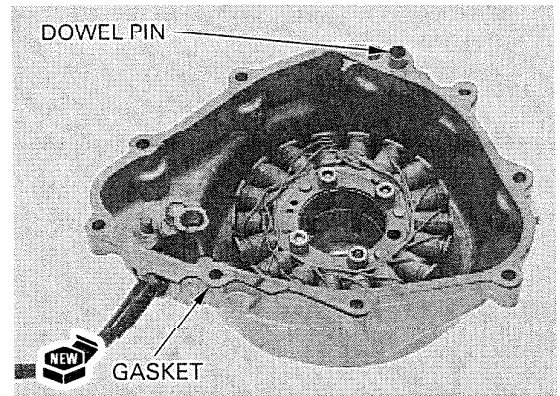

Install the left crankcase cover and tighten the cover bolts securely.

Connect the alternator 3P (White) connector.

Install the left side fairing (page 2-4).
Check the oil level and add recommended engine oil if necessary (page 3-11).

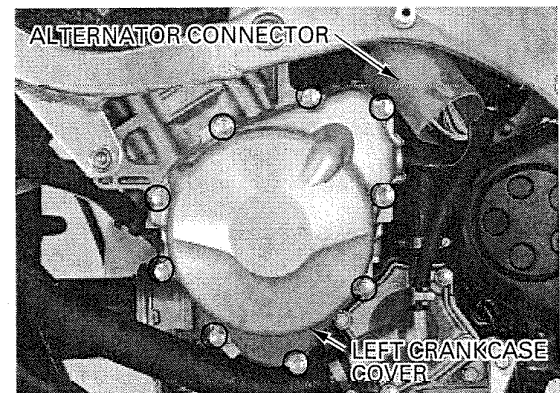

FLYWHEEL REMOVAL

Remove the left crankcase cover (page 10-2).

Remove the starter reduction gear and shaft.

Hold the flywheel with the special tool and loosen the flywheel bolt.

TOOL:
Flywheel holder 07725-0040000 or equivalent commercially available in U.S.A.

Remove the flywheel bolt and special washer.

Remove the flywheel using the special tool.

TOOL:
Rotor puller 07733-0020001 or 07933-3950000

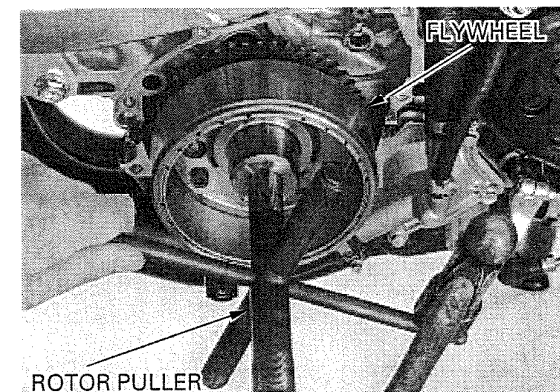
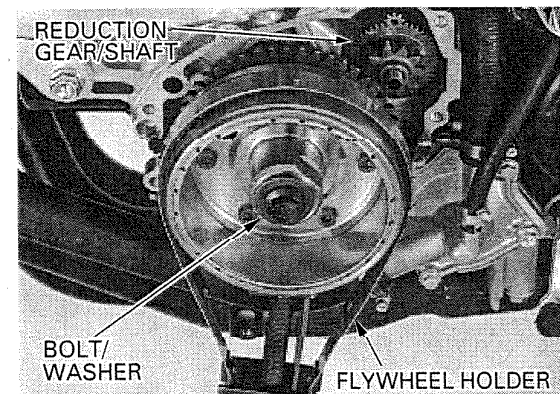

ALTERNATOR/STARTER CLUTCH

Remove the woodruff key from the crankshaft.

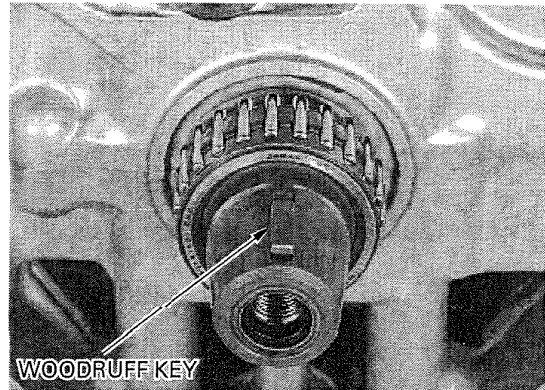

STARTER CLUTCH

REMOVAL

Remove the flywheel (page 10-3).

Remove the starter driven gear while turning it counterclockwise.

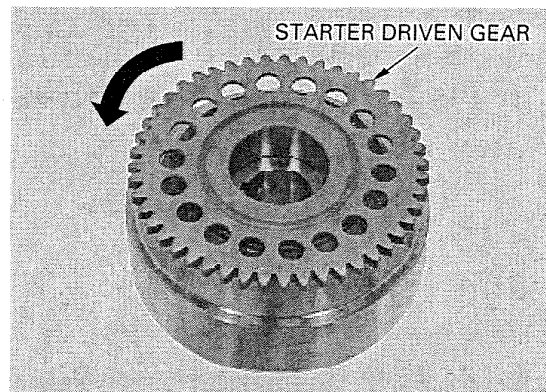

Hold the flywheel with the special tool and remove the starter clutch bolts.

TOOL:
Flywheel holder 07725 0040000 or equivalent commercially available in U.S.A.

Remove the starter clutch assembly from the flywheel.

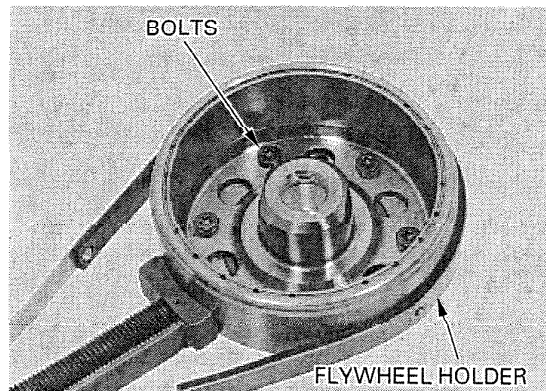

Remove the sprag clutch from the starter clutch outer.

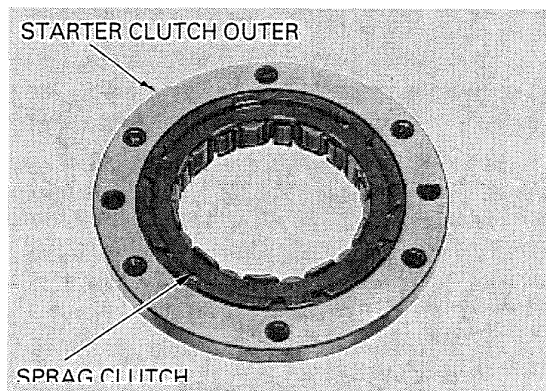

INSPECTION

Check the starter driven gear, reduction gear and sprag clutch for abnormal wear or damage.

Measure the starter driven gear O.D.

SERVICE LIMIT: 51.684 mm (2.0348 in)

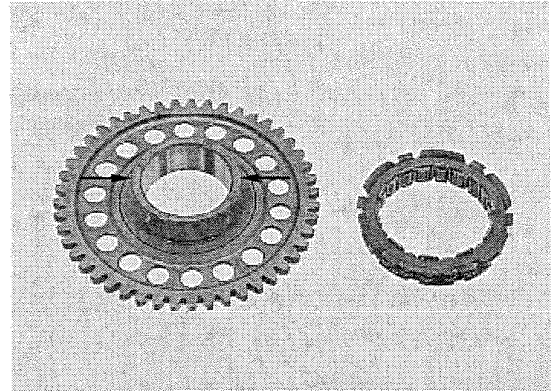

Check the inner contact surface of the clutch outer for damage.

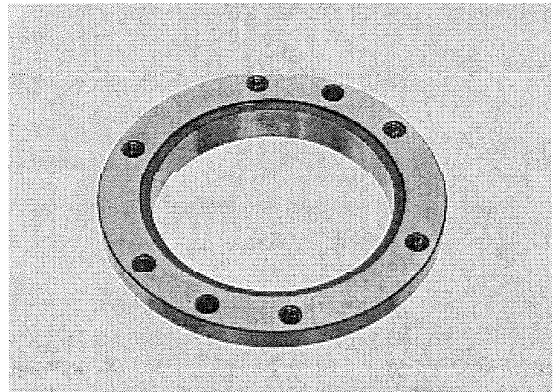

INSTALLATION

Apply engine oil to the sprag clutch contacting surfaces.

Install the sprag clutch into the starter clutch outer as shown.

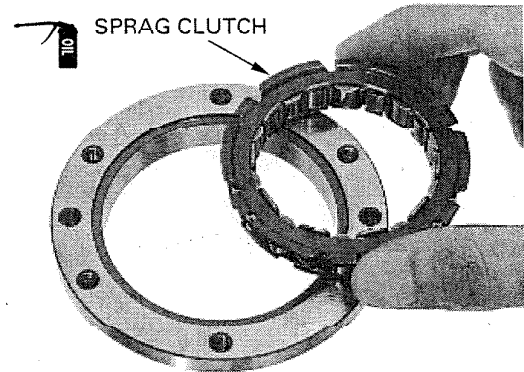

Apply locking agent to the starter clutch bolt threads.

Install the starter clutch assembly onto the flywheel and install the bolts.

Hold the flywheel with the special tool and tighten the bolts.

TOOL:

Flywheel holder

07725-0040000 or equivalent commercially available in U.S.A.

TORQUE: 16 N.m (1.6 kgf.m, 12 lbf.ft)

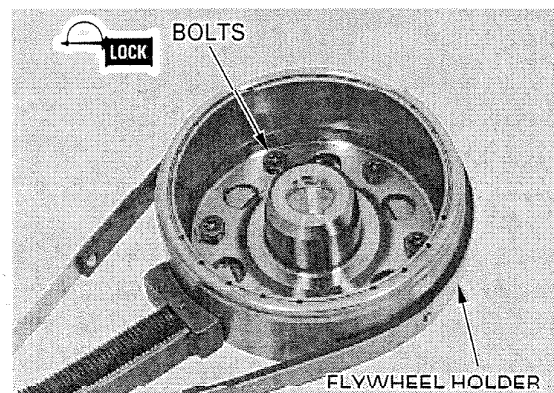

ALTERNATOR/STARTER CLUTCH

Install the starter driven gear while turning it counterclockwise.

Make sure that the starter driven gear turns counterclockwise smoothly and does not turn clockwise.

Install the flywheel (see below).

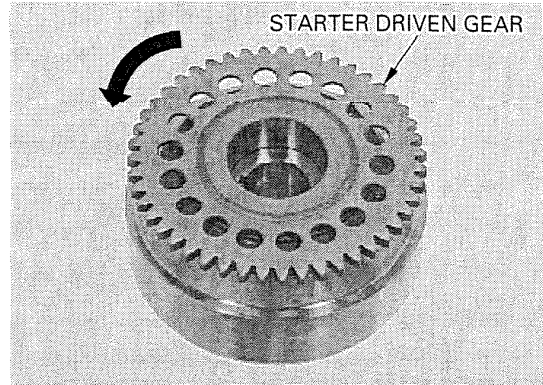

FLYWHEEL INSTALLATION

Apply oil to the needle bearing.

Clean any oil from the tapered portion of the crankshaft and flywheel.

Install the woodruff key in the crankshaft key groove.

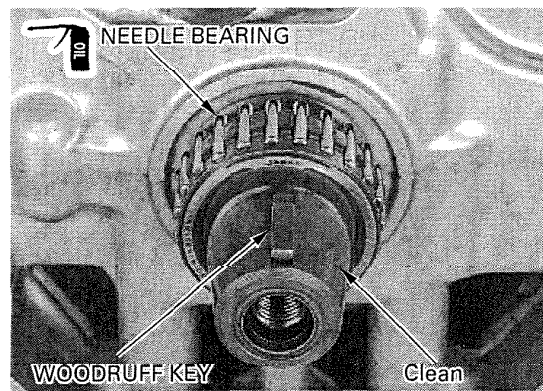

Install the flywheel aligning the key way in the flywheel with the woodruff key on the crankshaft.

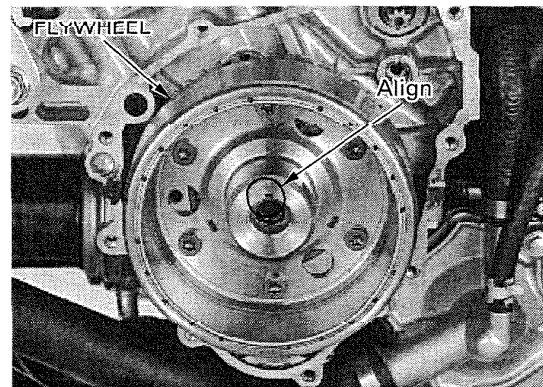

Apply engine oil to the flywheel bolt threads and seating surface.

Install the special washer and flywheel bolt.

Hold the flywheel with the special tool and tighten the bolt.

TOOL:

Flywheel holder 07725-0040000 or equivalent commercially available in U.S.A.

TORQUE : 103 N-m (10.5 kgf-m , 76 lbf-ft)

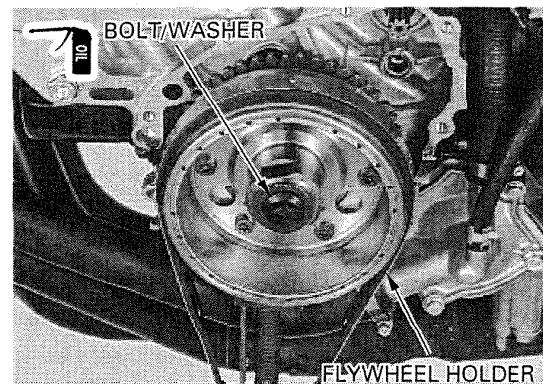

ALTERNATOR/STARTER CLUTCH

Apply oil to the starter reduction gear and gear shaft.

Install the reduction gear and shaft.

Install the left crankcase cover (page 10-2).

