

LUBRICATION SYSTEM

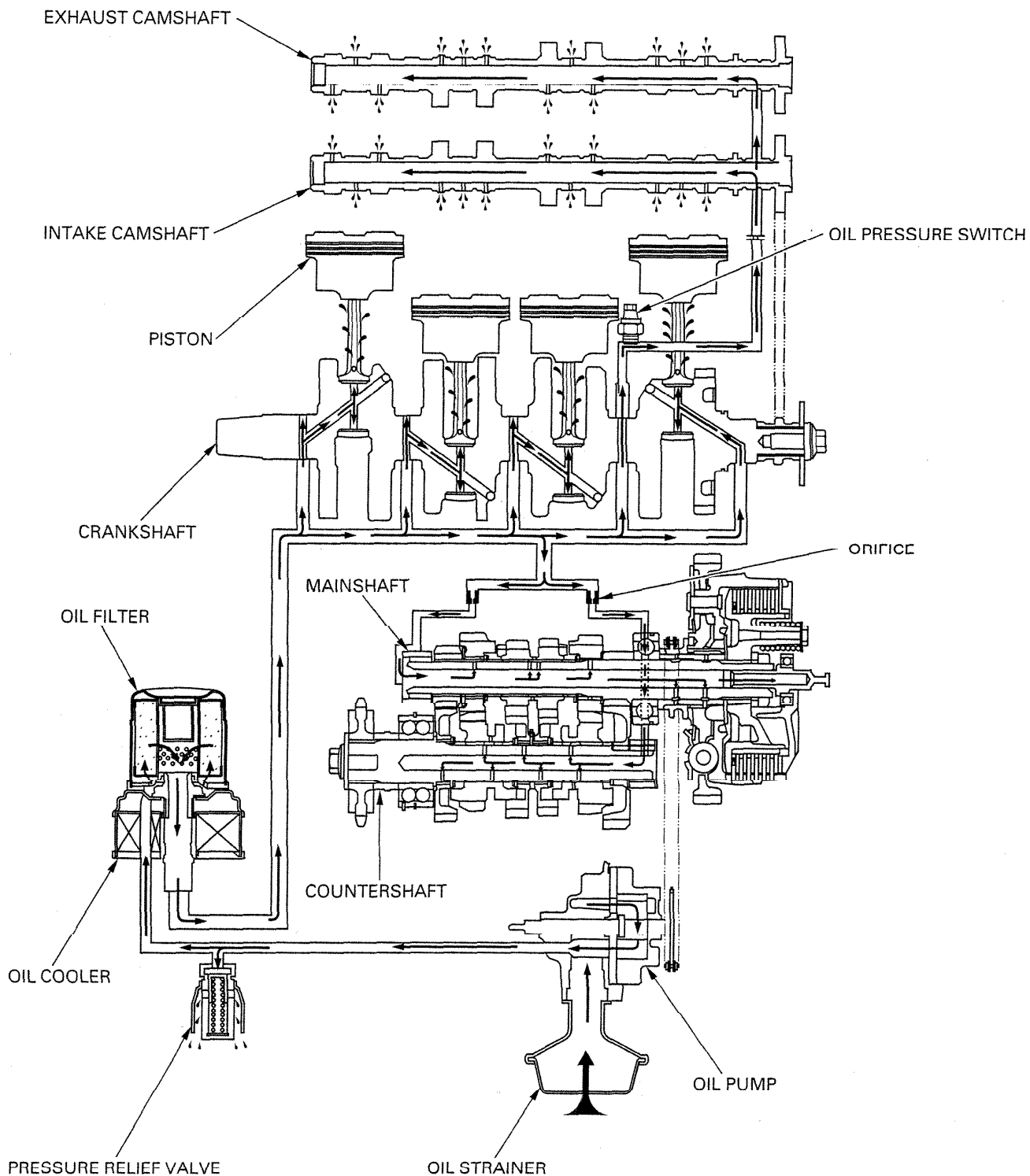

4. LUBRICATION SYSTEM

SERVICE INFORMATION	4-1	OIL STRAINER/PRESSURE RELIEF VALVE	4-4
TROUBLESHOOTING	4-2	OIL PUMP	4-6
OIL PRESSURE CHECK	4-3	OIL COOLER	4-8

SERVICE INFORMATION

GENERAL

4

▲WARNING

- When the engine must be running to do some work, make sure the area is well-ventilated. Never run the engine in an enclosed area. The exhaust contains poisonous carbon monoxide gas that may cause loss of consciousness and lead to death. Run the engine in an open area or with an exhaust evacuation system in an enclosed area.
- Used engine oil may cause skin cancer if repeatedly left in contact with the skin for prolonged periods. Although this is unlikely unless you handle used oil on a daily basis, it is still advisable to thoroughly wash your hands with soap and water as soon as possible after handling used oil. KEEP OUT OF REACH OF CHILDREN.

- The service procedures in this section can be performed with the engine installed in the frame.
- If any portion of the oil pump is worn beyond the specified service limits, replace the oil pump as an assembly.
- For engine oil level check, see page 3-11.
- For engine oil and filter change, see page 3-12.
- For oil pressure indicator inspection, see page 19-12.

SPECIFICATIONS

Unit: mm (in)

ITEM		STANDARD	SERVICE LIMIT
Engine oil capacity	After draining	3.0 ℓ (3.2 US qt, 2.6 Imp qt)	_____
	After draining/filter change	3.3 ℓ (3.5 US qt, 2.9 Imp qt)	_____
	After disassembly	3.7 ℓ (3.9 US qt, 3.3 Imp qt)	_____
Recommended engine oil		Honda GN4 4-stroke oil or equivalent motor oil API service classification SF or SG Viscosity: SAE 10W-40	_____
Oil pressure (at oil main gallery)		490 kPa (5.0 kgf/cm ² , 71 psi) at 6,000 rpm/80 °C (176 °F)	_____
Oil pump	Tip clearance	0.15 (0.006)	0.20 (0.008)
	Body clearance	0.15 – 0.22 (0.006 – 0.009)	0.35 (0.014)
	Side clearance	0.02 – 0.07 (0.001 – 0.003)	0.10 (0.004)

TORQUE VALUES

Oil main gallery sealing bolt	29 N·m (3.0 kgf·m, 22 lbf·ft)	Apply locking agent to the threads
Oil pressure switch	12 N·m (1.2 kgf·m, 9 lbf·ft)	Apply sealant to the threads (page 4-4)
Oil pressure switch terminal screw	2 N·m (0.2 kgf·m, 1.4 lbf·ft)	
Oil pump cover bolt	8 N·m (0.8 kgf·m, 5.8 lbf·ft)	
Oil cooler bolt (filter boss)	64 N·m (6.5 kgf·m, 47 lbf·ft)	Apply oil to the threads and seating surface

TOOLS:

Oil pressure gauge	07506-3000000	□ or equivalent commercially available in U.S.A.
Oil pressure gauge attachment	07510 MJ10100	

LUBRICATION SYSTEM

TROUBLESHOOTING

Oil level too low

- Oil consumption
- External oil leak
- Worn piston rings
- Improperly installed piston rings
- Worn cylinders
- Worn stem seals
- Worn valve guide

Low oil pressure

- Oil level low
- Clogged oil strainer
- Faulty oil pump
- Internal oil leak
- Incorrect oil being used

No oil pressure

- Oil level too low
- Oil pressure relief valve stuck open
- Broken oil pump drive chain
- Broken oil pump drive or driven sprocket
- Damaged oil pump
- Internal oil leak

High oil pressure

- Oil pressure relief valve stuck closed
- Clogged oil gallery or metering orifice
- Incorrect oil being used

Oil contamination

- Oil or filter not changed often enough
- Worn piston rings

Oil emulsification

- Blown cylinder head gasket
- Leaky coolant passage
- Entry of water

OIL PRESSURE CHECK

Remove the right side fairing (page 2-4).

Start the engine and warm it up to normal operating temperature.

Stop the engine, remove the oil main gallery sealing bolt.

Connect an oil pressure gauge attachment and gauge to the bolt hole, use care not to allow any locking agent material to enter the engine.

TOOLS:

- Oil pressure gauge** 07506-3000000 or equivalent commercially available in U.S.A.
- Pressure gauge attachment** 07510-MJ10100 or equivalent commercially available in U.S.A.

Check the oil level and add the recommended oil if necessary (page 3-11).

Start the engine and check the oil pressure at 6,000 rpm/80 °C (176 °F).

OIL PRESSURE: 490 kPa (5.0 kgf/cm², 71 psi)

Stop the engine.

Clean the sealing bolt threads thoroughly. Apply locking agent to the sealing bolt threads and install it.

TORQUE : 29 N·m (3.0 kgf·m, 22 lbf·ft)

Install the right side fairing (page 2-4).

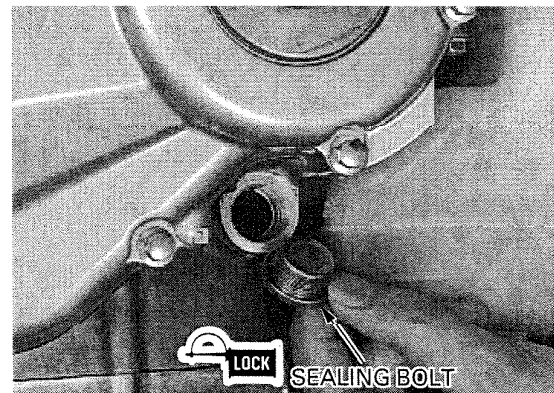
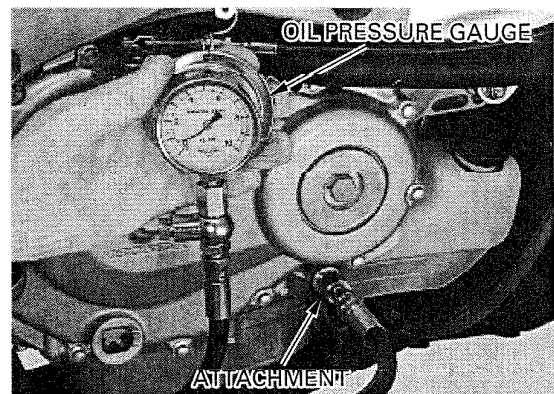
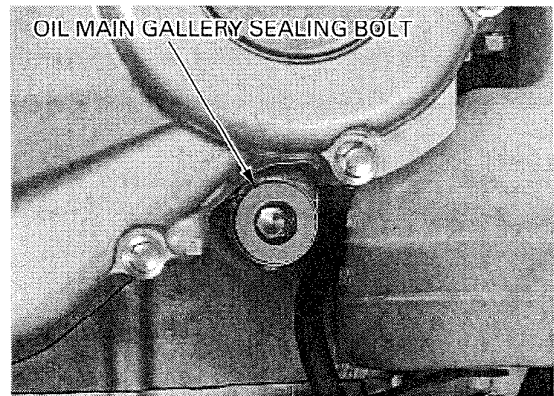

OIL PRESSURE SWITCH REPLACEMENT

Remove the fuel tank (page 2-3).

Remove the rubber cap and disconnect the switch wire by removing the terminal screw. Remove the oil pressure switch.

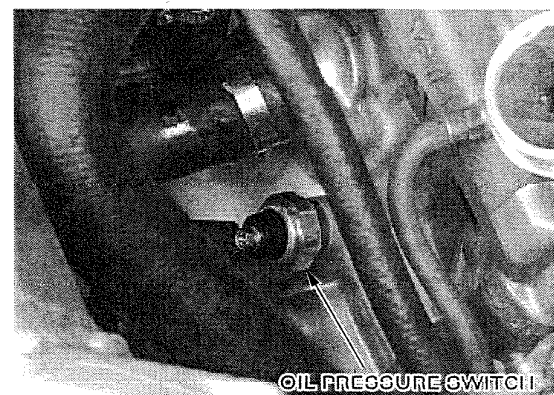

LUBRICATION SYSTEM

Apply sealant to the oil pressure switch threads as shown and install it.

TORQUE : 12 N·m (1.2 kgf·m , 9 lbf·ft)

CAUTION:

To prevent crankcase damage, do not overtighten the switch.

Connect the oil pressure switch wire and tighten the terminal screw.

TORQUE : 2 N·m (0.2 kgf·m , 1.4 lbf·ft)

Install the rubber cap properly.

Install the fuel tank (page 2-3).

Start the engine.

Check that the oil pressure indicator goes out after one or two seconds.

If the oil pressure indicator stays on, stop the engine and check the indicator system (page 19-12).

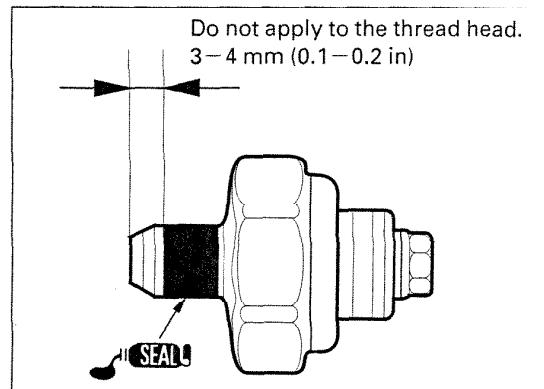

OIL STRAINER/PRESSURE RELIEF VALVE

OIL PAN REMOVAL

Drain the engine oil (page 3-12).
Remove the exhaust pipe (page 2-7).

Remove the reserve tank breather tube from the stay.
Remove the eleven bolts and the oil pan.

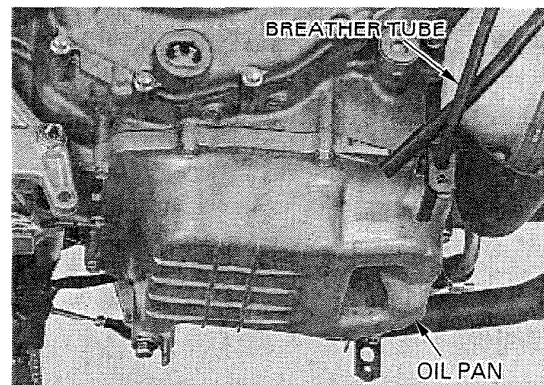

OIL STRAINER

Remove the oil strainer and seal rubber from the oil pump.

Clean the oil strainer screen thoroughly.

Coat a new seal rubber with oil and install it onto the strainer.

Install the oil strainer by aligning its tab with the groove in the crankcase.

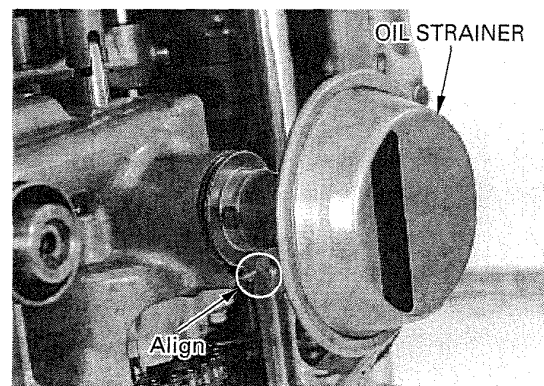

OIL PRESSURE RELIEF VALVE

Remove the oil pressure relief valve from the crankcase.
Remove the O-ring from the relief valve body.

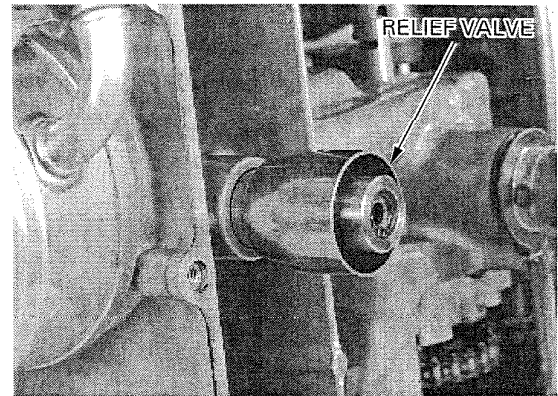

Remove the snap ring.
Remove the spring seat, spring and piston from the valve body.

Check the piston for wear, sticking or other damage.
Check the spring for fatigue or damage.

Install the piston, spring and spring seat and secure them with the snap ring.

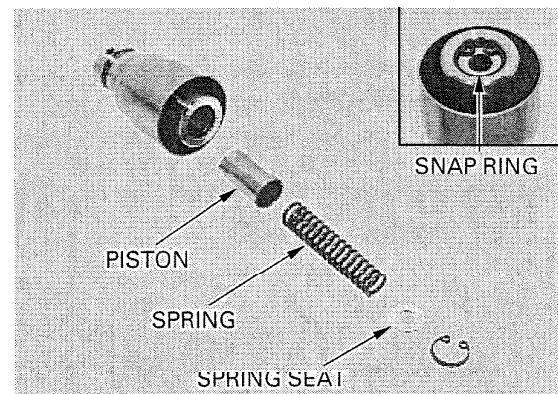

Coat a new O-ring with oil and install it into the relief valve body groove.
Install the relief valve into the crankcase.

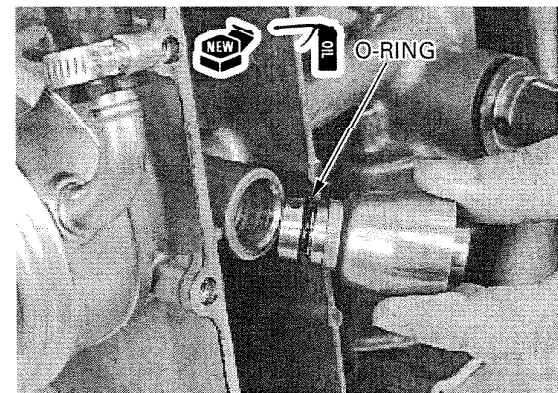

OIL PAN INSTALLATION

Clean the oil pan mating surfaces thoroughly, being careful not to damage them.
Apply sealant to the oil pan mating surface.

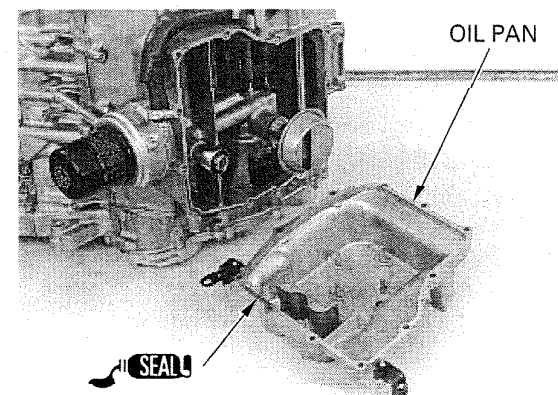

LUBRICATION SYSTEM

- Install the oil pan and tighten the eleven bolts in a crisscross pattern in 2 or 3 steps.
Install the breather tube into the stay.
Route the tube properly (page 1-18).
Install the exhaust pipe and muffler (page 2-7).
Fill the crankcase with recommended engine oil (page 3-12).

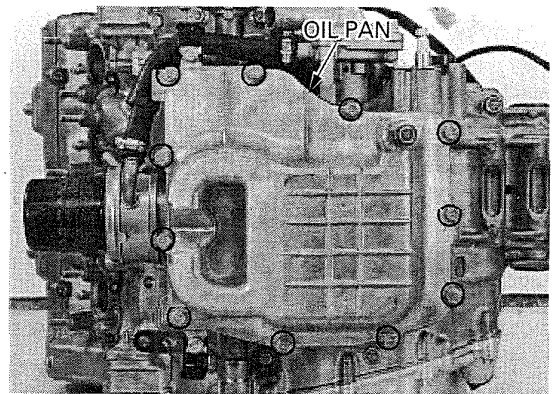

OIL PUMP

REMOVAL

Remove the clutch and oil pump driven sprocket (page 9-3).

Remove the three mounting bolts and oil pump.

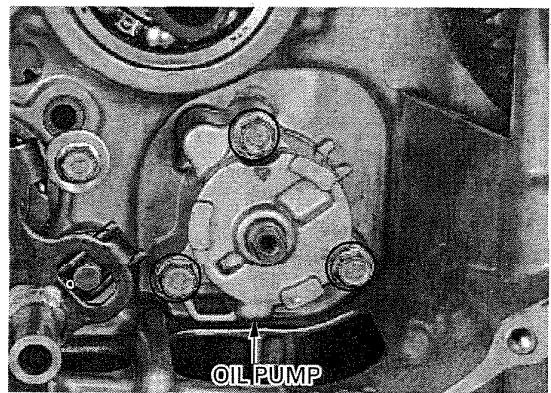

DISASSEMBLY

Remove the following:

- dowel pins
- bolt and pump cover

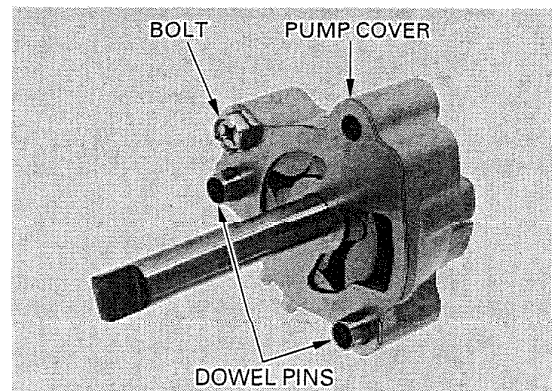

- pump shaft
- thrust washer
- drive pin
- inner and outer rotors.

Clean the disassembled parts thoroughly.

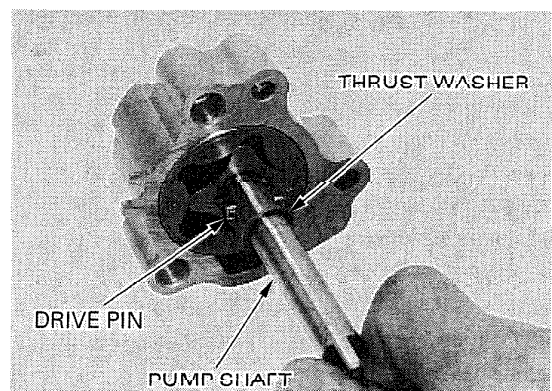

INSPECTION

NOTE:

If any portion of the oil pump is worn beyond the service limit, replace the oil pump as an assembly.

Temporarily assemble the oil pump.
Measure the rotor tip clearance.

SERVICE LIMIT: 0.20 mm (0.008 in)

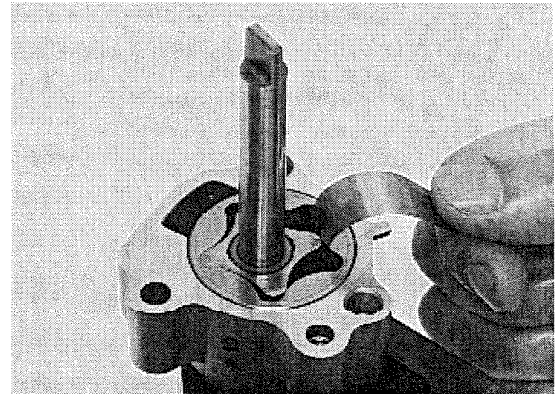

Measure the pump body clearance.

SERVICE LIMIT: 0.35 mm (0.014 in)

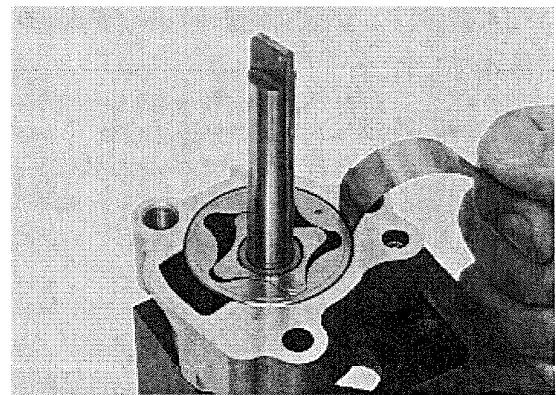

Measure the pump side clearance.

SERVICE LIMIT: 0.10 mm (0.004 in)

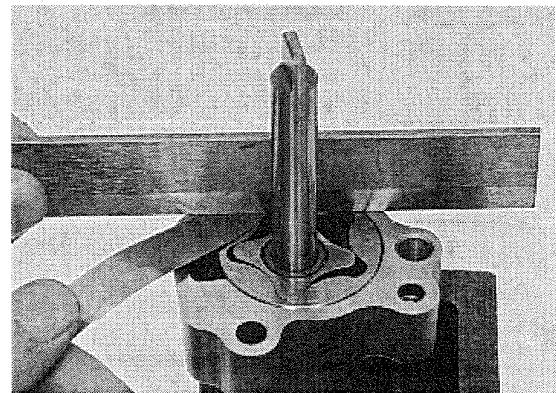

ASSEMBLY

Install the outer and inner rotors into the pump body with the driver pin grooves in the inner rotor facing the pump cover.

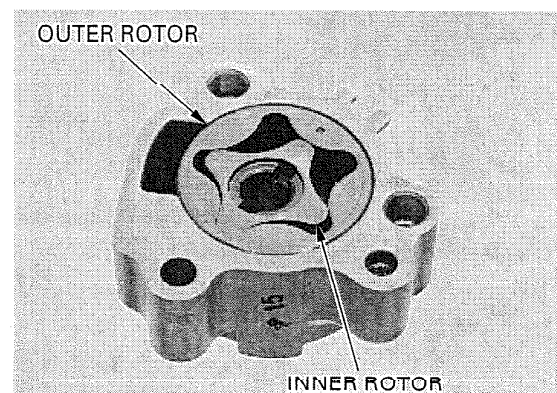

LUBRICATION SYSTEM

Install the drive pin into the pump shaft.
Install the pump shaft by aligning the pin with the grooves in the inner rotor.
Install the thrust washer onto the inner rotor.

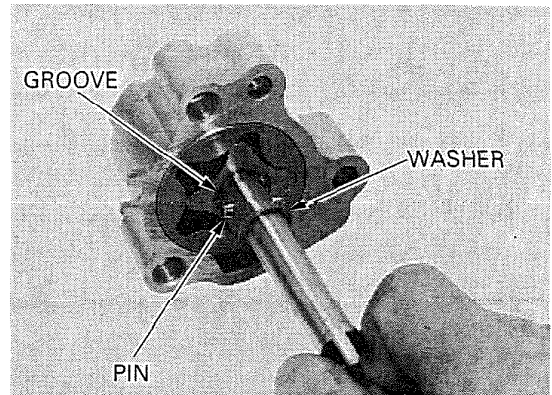

Install the pump cover and dowel pins, and tighten the bolt.

TORQUE : 8 N·m (0.8 kgf·m , 5.8 lbf·ft)

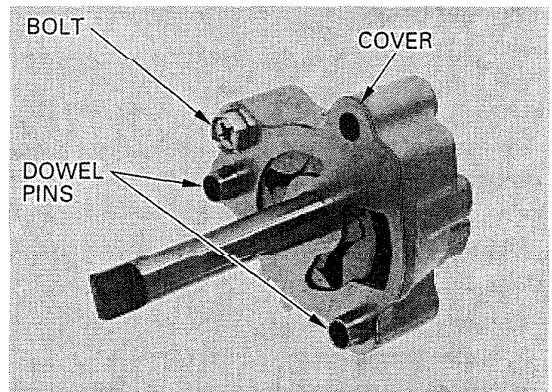

INSTALLATION

Install the oil pump onto the crankcase while aligning the pump shaft lug with the water pump shaft groove by turning the pump shaft.

Install the pump mounting bolts and tighten them.

Install the clutch assembly (page 9-9).

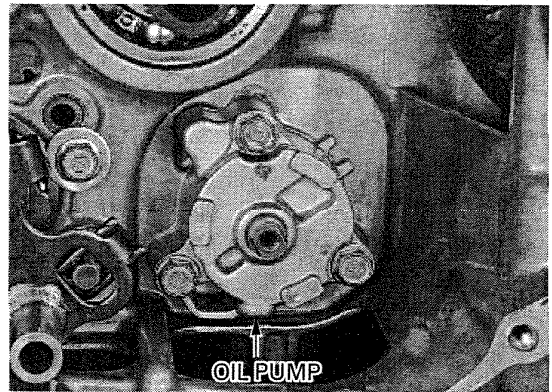

OIL COOLER

REMOVAL

Remove the oil filter (page 3-12).
Drain the coolant from the system (page 6-5).
Disconnect the water hoses from the oil cooler.

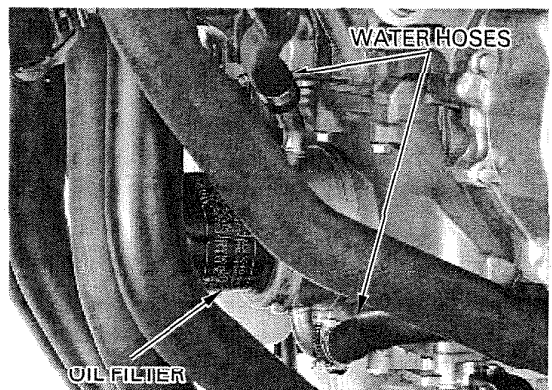

Remove the oil cooler bolt (filter boss), washer and oil cooler.
Remove the O-ring from the oil cooler.

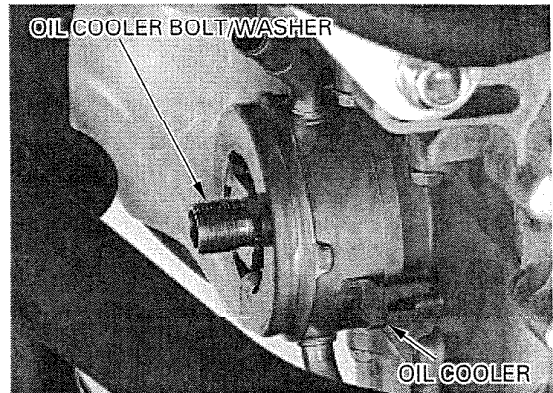

INSPECTION

Check the oil cooler for damage.

INSTALLATION

Coat a new O-ring with oil and install it into the oil cooler groove.

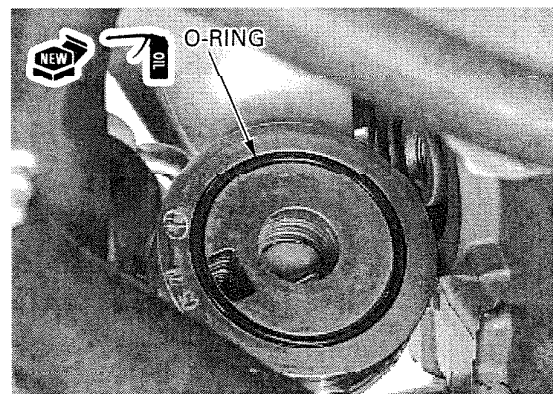

Apply engine oil to the oil cooler bolt threads and seating surface.
Install the oil cooler by aligning the guide groove with the lug on the crankcase. Install the cooler bolt and washer with the concave of the washer ("O" mark) facing the oil cooler.
Tighten the cooler bolt.

TORQUE : 64 N·m (6.5 kgf·m , 47 lbf·ft)

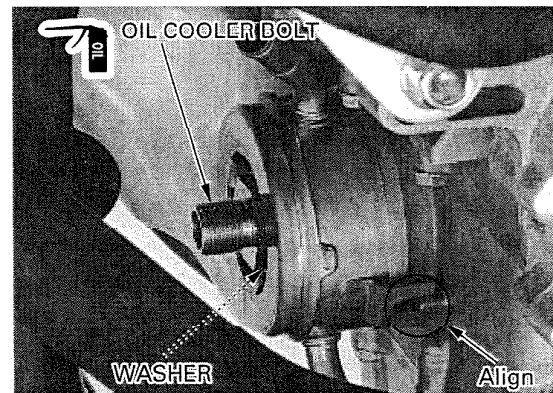
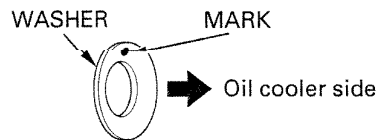

Connect the water hoses to the oil cooler.

Install the oil filter (page 3-12).
Fill and bleed the cooling system (page 6-4).

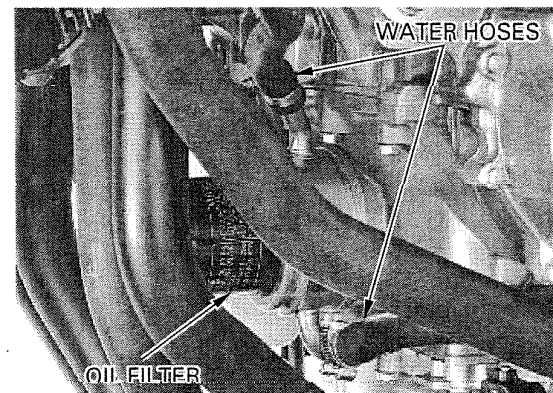

FUEL SYSTEM

California type shown:

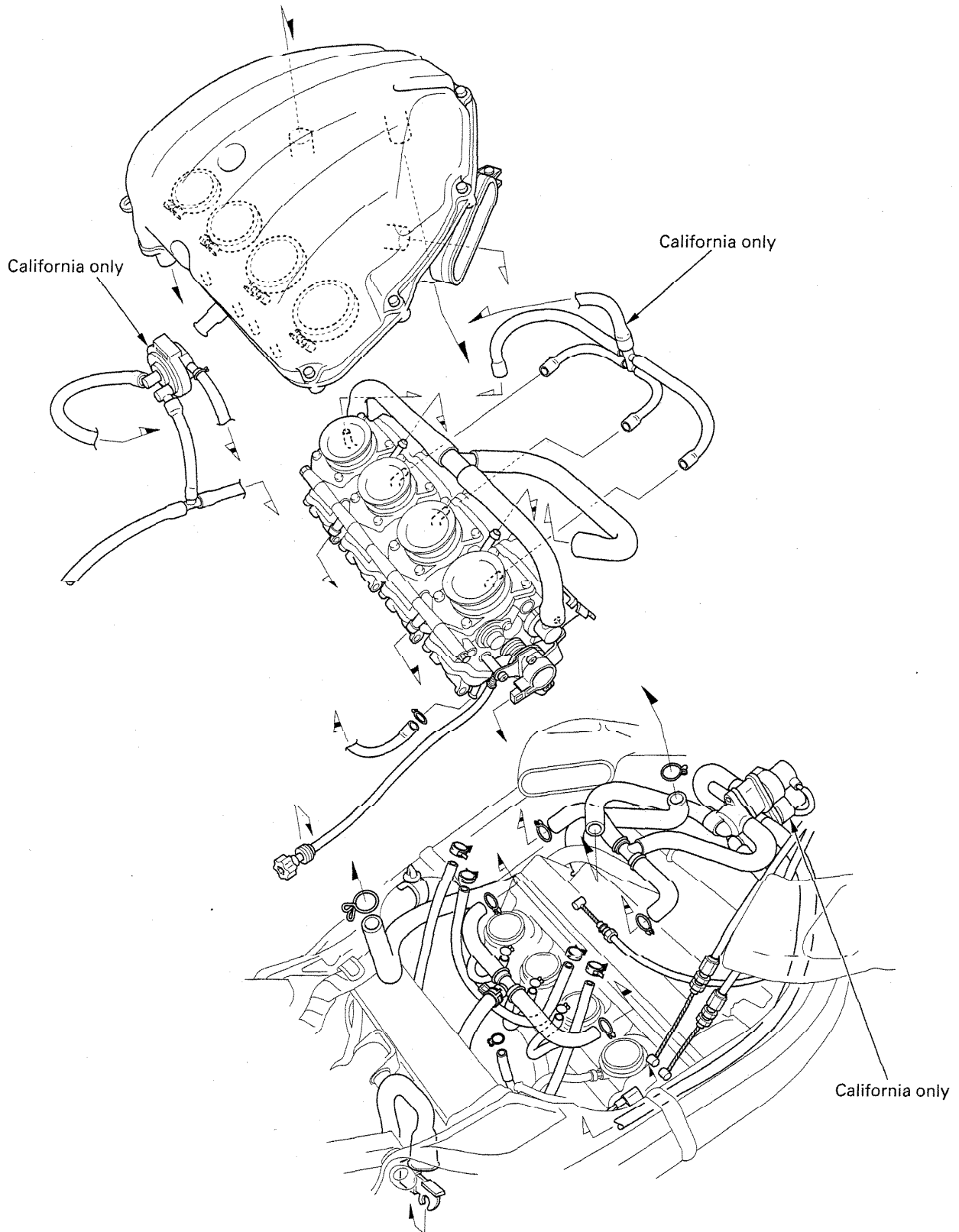

5. FUEL SYSTEM

SERVICE INFORMATION	5-3	CARBURETOR INSTALLATION	5-30
TROUBLESHOOTING	5-5	PILOT SCREW ADJUSTMENT	5-33
AIR CLEANER HOUSING	5-14	HIGH ALTITUDE ADJUSTMENT	5-34
CARBURETOR REMOVAL	5-15	DIRECT AIR INDUCTION (D.A.I.) SYSTEM	5-36
CARBURETOR SEPARATION	5-16	FUEL PUMP	5-37
CARBURETOR DISASSEMBLY/ INSPECTION	5-18	SECONDARY AIR SUPPLY SYSTEM	5-37
CARBURETOR ASSEMBLY	5-22	EVAPORATIVE EMISSION CONTROL SYSTEM (California type only)	5-39
CARBURETOR COMBINATION	5-26		

DIRECT AIR INDUCTION (D.A.I.) SYSTEM AIR FLOW PATTERN
49 state/Canada type:

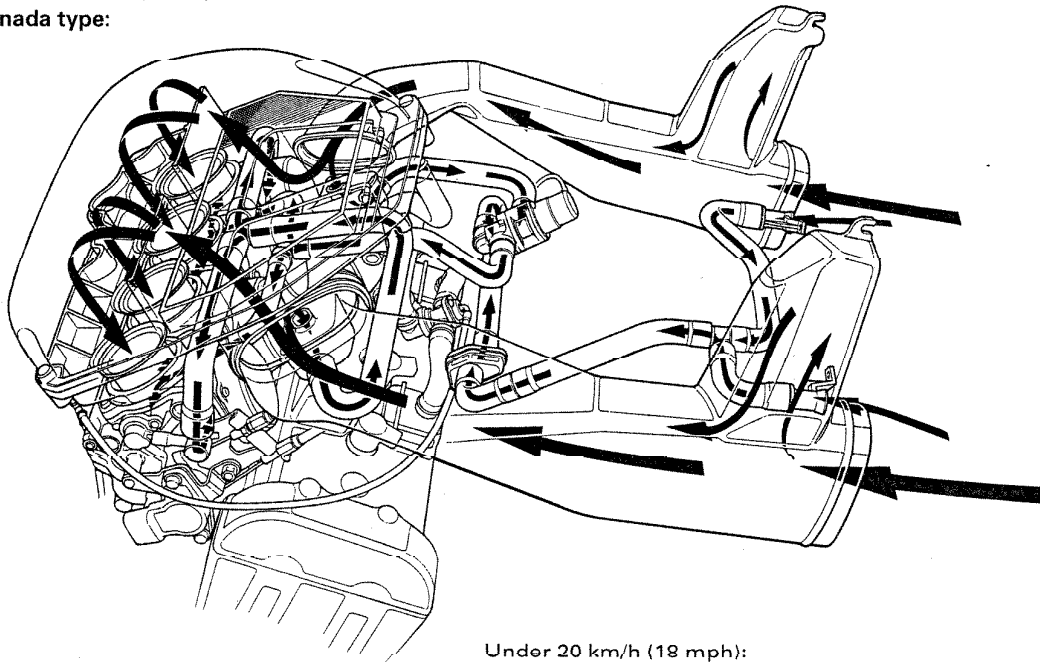

Over 20 km/h (18 mph):

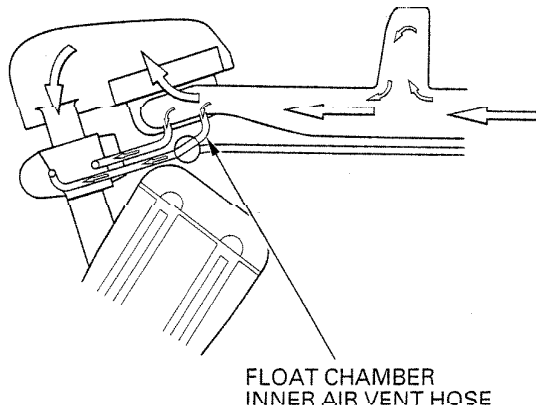

Under 20 km/h (18 mph):

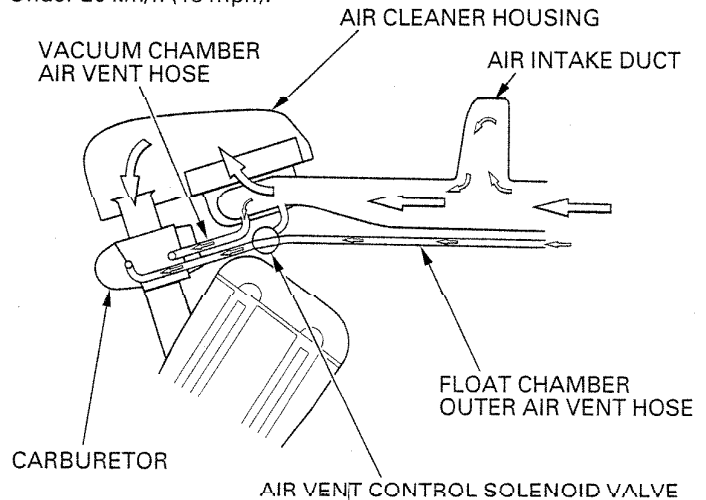

FUEL SYSTEM

California type:

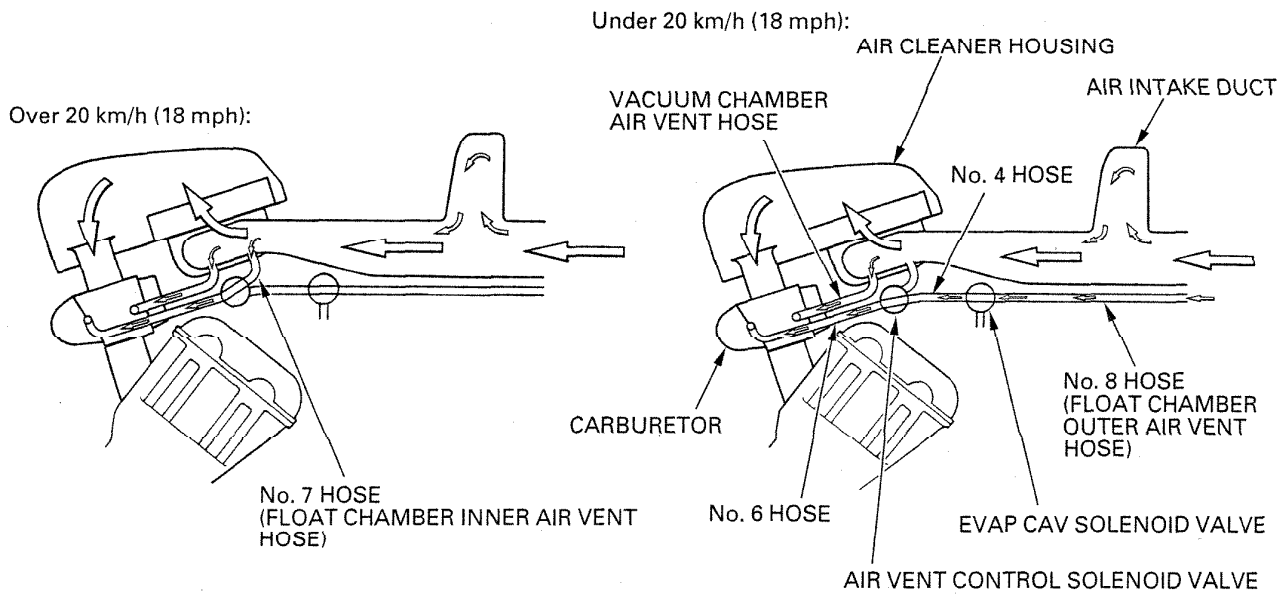
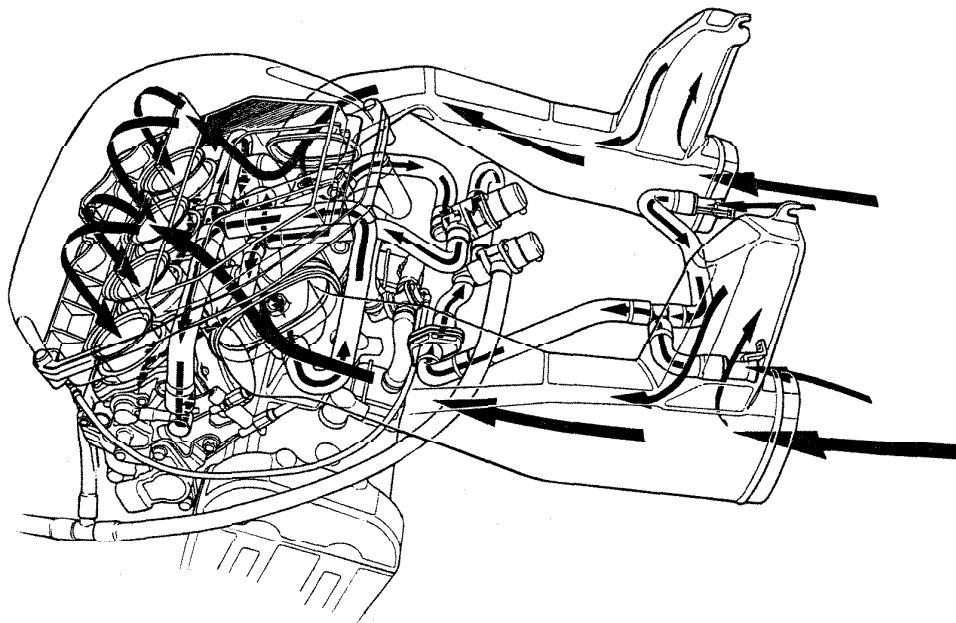

SERVICE INFORMATION

GENERAL

▲WARNING

- *Gasoline is extremely flammable and is explosive under certain conditions. KEEP OUT OF REACH OF CHILDREN.*
 - *When the engine must be running to do some work, make sure the area is well-ventilated. Never run the engine in an enclosed area. The exhaust contains poisonous carbon monoxide gas that may cause loss of consciousness and lead to death. Run the engine in an open area or with an exhaust evacuation system in an enclosed area.*
 - *Bending or twisting the control cables will impair smooth operation and could cause the cable to stick or bind, resulting in loss of vehicle control.*
-

- Work in a well ventilated area. Smoking or allowing flames or sparks in the work area or where gasoline is stored can cause a fire or explosion.

CAUTION:

Be sure to remove the diaphragms before cleaning air and fuel passages with compressed air. The diaphragms might be damaged.

- For fuel tank and air intake duct removal and installation, see page 2-3.
- For throttle sensor inspection and replacement, see page 17-7.
- For carburetor synchronization, see page 3-13.
- Before disassembling the carburetors, place an approved fuel container under the carburetors, loosen the drain screws and drain the carburetors.
- After removing the carburetors, cover the intake ports of the cylinder heads with a piece of tape to prevent any foreign material from dropping into the engine.
- When disassembling the fuel system parts, note the locations of the O-rings. Replace them with new ones on reassembly.
- The vacuum chamber and float chamber can be serviced with the carburetors combined.

NOTE:

If the vehicle is to be stored for more than one month, drain the float bowls. Fuel left in the float bowls may cause clogged jets, resulting in hard starting or poor driveability.

FUEL SYSTEM

SPECIFICATIONS

ITEM		SPECIFICATIONS
Carburetor identification number	49 state/Canada type	VP64C
	California type	VP64B
Main jet	49 state/Canada type	No. 1/4 carburetor: # 132 , No. 2/3 carburetor: # 135
	California type	# 128 (all carburetors)
Slow jet		# 40
Pilot screw	initial/final opening	See page 5-33
	high altitude adjustment	See page 5-34
Float level		13.7 ± 0.5 mm (0.54 ± 0.02 in)
Idle speed	49 state/Canada type	1,300 ± 100 rpm
	California type	1,400 ± 100 rpm
Carburetor vacuum difference (base carburetor: No. 4)		Within 30 mm Hg (1.2 in Hg)
Fuel pump flow capacity (minimum)		700 cm ³ (23.7 US oz , 24.6 Imp oz) /minute
Throttle grip free play		2–6 mm (1/16–1/4 in)

TORQUE VALUES

Starting enrichment (SE) valve nut	2 N·m (0.2 kgf·m , 1.4 lbf·ft)
Carburetor connecting nut (6 mm)	9 N·m (0.9 kgf·m , 6.5 lbf·ft)
(5 mm)	5 N·m (0.5 kgf·m , 3.6 lbf·ft)
Reed valve cover bolt	13 N·m (1.3 kgf·m , 9 lbf·ft)

TOOL

Float level gauge	07401-0010000
Pilot screw wrench	07KMA-MN90100 or 07KMA-MS60101

TROUBLESHOOTING

Engine cranks but won't start

- No fuel in tank
- No fuel to carburetor
 - Clogged fuel filter
 - Clogged fuel line
 - Clogged fuel tank breather tube
- Too much fuel getting to the engine
 - Clogged air cleaner
 - Flooded carburetor
- Intake air leak
- Contaminated/deteriorated fuel
- Improper choke operation
- Improper throttle operation
- Fuel pump system malfunction
- No spark at plug (faulty ignition system—section 17)

Engine stalls, hard to start, rough idling

- Restricted fuel line
- Fuel mixture too lean/rich
- Contaminated/deteriorated fuel
- Intake air leak
- Misadjusted idle speed
- Misadjusted pilot screw
- Restricted fuel tank breather tube
- Clogged air cleaner
- Clogged slow circuit
- Starting enrichment valve open
- Fuel pump system malfunction
- D.A.I. system malfunction
- Faulty EVAP CAV and/or EVAP purge control system (California type)
- Faulty ignition system (section 17)

Afterburn when engine braking is used

- Lean mixture in slow circuit
- Faulty air cut-off valve
- Faulty pulse secondary air injection (PAIR) system
- Faulty ignition system (section 17)

Backfiring or misfiring during acceleration

- Lean mixture
- Faulty ignition system (section 17)

Poor performance (driveability)

- Clogged fuel system
- Fuel pump system malfunction
- D.A.I. system malfunction
- Faulty EVAP CAV control system (California type)
- Faulty ignition system (section 17)

Lean mixture

- Clogged fuel jets
- Faulty float valve
- Float level too low
- Restricted fuel line
- Restricted fuel tank breather tube
- Intake air leak
- Faulty vacuum piston
- Fuel pump system malfunction
- Faulty EVAP CAV control system (California type)

Rich mixture

- Starting enrichment valve open
- Clogged air jets
- Faulty float valve
- Float level too high
- Dirty air cleaner
- Faulty vacuum piston
- Faulty EVAP purge control system (California type)

FUEL SYSTEM

Direct Air Induction (D.A.I.) system malfunction (49 STATE/CANADA type)

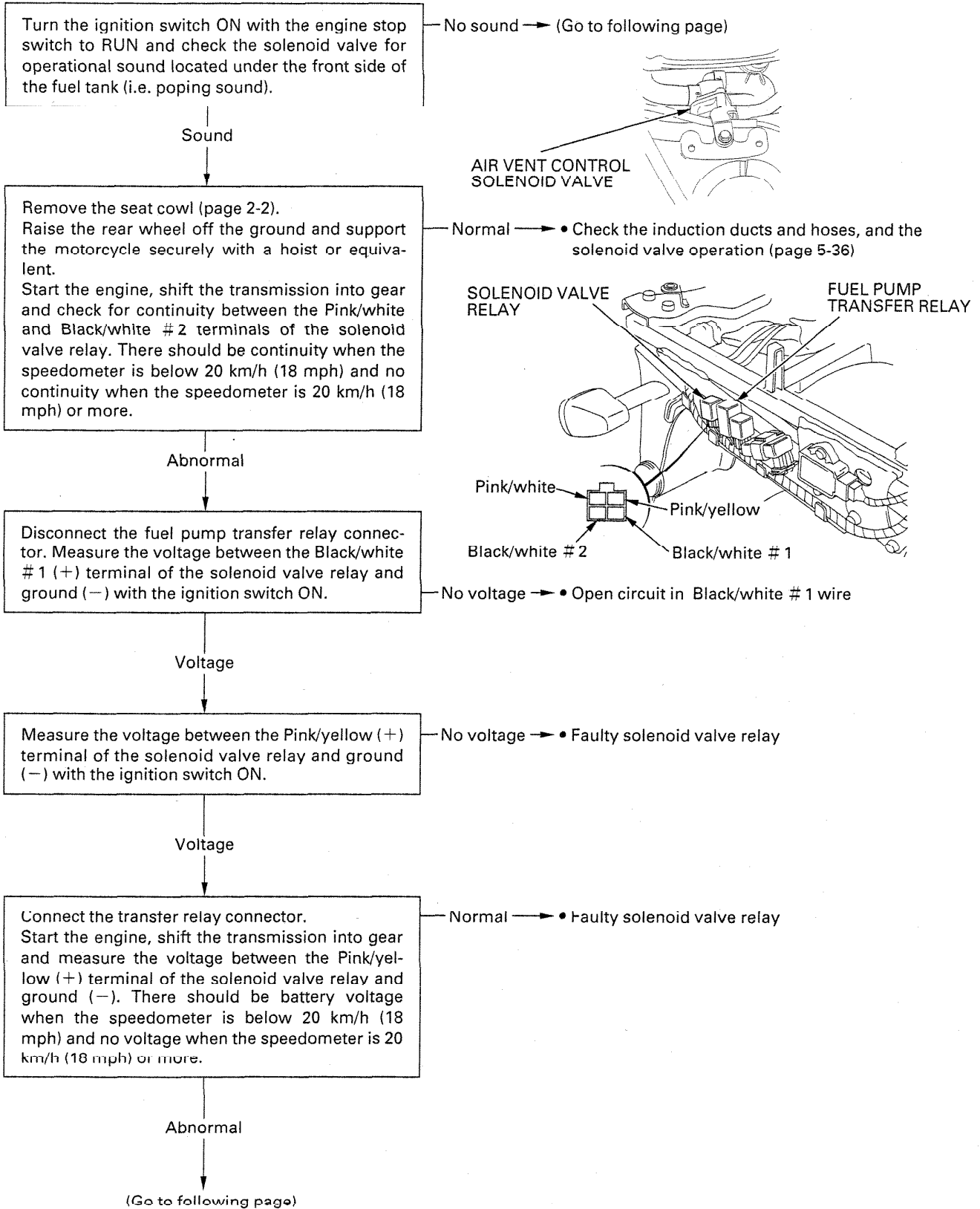

(From previous page: Abnormal)

Remove the combination meter without disconnecting the connector (page 19-6). Start the engine, shift the transmission into gear and measure the voltage between the Pink/yellow (+) and Green (-) terminals of the meter. There should be battery voltage when the speedometer is below 20 km/h (18 mph) and no voltage when the speedometer is 20 km/h (18 mph) or more.

Normal → • Open circuit in Pink/yellow wire

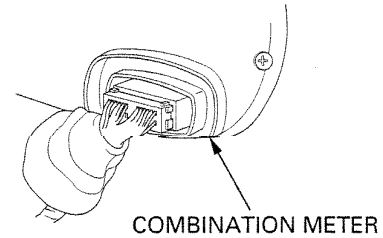

Abnormal

• Faulty combination meter

(From previous page: No sound)

Disconnect the solenoid valve 2P (Black) connector and measure the battery voltage between the Pink/white (+) and Green (-) terminals at the harness side connector with the ignition switch ON.

Voltage → • Check the solenoid valve operation (page 5-36)

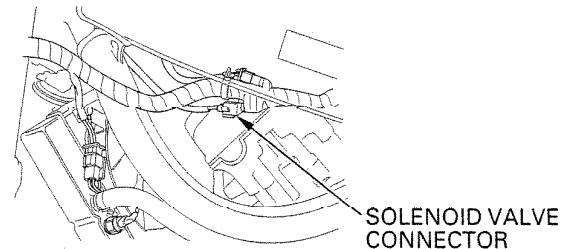

No voltage

Remove the seat cowl (page 2-2). Measure the voltage between the Black/white #2 (+) terminal of the solenoid valve relay and ground (-) with the ignition switch ON.

No voltage → • Open circuit in Black/white #2 wire

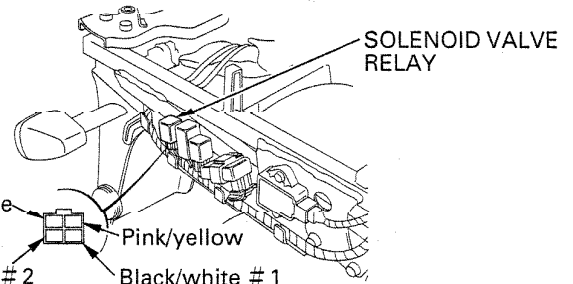

Voltage

Check for continuity between the Pink/white and Black/white #2 terminals of the solenoid valve relay with the ignition switch ON.

Continuity → • Open circuit in Pink/white or Green wire

No continuity

(Go to following page)

FUEL SYSTEM

(From previous page: No continuity)

Measure the voltage between the Black/white # 2 (+) and Pink/yellow (-) terminals of the solenoid valve relay with the ignition switch ON.

No voltage → • Faulty solenoid valve relay

Voltage

Disconnect the combination meter connector (page 19-6).
Check for continuity between the Pink/yellow terminal of the meter connector and ground.

Continuity → • Short circuit in Pink/yellow wire

No continuity

• Faulty combination meter

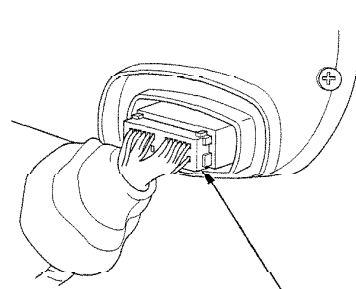

COMBINATION METER CONNECTOR

Direct Air Induction (D.A.I.) system malfunction (CALIFORNIA type)

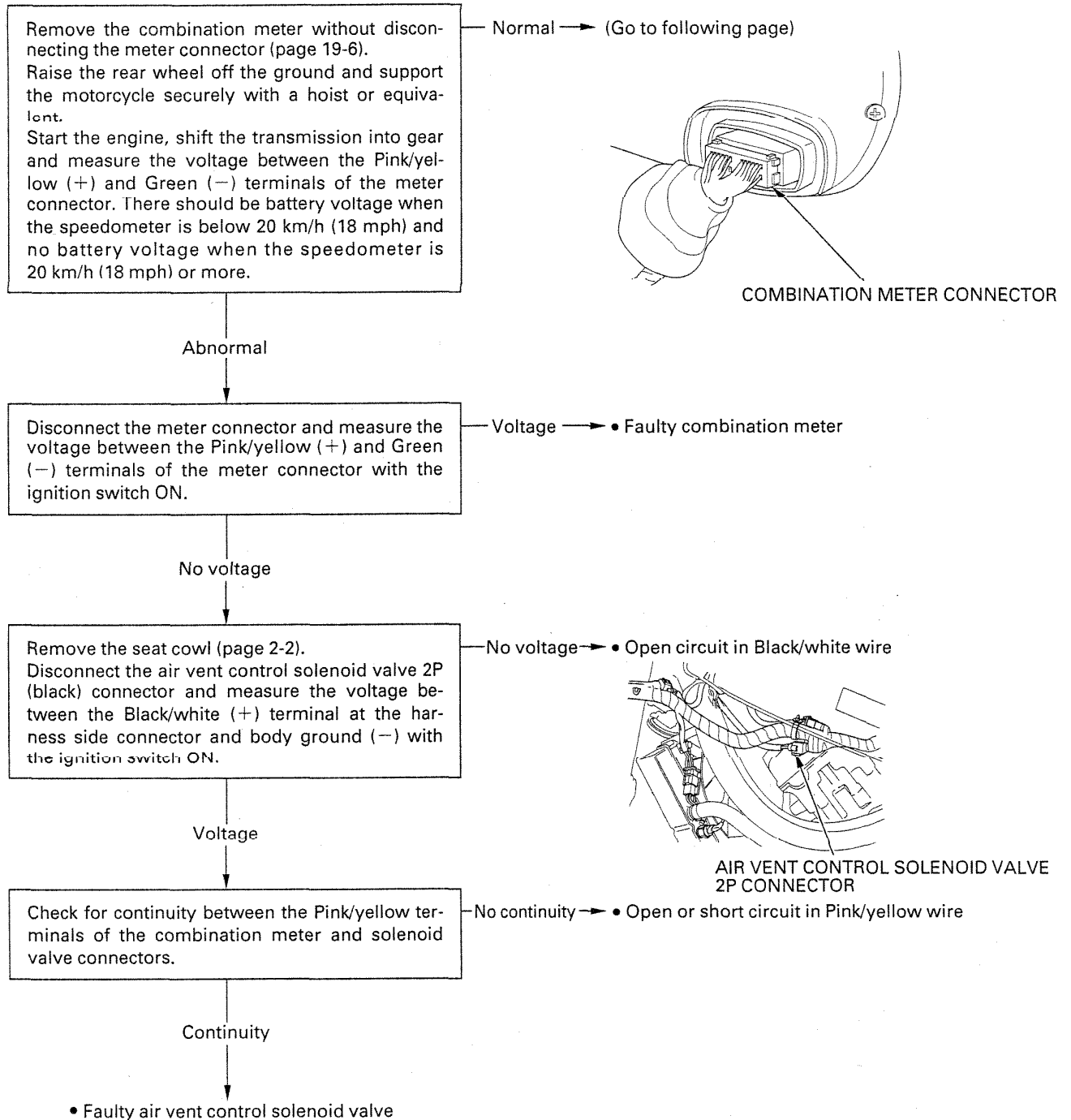

FUEL SYSTEM

(From previous page: Normal)

Disconnect the EVAP CAV solenoid valve 2P (black) connector.
Measure the voltage between the Black (+) and Green (-) terminals at the harness side connector with the ignition switch ON.

No voltage → • Open circuit in Black or Green wire

Voltage

- Check the induction ducts, hoses, and the air vent control solenoid valve and EVAP CAV solenoid valve operation (page 5-36 and 5-41)

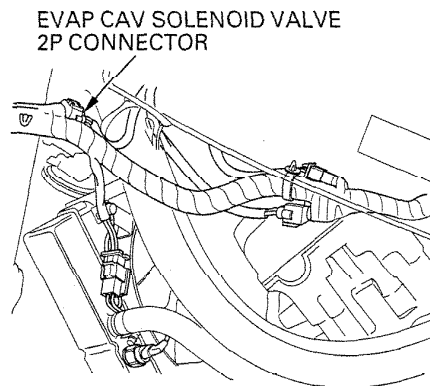

Fuel pump system malfunction

Remove the seat cowl (page 2-2).
 Raise the rear wheel off the ground and support the motorcycle securely with a hoist or equivalent.
 Start the engine, shift the transmission into gear and measure the voltage between the Pink/yellow (+) terminal of the fuel pump transfer relay and ground (-). There should be battery voltage when the speedometer is below 20 km/h (18 mph) and no voltage when the speedometer is 20 km/h (18 mph) or more.

Normal → (Go to following page)

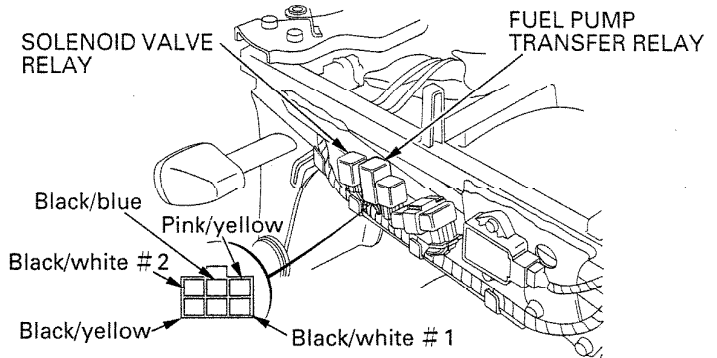

Abnormal

Measure the battery voltage between the Black/white #1 (+) terminal of the transfer relay and ground (-) with the ignition switch ON.

No voltage → • Open circuit in Black/white #1 wire

Voltage

Measure the battery voltage between the Pink/yellow (+) terminal of the transfer relay and ground (-) with the ignition switch ON.

Voltage → • Faulty fuel pump transfer relay

No voltage

Remove the combination meter without disconnecting the connector (page 19-6).
 Start the engine, shift the transmission into gear and measure the voltage between the Pink/yellow (+) and Green (-) terminals of the meter. There should be battery voltage when the speedometer is below 20 km/h (18 mph) and no voltage when the speedometer is 20 km/h (18 mph) or more.

Normal → • Open or short circuit in Pink/yellow wire

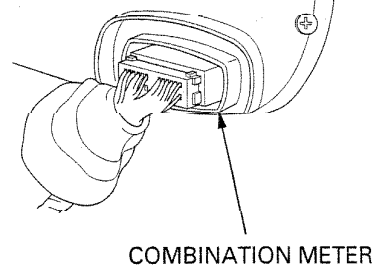

Abnormal

• Faulty combination meter

FUEL SYSTEM

(From previous page: Normal)

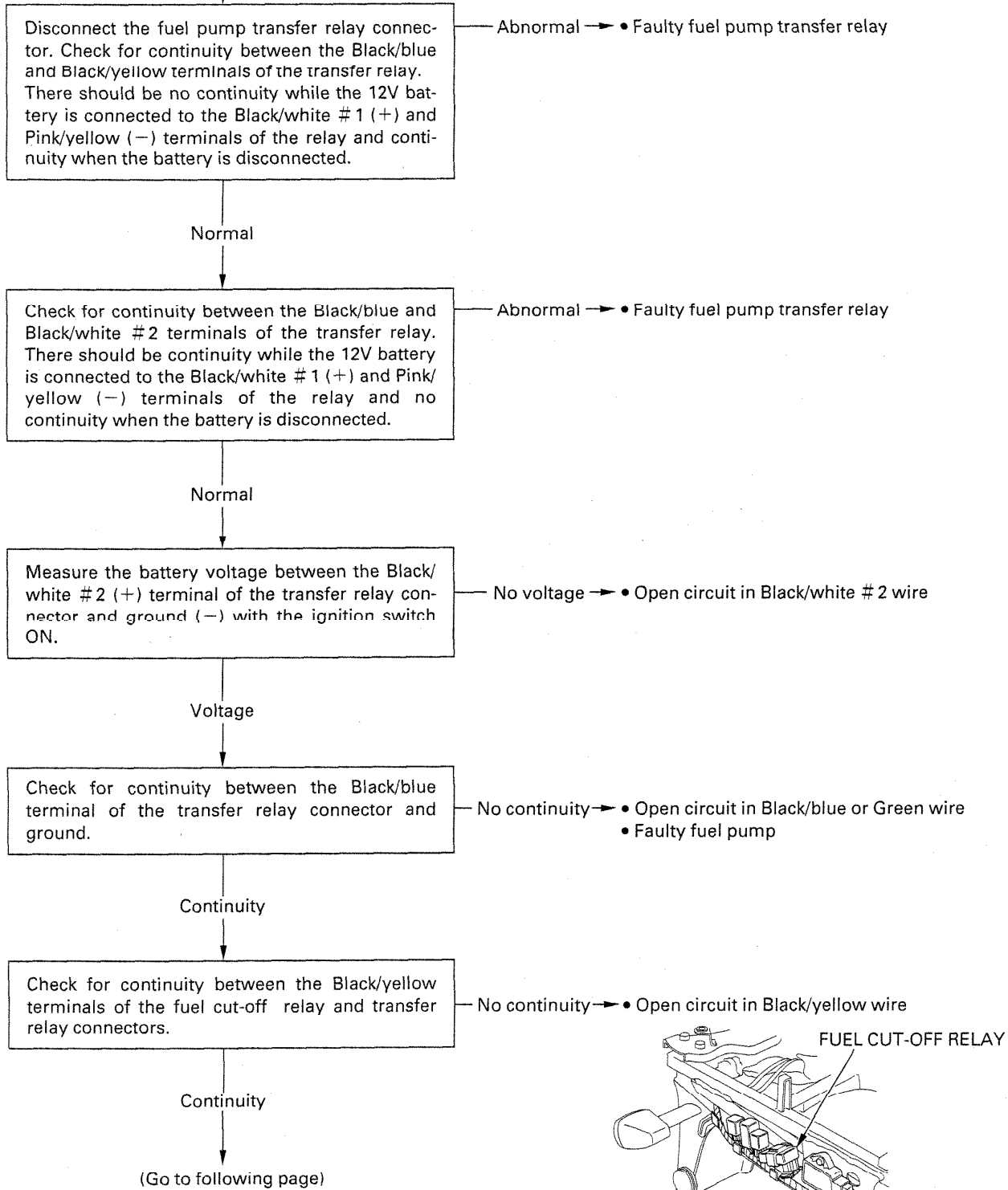

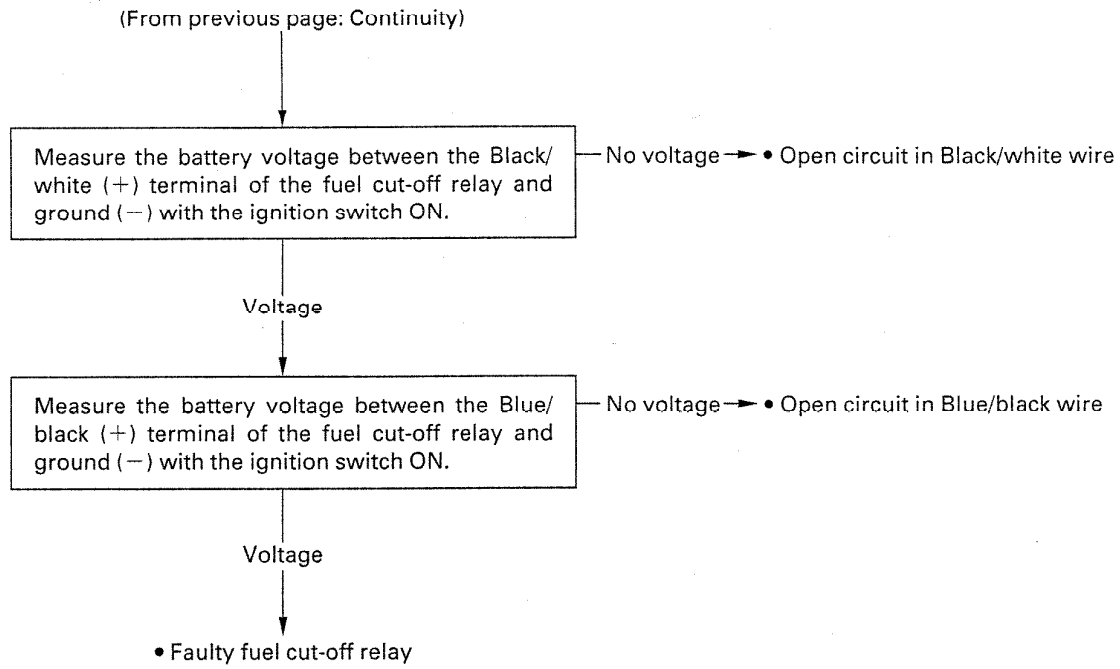

FUEL SYSTEM

AIR CLEANER HOUSING

REMOVAL/INSTALLATION

Remove the fuel tank (page 2-3).

California type only. Remove the evaporative emission (EVAP) purge control valve from the air cleaner housing.

Remove the wire harness clip from the air cleaner housing.

Be careful not to break the plastic plugs. Disconnect the four vacuum tubes and secondary air supply hose (California: No. 15).

Disconnect the crankcase breather hose from the air cleaner housing.
Loosen the two connecting tube band screws of the air intake ducts.

Loosen the four connecting tube hand screws.
Remove the air cleaner housing off the carburetor intake ports and air intake ducts.

Disconnect the float chamber inner air vent hose (California: No. 7) and the vacuum chamber air vent hose.

Installation is in the reverse order of removal.

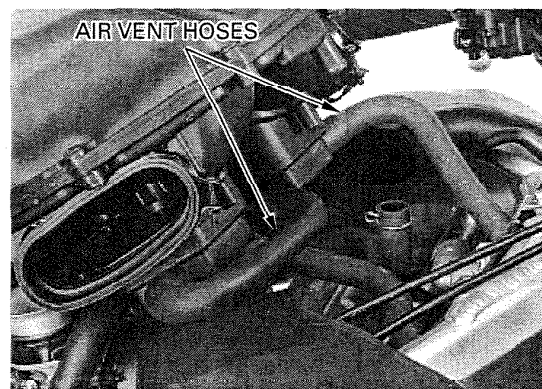
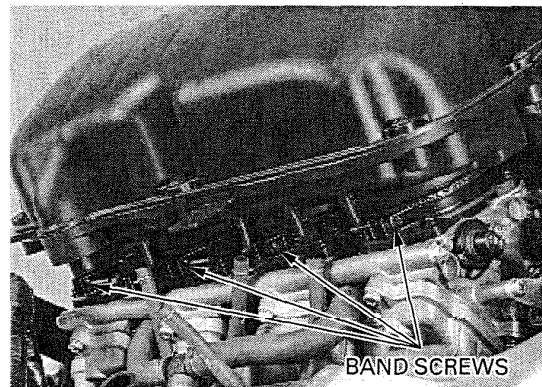
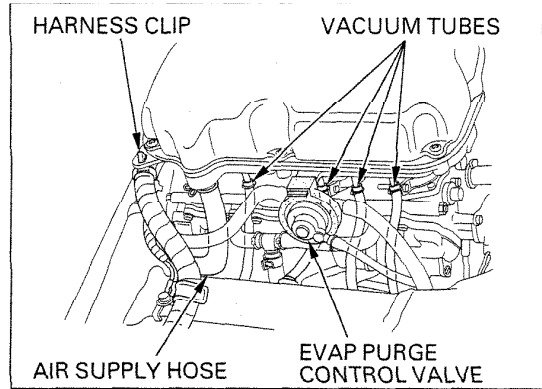

CARBURETOR REMOVAL

Drain the coolant (page 6-5).
Remove the air cleaner housing (page 5-14).

California type only: Disconnect the No. 11 tube.

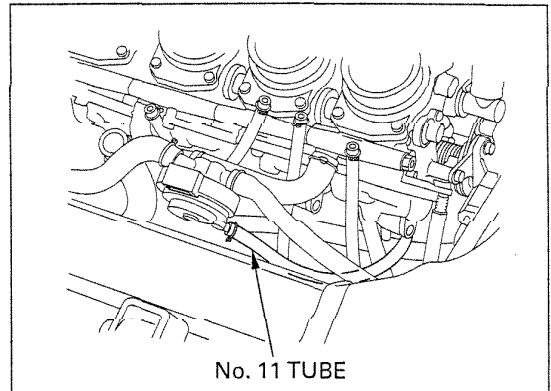

California type only: Disconnect the No. 5 tubes.

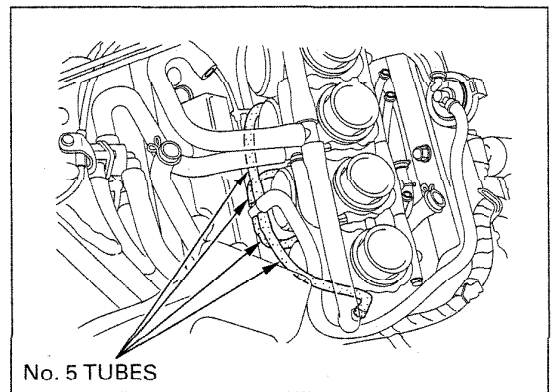

Disconnect the float chamber air vent hoses and the fuel tubes from the carburetor.

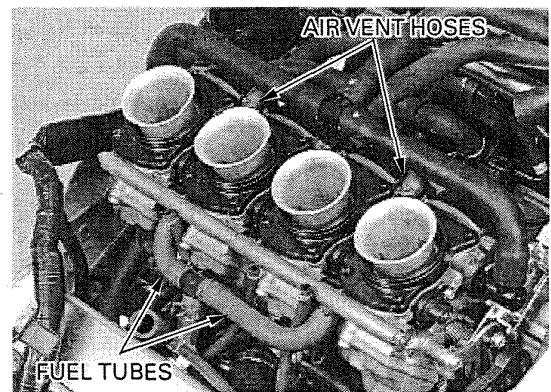

Remove the choke cable from the cable holder and disconnect it from the starting enrichment (SE) valve arm.

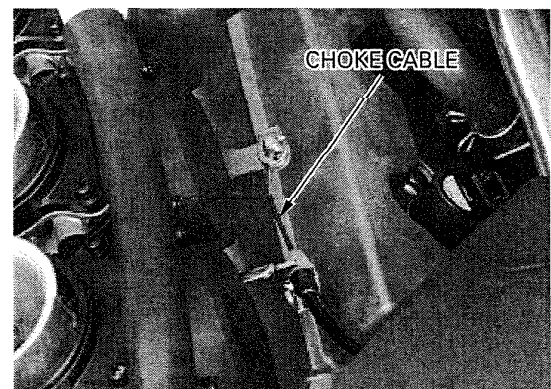

FUEL SYSTEM

Remove the throttle stop screw from the holder.

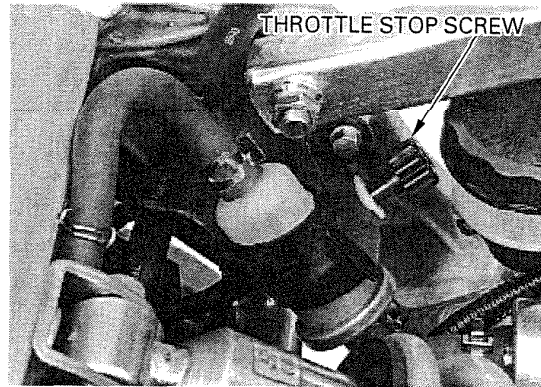

Loosen the four carburetor insulator band screws at the engine side, using a long screwdriver through the hole in both sides of the frame.

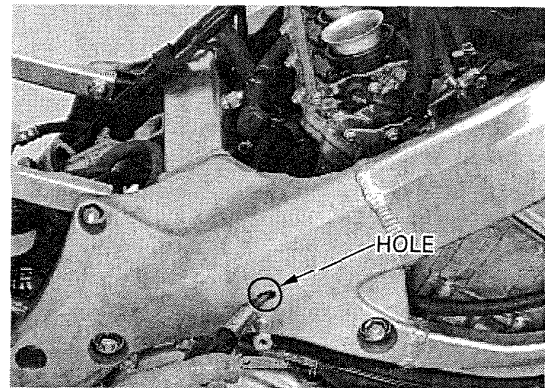

Place a clean shop towel over the intake ports to prevent any foreign material from dropping into the engine.

Remove the carburetor assembly off the cylinder head intake ports.

Disconnect the throttle sensor connector.

NOTE:

Do not remove the throttle sensor unless it is necessary to replace it or disassemble the carburetor. For sensor inspection and replacement, see page 17-7.

Loosen the throttle cable lock nuts, then remove the cables from the cable holder and disconnect them from the throttle drum.

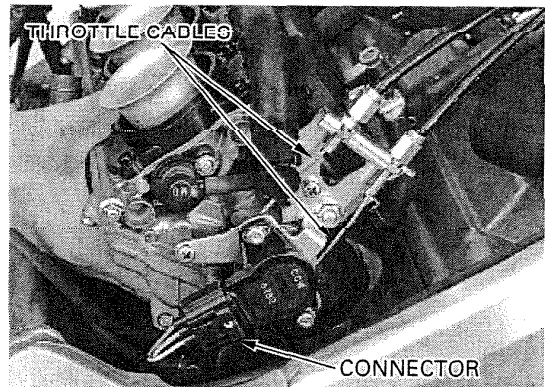

Disconnect the water tubes from the carburetor.

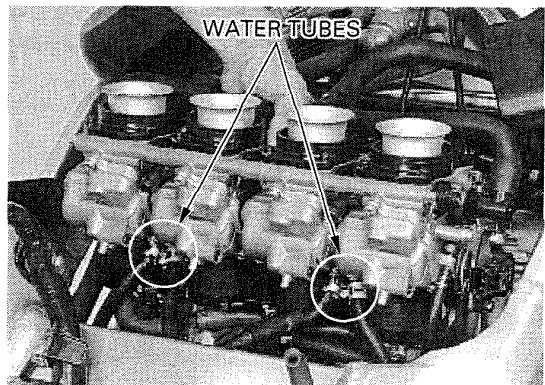

CARBURETOR SEPARATION

NOTE:

The vacuum chamber and float chamber can be serviced without separating the carburetors.

Remove the following:

- throttle stop screw with spring and washer
- carburetor insulators by loosening band screws
- two screws and washers
- SE valve arm and return spring
- two collars

- front connecting nut, screw and throttle sensor.

CAUTION:

Do not remove the throttle sensor from the bracket unless it requires replacement. It may cause the sensor to move out of position resulting in improper ignition timing.

- connecting nut, bolt and joint retainer
- air vent hose joint with O-ring

- screw and throttle cable holder (joint retainer)
- dowel pin
- air vent hose joint with O-ring.

Loosen the synchronization adjusting screws to reduce the spring tension and remove the synchronization springs.

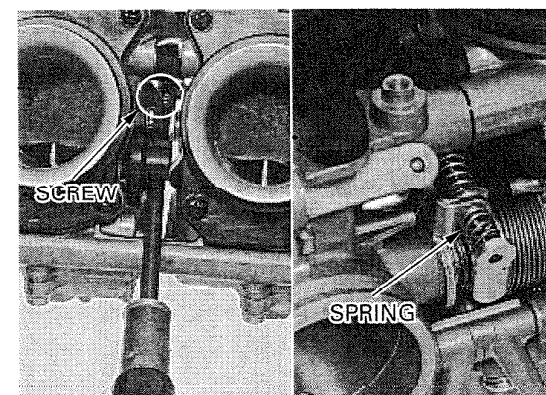
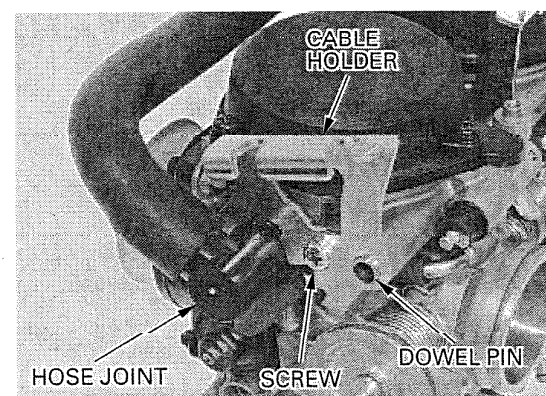
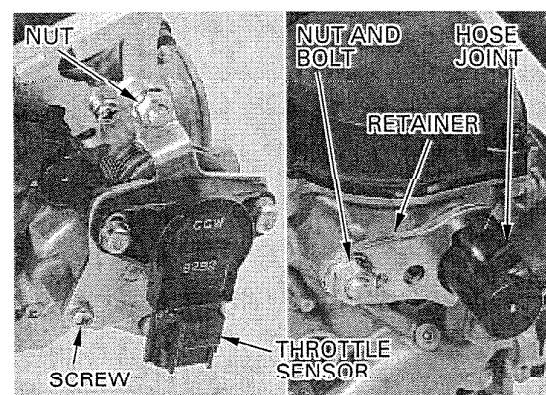
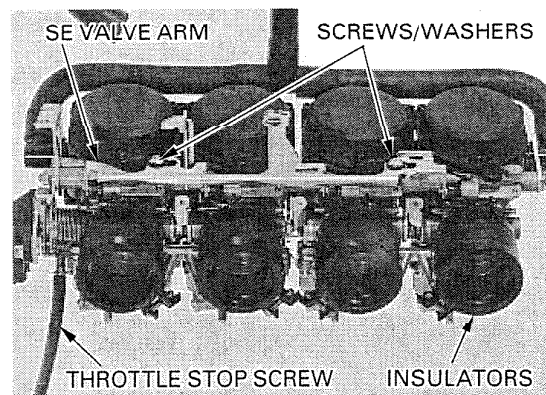

FUEL SYSTEM

Remove the rear connecting nuts and bolt.

Separate the No. 1/2 and No. 3/4 carburetors.

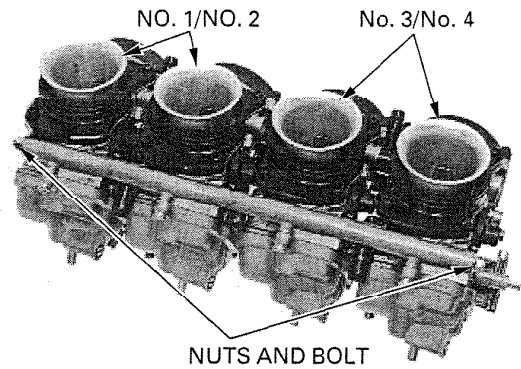

Remove the dowel pins.

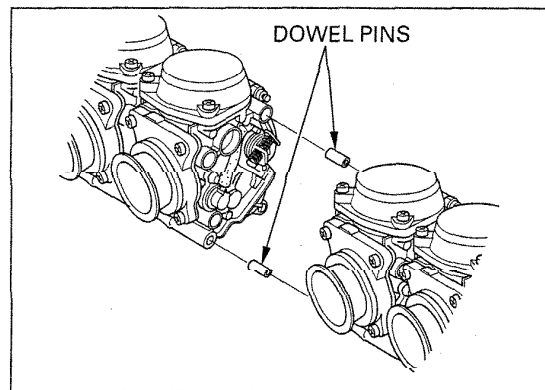

Refer to diagram on page 5-26 for identification of each component.

Separate the No. 1 and No. 2 carburetors then remove the thrust spring.

Remove the following:

- joint collar
- fuel tube joint
- air vent hose joint
- water tube joint
- dowel pins.

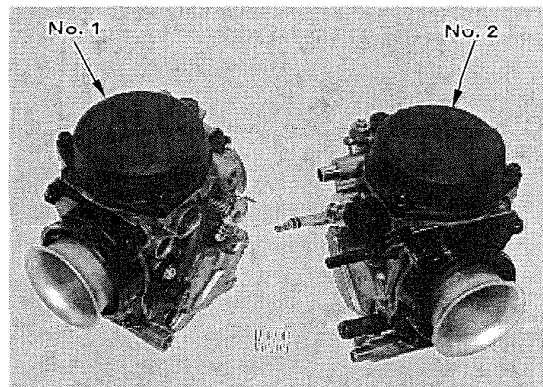

Separate the No. 3 and No. 4 carburetors then remove the thrust spring.

Remove the following:

- choke cable holder
- joint collar
- fuel tube joint
- air vent hose joint
- water tube joint
- dowel pins.

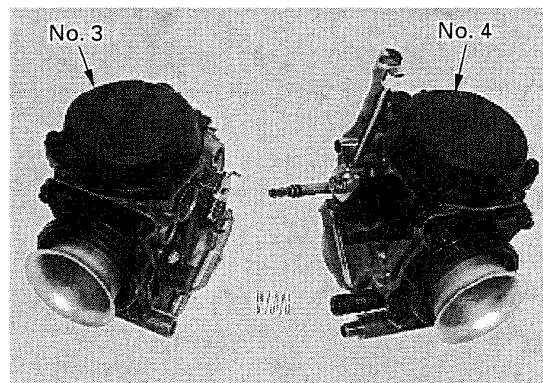

CARBURETOR DISASSEMBLY/ INSPECTION

AIR FUNNEL

Remove the following:

- four screws
- funnel holder
- air funnel
- O-ring.

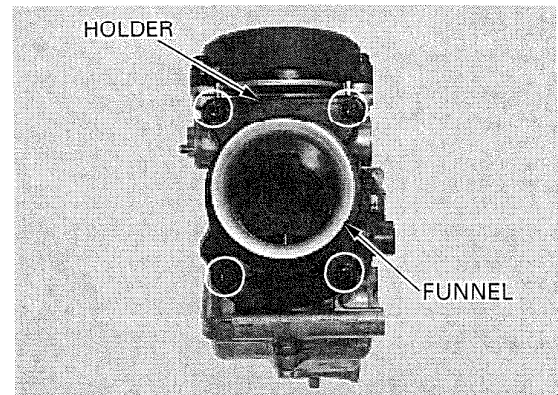

STARTING ENRICHMENT (SE) VALVE

Remove the following:

- valve nut
- valve spring
- SE valve.

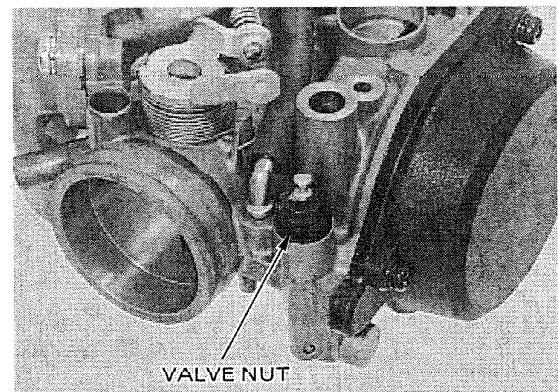

Check the SE valve for scoring, scratches or wear.
Check the seat at the tip of the SE valve for stepped wear.

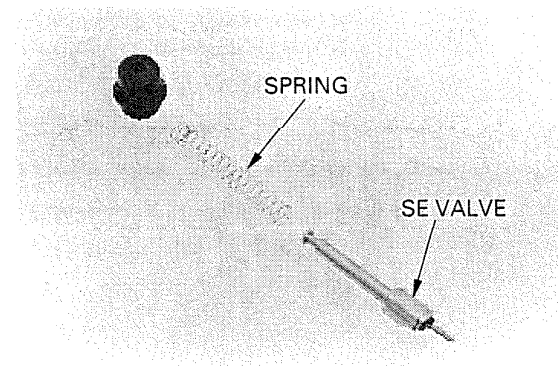

AIR CUT-OFF VALVE

Disconnect the vacuum tube from the vacuum pipe.
Remove the attaching screw and the air cut-off valve.

Remove the O-rings and joint pipe.

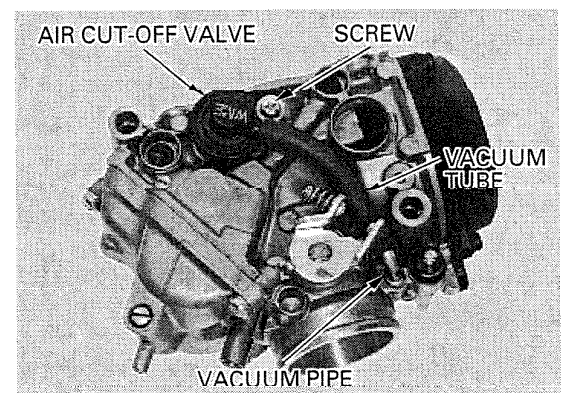

FUEL SYSTEM

Apply vacuum to the vacuum tube.

The vacuum should be maintained.
Air should not flow through the valve ports when the vacuum is applied, and should flow when the vacuum is not applied.

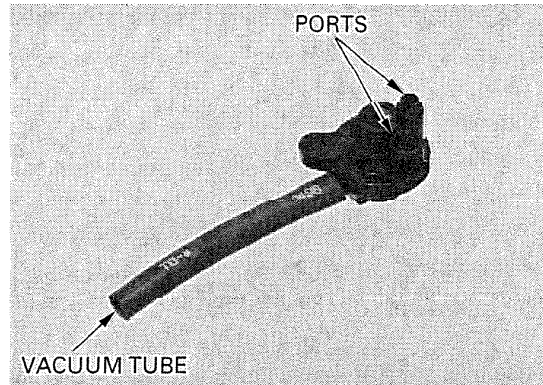

VACUUM CHAMBER

As the compression spring is very long, it will jump out of the carburetor when the cover is removed.

Remove the three screws and the vacuum chamber cover.

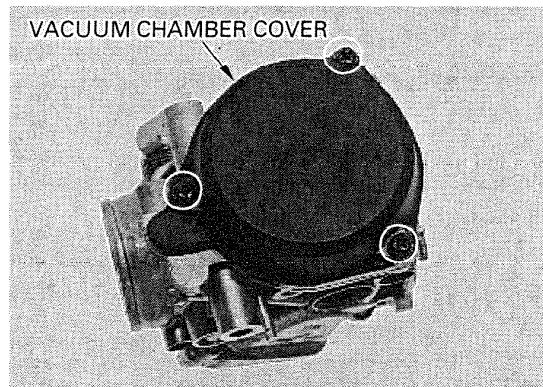

Remove the compression spring and diaphragm/vacuum piston from the carburetor body.

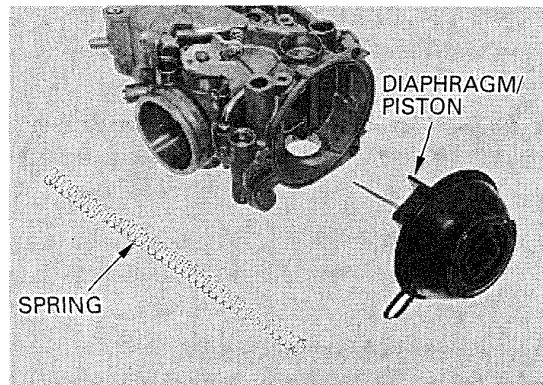

Be careful not to damage the diaphragm.

Screw one of the vacuum chamber cover (4 mm) screws into the jet needle holder. Pull the screw and remove the jet needle holder from the vacuum piston.

CAUTION:

Do not remove the jet needle holder by pushing the jet needle.

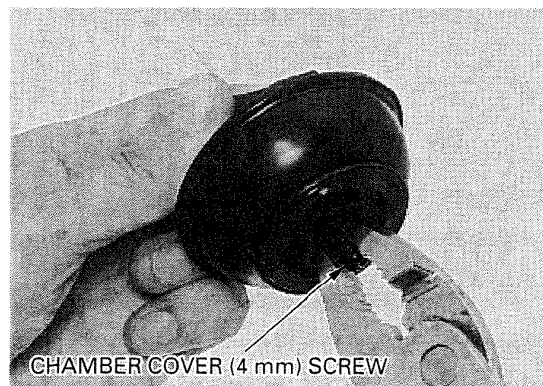

Remove the spring, jet needle and washer from the vacuum piston.

Check the jet needle for stepped wear.
Check the vacuum piston for wear or damage.
Check the diaphragm for pin hole, deterioration or damage.

NOTE:

Air leaks out of the vacuum chamber if the diaphragm is damaged in any way, even a pin hole.

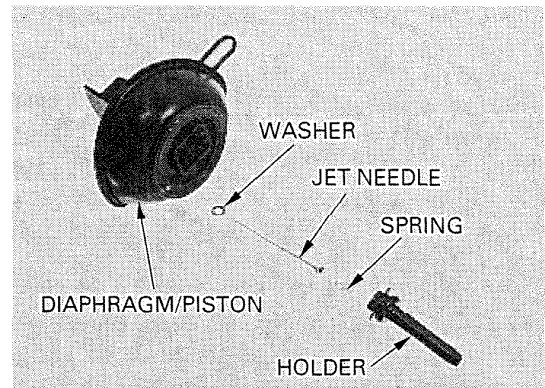

FLOAT CHAMBER

Remove the three screws and the float chamber.

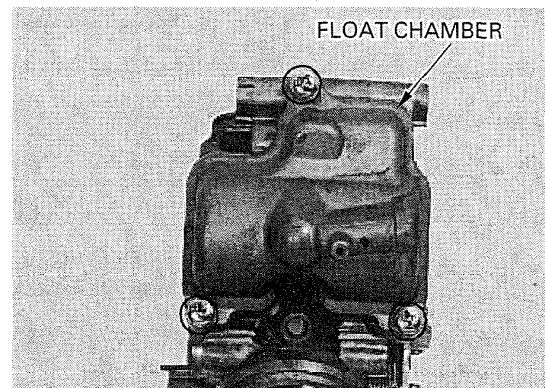

Remove the float pin, float and float valve.

Check the float for damage or fuel in the float.

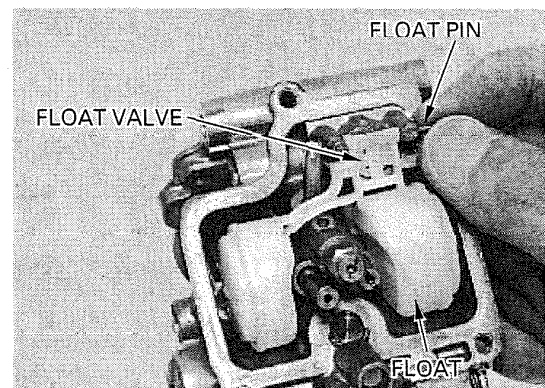

Check the float valve and valve seat for scoring, scratches, clogging or damage.
Check the tip of the float valve, where it contacts the valve seat, for stepped wear or contamination.
Check the operation of the float valve.

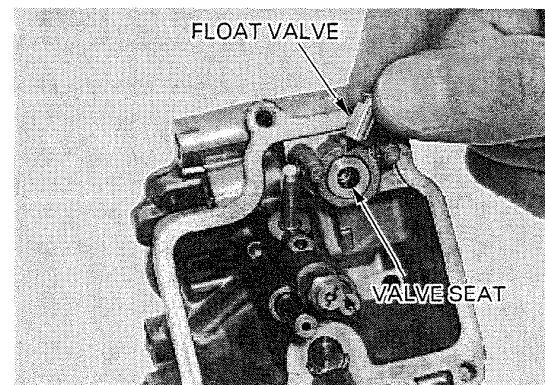

FUEL SYSTEM

Remove the main jet, needle jet holder and slow jet.

CAUTION:

Handle the jets with care. They can easily be scored or scratched.

Turn the pilot screw in and carefully count the number of turns until it seats lightly. Make a note of this to use as a reference when reinstalling the pilot screw.

TOOL:

Pilot screw wrench 07KMA-MN90100 or
 07KMA-MS60101

CAUTION:

Damage to the pilot screw seat will occur if the pilot screw is tightened against the seat.

Remove the pilot screw, spring, washer and O-ring.

Check each jet for wear or damage.
Check the pilot screw for wear or damage.

Clean the jets with cleaning solvent and blow open with compressed air.

CARBURETOR CLEANING

Remove the following:

- air funnel
- SE valve
- air cut-off valve
- diaphragm/vacuum piston.
- main jet, needle jet holder and slow jet.
- pilot screw.

CAUTION:

Cleaning the air and fuel passages with a piece of wire will damage the carburetor body.

Blow open all air and fuel passages in the carburetor body with compressed air.

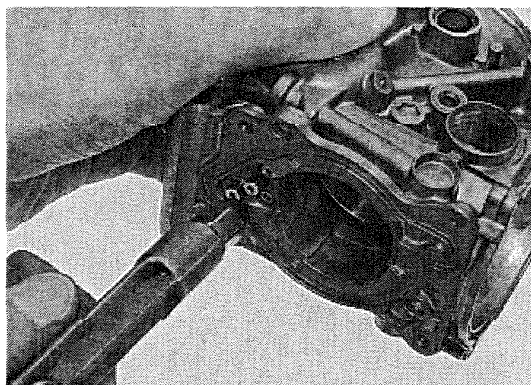
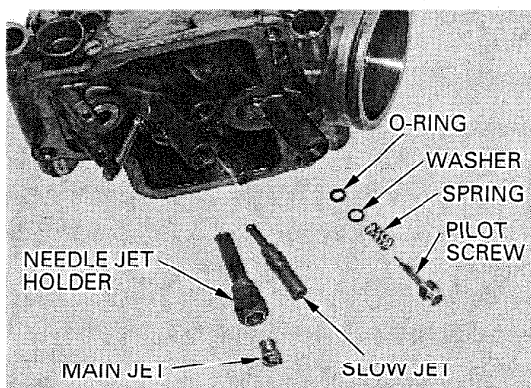
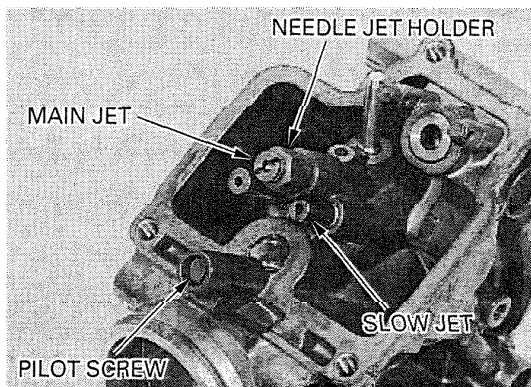

CARBURETOR ASSEMBLY

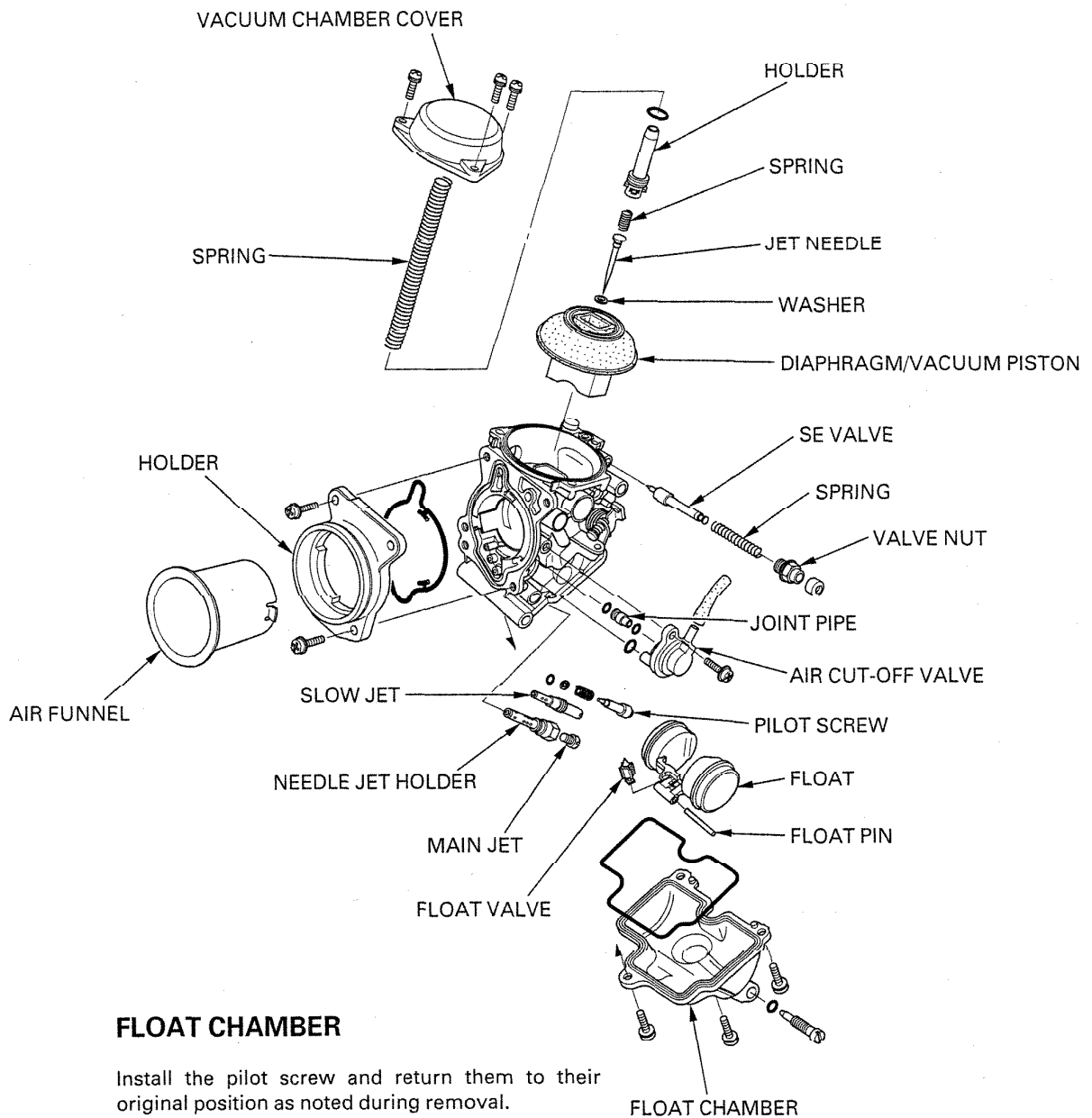

FLOAT CHAMBER

Install the pilot screw and return them to their original position as noted during removal.

TOOL:

Pilot screw wrench 07KMA-MN90100 or
 07KMA-MS60101

Perform the pilot screw adjustment if new pilot screw is installed.

CAUTION:

Damage to the pilot screw seat will occur if the pilot screw is tightened against the seat.

Install the needle jet holder, main jet and slow jet.

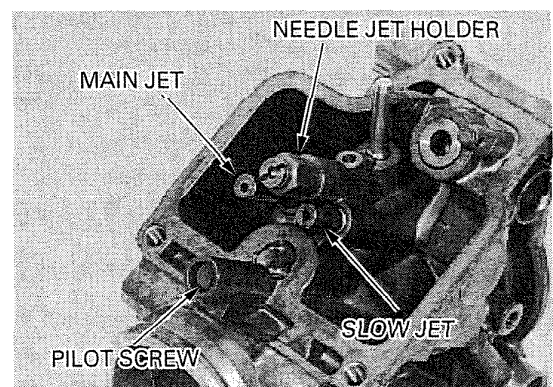

FUEL SYSTEM

CAUTION:

Handle the jets with care. They can easily be scored or scratched

Hang the float valve onto the float arm lip.
Install the float valve, float and float pin.

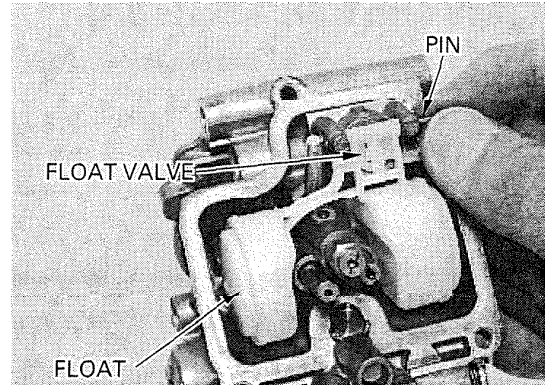

FLOAT LEVEL INSPECTION

NOTE:

Set the float level gauge that it is perpendicular to the float chamber face at the highest point of the float.

With the float valve seated and the float arm just touching the valve, measure the float level with the float level gauge.

TOOL:

Float level gauge 07401-0010000

FLOAT LEVEL: 13.7 + 0.5 mm (0.54 + 0.02 in)

The float cannot be adjusted.
Replace the float assembly if the float level is out of specification.

Install a new O-ring into the float chamber groove.
Install the float chamber and tighten the three screws.

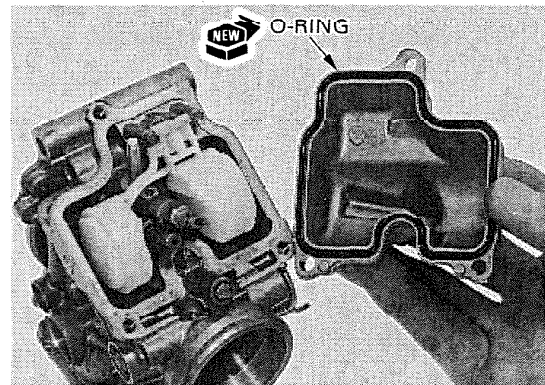
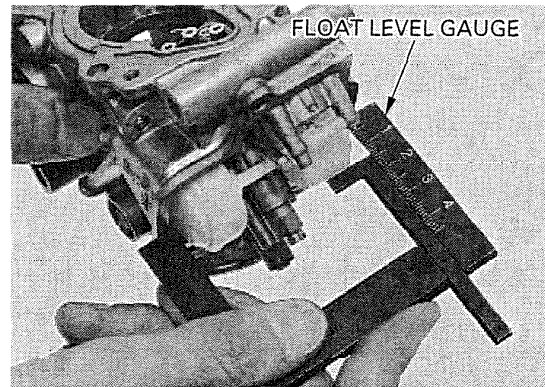

VACUUM CHAMBER

Coat a new O-ring with oil and install it into the holder groove, and the spring into the holder end hole.
Install the washer onto the jet needle.

Install the jet needle and needle holder into the vacuum piston.
Press the needle holder until you feel a click indicating that the O-ring is seated into the groove in the vacuum piston.

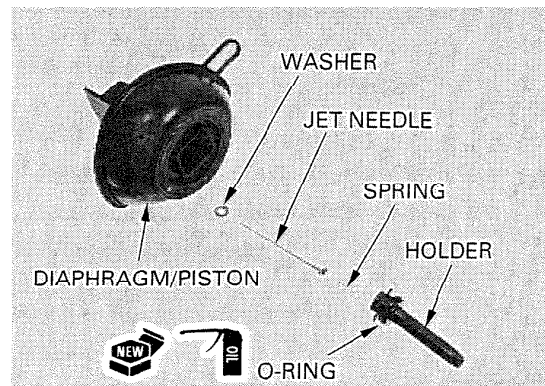

Install and compress the compression spring into the spring hole in the vacuum chamber cover using a screwdriver as a guide as shown.

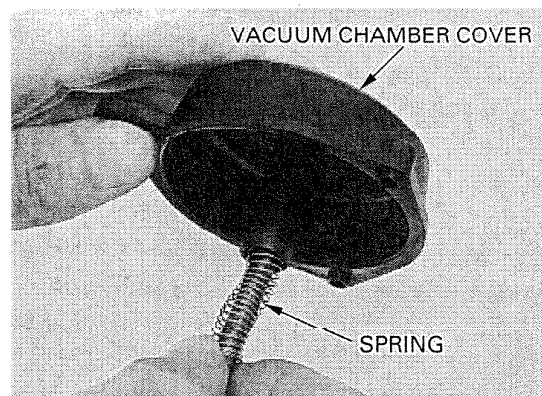

Be careful not to damage the jet needle. Install the diaphragm/vacuum piston into the carburetor body, then insert the jet needle into the needle jet. Lift the bottom of the piston with your finger to set the diaphragm rib into the groove in the carburetor body, and install the spring and vacuum chamber cover.

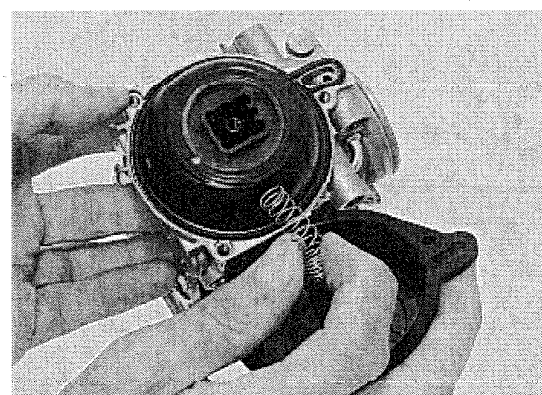

Be careful not to pinch the diaphragm under the chamber cover. Install and tighten the three screws.

AIR CUT-OFF VALVE

Install new O-rings onto the air cut-off valve and joint pipe. Install the joint pipe into the cut-off valve with the stepped side facing the air cut-off valve.

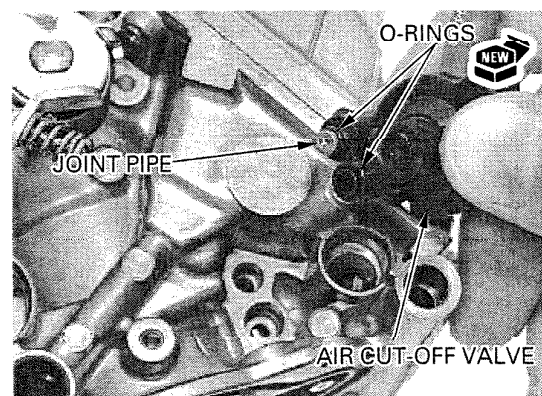

Install the air cut-off valve and secure it with the screw. Connect the vacuum tube to the vacuum pipe of the carburetor body.

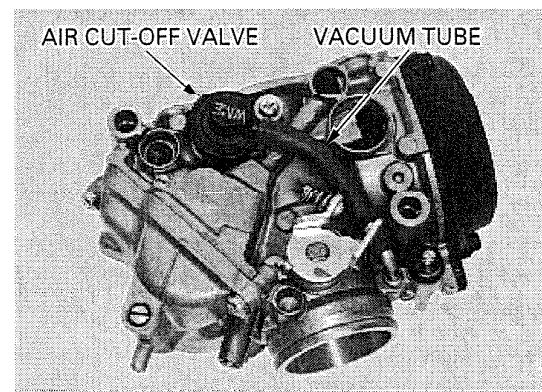

FUEL SYSTEM

SE VALVE

Install the spring over the SE valve and install it into the SE valve hole in the carburetor. Install the valve nut and tighten it.

TORQUE: 2 N·m (0.2 kgf·m , 1.4 lbf·ft)

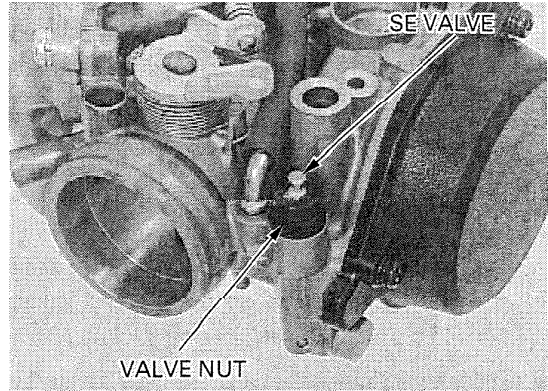

AIR FUNNEL

Install a new O-ring into the groove in the carburetor body.

Set the air funnel through the funnel holder as shown and install them by aligning the cut-outs in the funnel with the lugs of the carburetor body. Install the four screws and tighten them.

Be careful not to pinch the O-ring.

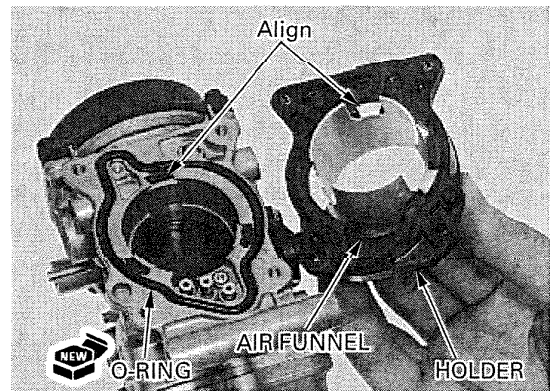

CARBURETOR COMBINATION

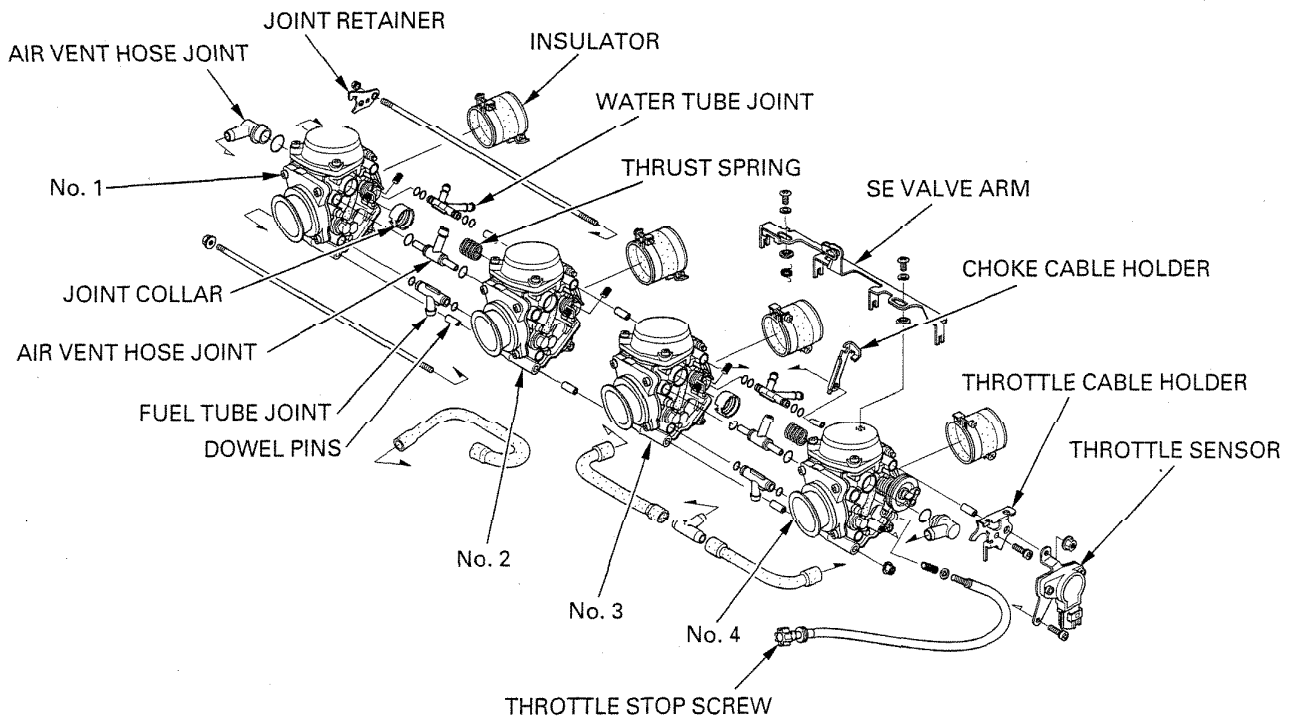

NOTE:

- Always replace the O-rings with new ones and coat them with oil.
- Apply grease to the synchronization adjusting screw tips.

No. 3 and No. 4 carburetors:

Install the following onto the carburetor:

- dowel pins
- water tube joint with new O-rings
- air vent hose joint with new O-rings
- fuel tube joint with new O-rings
- joint collar
- choke cable holder, aligning groove with stopper
- thrust spring (place over the synchronization nut)

Assemble the No. 3 and No. 4 carburetors.

Install the synchronization spring.

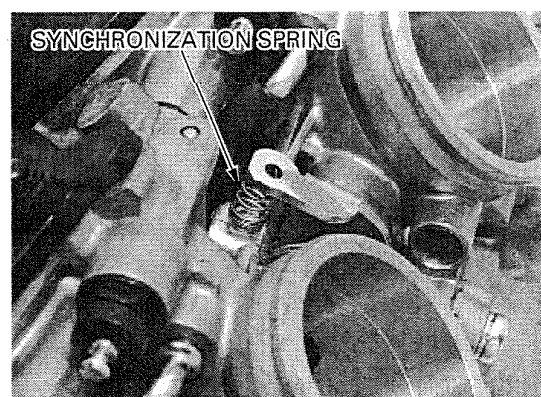
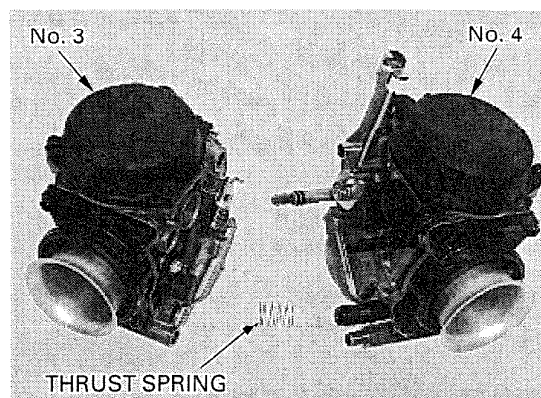

No. 1 and No. 2 carburetors:

Install the following onto the carburetor:

- dowel pins
- water tube joint with new O-rings
- air vent hose joint with new O-rings
- fuel tube joint with new O-rings
- joint collar
- thrust spring (place over the synchronization nut)

Assemble the No. 1 and No. 2 carburetors.

Install the synchronization spring.

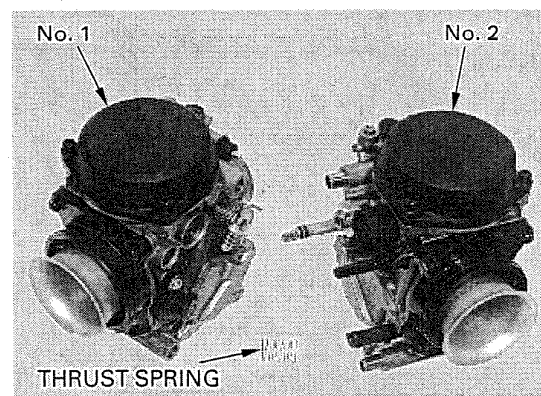

No. 1/2 and No. 3/4 carburetors:

Install the dowel pins onto the carburetor.

Assemble the No. 1/2 and No. 3/4 carburetors.

Install the synchronization spring.

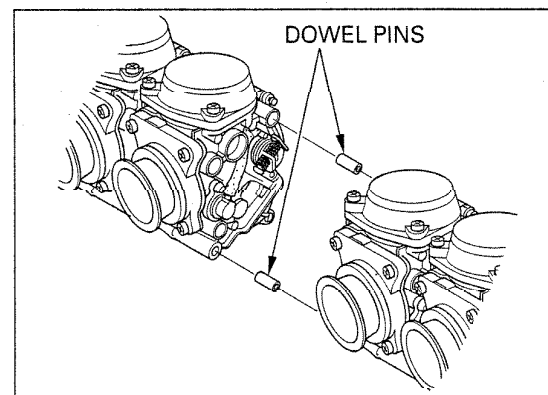

FUEL SYSTEM

Be sure there is no clearance at the joint area of the carburetor bodies.

Install the rear connecting bolt and nuts, and temporarily tighten them.

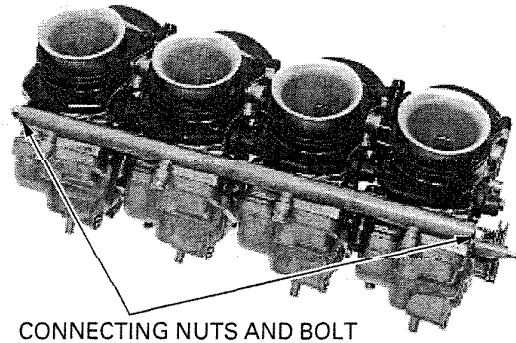

Install new O-rings into the tube joint grooves. Install the air vent hose joints into the carburetors.

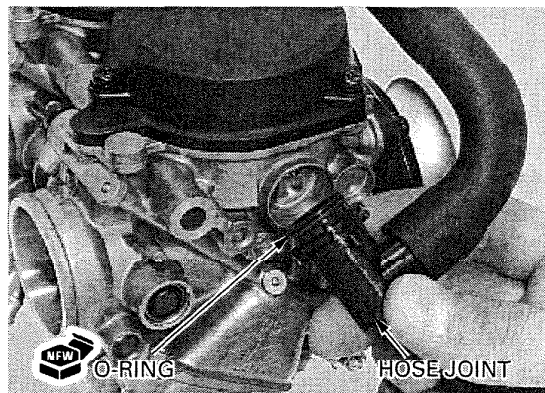

Install the dowel pin. Install the throttle cable holder (joint retainer), aligning its groove with the joint lug and secure it with the screw.

Install the connecting bolt, nut and tube joint retainer, aligning the retainer groove with the joint lug.

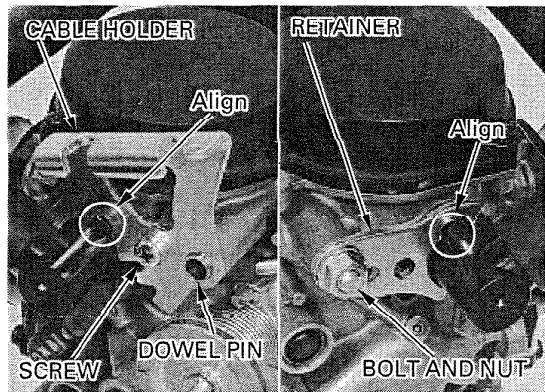

Install the throttle sensor by aligning the tabs of the throttle sensor with the flat of the shaft as shown. Install the nut and screw.

CAUTION:

Install the throttle sensor properly. Improper installation can cause damage to the throttle sensor.

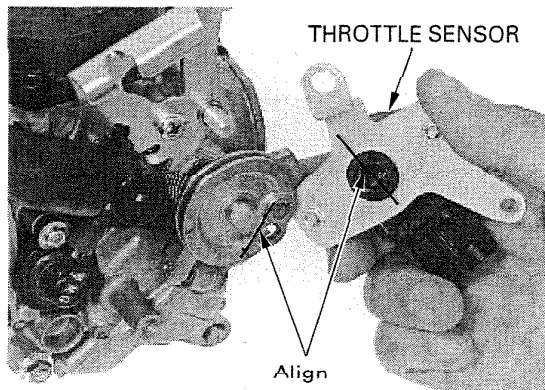

Tighten the each connecting nuts gradually and alternately, be sure the bolt threads projections are equal height (within 0–3 mm).
Hold the nut and tighten the nut on other side.

TORQUE: 6 mm nut: 9 N·m (0.9 kgf·m , 6.5 lbf·ft)
5 mm nut: 5 N·m (0.5 kgf·m , 3.6 lbf·ft)

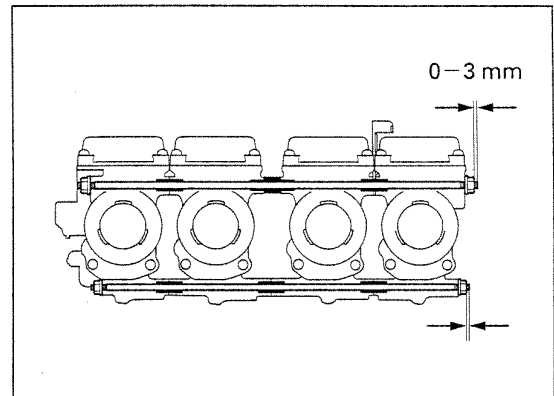

Install the arm return spring over the boss on the No. 2 carburetor.
Install the plastic collars onto the SE valve arm bosses of the carburetors.
Install the SE valve arm over the SE valves and onto the carburetors and attach the return spring.
Install the plastic washers and screws and tighten them.

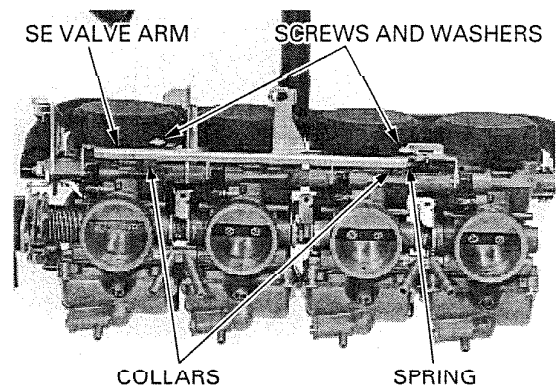

Install the throttle stop screw with the washer and spring.

Turn the throttle stop screw to align the throttle valve with the edge of the outside by-pass hole in the No. 4 carburetor.

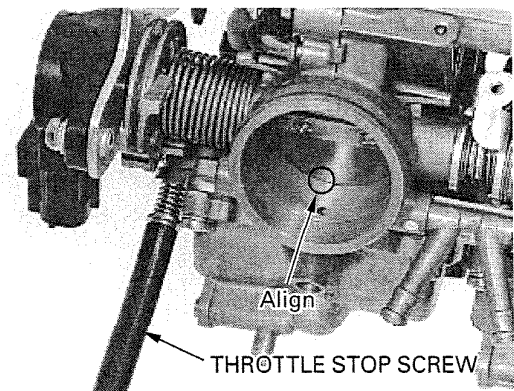

Align each carburetor (No. 1, No. 2 and No. 3) throttle valve with the outside by-pass hole by turning the synchronization adjusting screw.

Rotate the throttle drum and be sure that each throttle valve opens and closes smoothly.

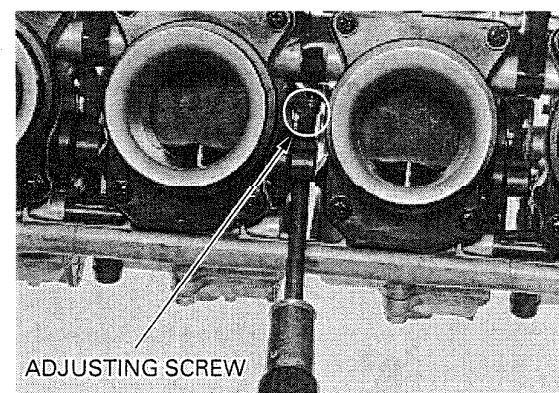

FUEL SYSTEM

Install the carburetor insulators with the "CARB" mark facing the carburetor and the band screw heads facing the outside as shown.

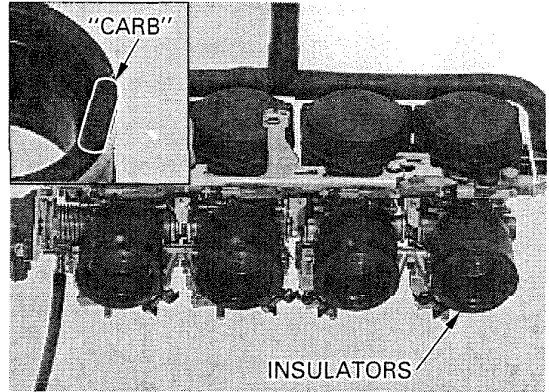

Align each insulator groove with each carburetor lug to seat the insulators securely.

Align the band hole with the insulator boss. Tighten each band screw until the clearance between the band ends is 11–13 mm (0.4–0.5 in).

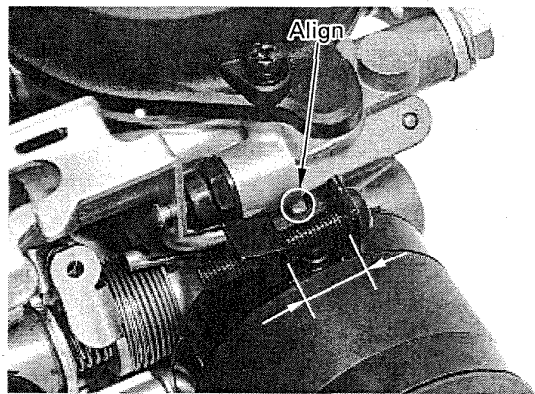

CARBURETOR INSTALLATION

NOTE:

Route the tubes and cables properly (page 1-18).

Connect the water tubes to the carburetor.

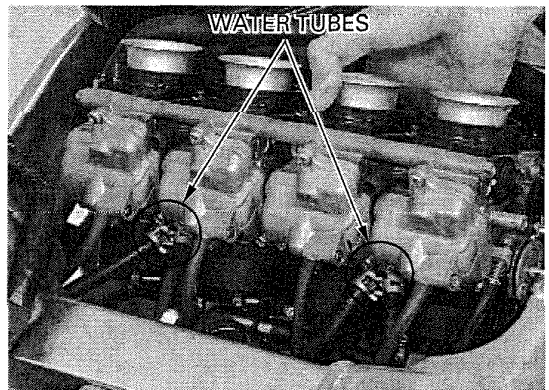

Connect the throttle cables to the throttle drum and install them into the cable holder.

Connect the throttle sensor connector.

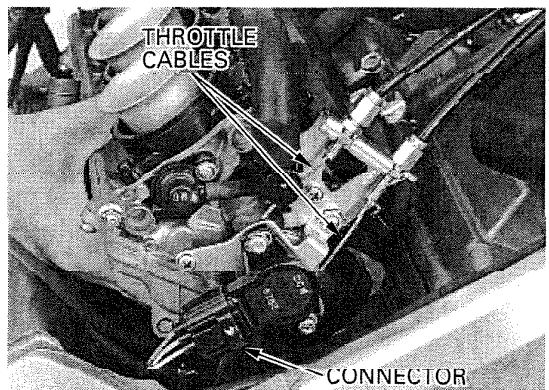

Install the carburetor assembly over the intake ports by pressing the assembly against the cylinder head surface securely.

Insert the screwdriver through the hole in both sides of the frame and tighten the insulator band screws as shown.

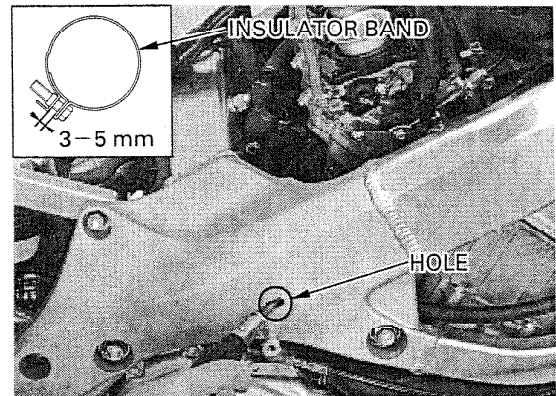

Install the throttle stop screw into the cable holder.

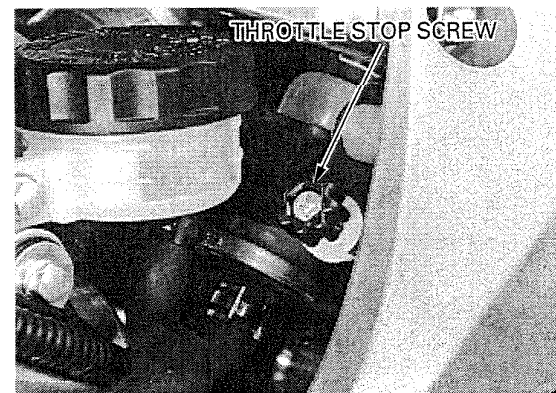

Connect the choke cable to the SE valve arm and install it into the cable holder.

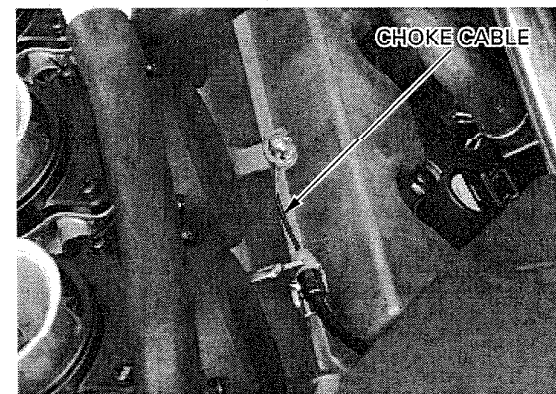

Connect the fuel tubes and the float chamber air vent hoses.

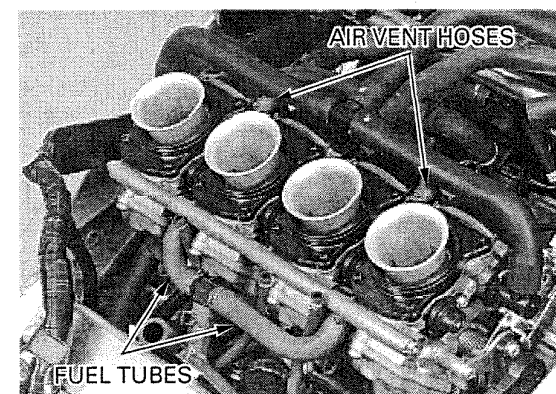

FUEL SYSTEM

California type only: Connect the No. 5 tubes.

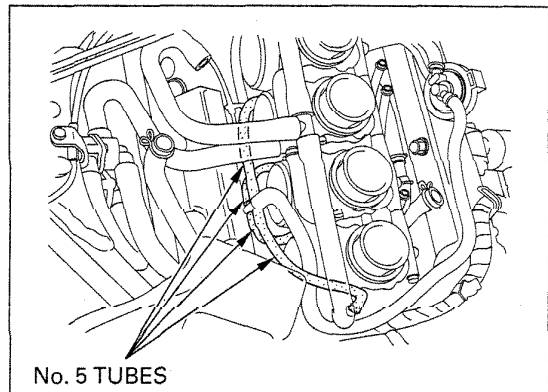

California type only: Connect the No. 11 tube.

Perform the following inspections and adjustment:
— Throttle operation (page 3-4)
— Carburetor choke (page 3-5).

Install the air cleaner housing (page 5-14).
Fill and bleed the cooling system (page 6-4).

Adjust the carburetor synchronization if the carburetors were disassembled (page 3-13).

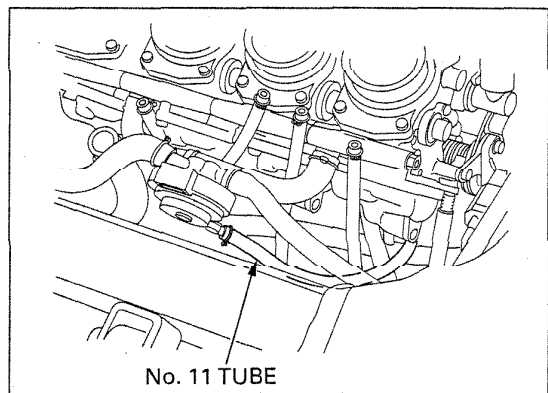

PILOT SCREW ADJUSTMENT

IDLE DROP PROCEDURE

NOTE:

- Make sure the carburetor synchronization is within specification before pilot screw adjustment.
- The pilot screws are factory pre-set and no adjustment is necessary unless the pilot screws are replaced.
- Use a tachometer with graduations of 50 rpm or smaller that will accurately indicate a 50 rpm change.

1. Raise the fuel tank and support it (page 2-3). Turn each pilot screw clockwise until it seats lightly, then back it out to the specification given. This is an initial setting prior to the final pilot screw adjustment.

CAUTION:

Damage to the pilot screw seat will occur if the pilot screw is tightened against the seat.

TOOL:

Pilot screw wrench 07KMA-MN90100 or
 07KMA-MS60101

INITIAL OPENING:

49 state/Canada type: 3-1/8 turns out
California type: 2-3/8 turns out

2. Warm up the engine to operating temperature. Stop and go driving for 10 minutes is sufficient.
3. Stop the engine and connect a tachometer according to the tachometer manufacturer's instructions.
4. Start the engine and adjust the idle speed with the throttle stop screw.

IDLE SPEED:

49 state/Canada type: 1,300 ± 100 rpm
California type: 1,400 ± 100 rpm

5. Turn the No. 4 carburetor pilot screw in or out slowly to obtain the highest engine speed.
6. Perform step 5 for all carburetor pilot screws.
7. Lightly open the throttle 2 or 3 times, then adjust the idle speed with the throttle stop screw.
8. Turn the No. 4 carburetor pilot screw in until the engine speed drops by 50 rpm.
9. Turn the No. 4 carburetor pilot screw out to the final opening from the position obtained in step 8.

FINAL OPENING:

49 state/Canada type: 3/4 turns out
California type: 1 turns out

10. Adjust the idle speed with the throttle stop screw.
11. Perform steps 8, 9 and 10 for all carburetor pilot screws.

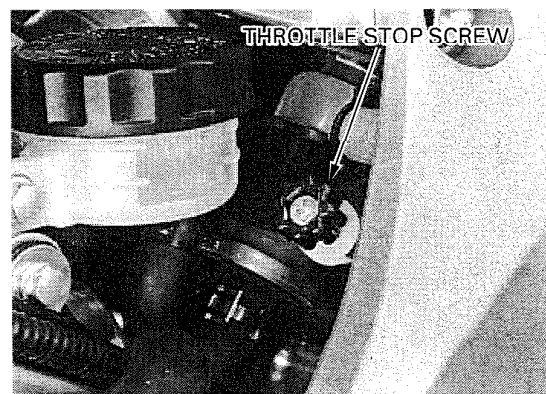
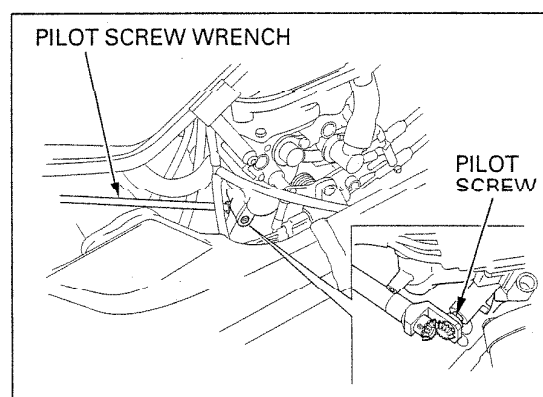

FUEL SYSTEM

HIGH ALTITUDE ADJUSTMENT

When the vehicle is to be operated continuously above 2,000 m (6,500 feet), the carburetors must be readjusted as described below to improve driveability and decrease exhaust emissions.

Remove the carburetor assembly from the intake ports of the cylinder head (page 5-15).
Drain the carburetors and remove the float chambers.
Change each main jet for a high altitude one.

HIGH ALTITUDE MAIN JET

49 state/Canada type:

No. 1 and 4 carburetors: # 130

No. 2 and 3 carburetors: # 132

California type: # 125

Install the float chambers.
Install the carburetor assembly (page 5-30).
Install the fuel tank and support it with the eye-let wrench (page 2-3).

Warm up the engine to operating temperature.
Stop and go driving for 10 minutes is sufficient.
Turn each pilot screw in to the specification given.

TOOL:

Pilot screw wrench 07KMA-MN90100 or
07KMA-MS60101

HIGH ALTITUDE SETTING: 1/2 turn in

Adjust the idle speed with the throttle stop screw.

IDLE SPEED.

49 state/Canada type: 1,300 ± 100 rpm

California type: 1,400 ± 100 rpm

Attach the Vehicle Emission Control Information Update label on the rear fender under the seat as shown.

NOTE:

Do not attach the label to any part that can be easily removed from the vehicle.

CAUTION:

Sustained operation at an altitude lower than 1,500 m (5,000 feet) with the carburetors adjusted for high altitude may cause the engine to idle roughly and the engine to stall in traffic. It may also cause engine damage due to overheating.

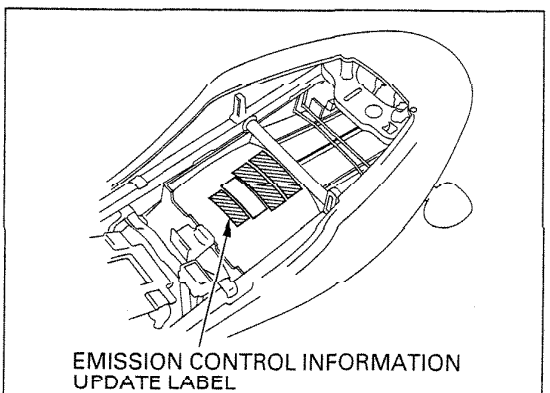
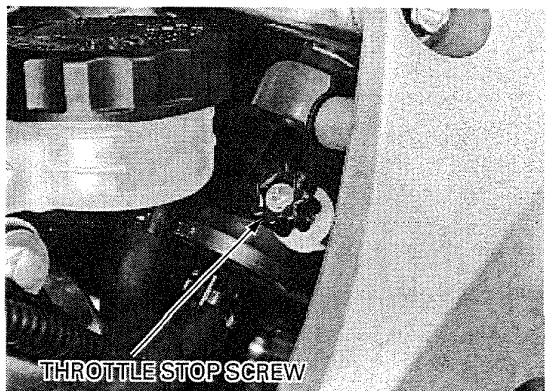
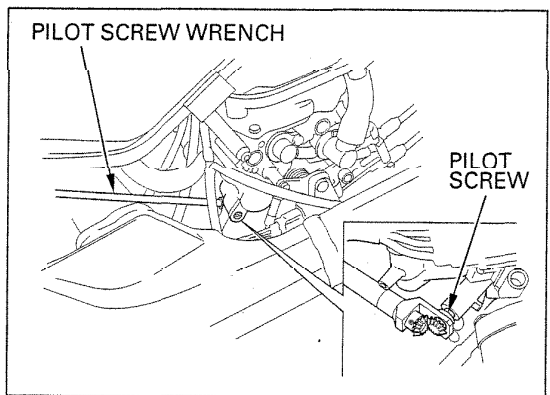
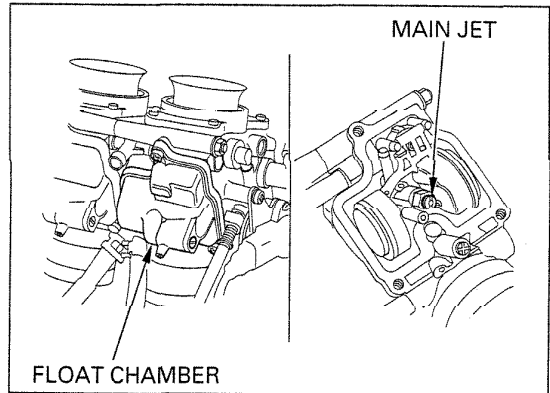

These adjustments must be made at low altitude to ensure proper low altitude operation.

When the vehicle is to be operated continuously below 1,500 m (5,000 feet), readjust the carburetors as follows:

Change each main jet for the standard one.

STANDARD MAIN JET:

49 state/Canada type:

No. 1 and 4 carburetors: # 132

No. 2 and 3 carburetors: # 135

California type: # 128 (all carburetors)

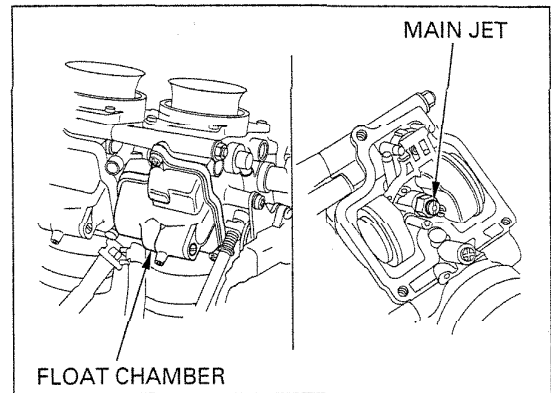

Warm up the engine to operating temperature. Stop and go driving for 10 minutes is sufficient. Turn each pilot screw out 1/2 turn to its original position.

TOOL:

Pilot screw wrench

07KMA-MN90100 or

07KMA-MS60101

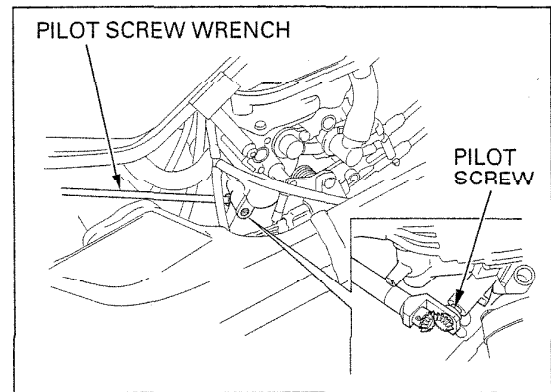

Adjust the idle speed with the throttle stop screw.

IDLE SPEED:

49 state/Canada type: 1,300 ± 100 rpm

California type: 1,400 ± 100 rpm

NOTE:

These adjustments must be made at low altitude to ensure proper low altitude operation.

Remove the Vehicle Emission Control Information Update label that is attached to the rear fender under the seat after adjusting for low altitude.

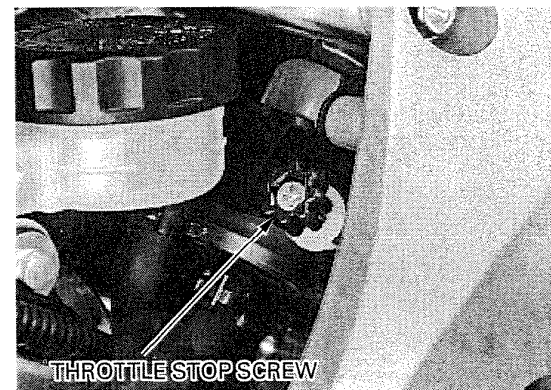

FUEL SYSTEM

DIRECT AIR INDUCTION (D.A.I.) SYSTEM

AIR VENT CONTROL SOLENOID VALVE INSPECTION

Raise the fuel tank and support it (page 2-3).
Check the Induction ducts and connecting tubes for damage or loose connection.

Remove the air cleaner housing (page 5-14).
Remove the front fairing (page 2-5).
Check the induction hoses for deterioration, damage or loose connections.
Check the sub-air cleaner for clogging.

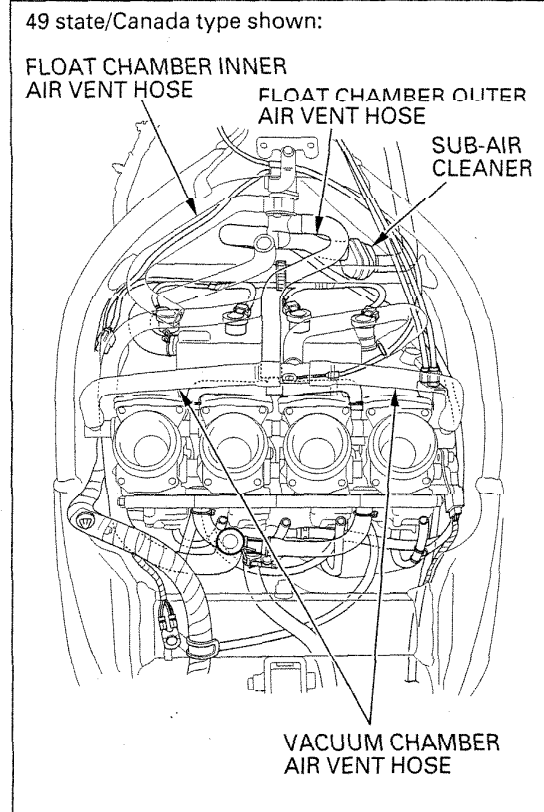

Disconnect the air vent hose (California: No. 6) from the 3-way joint that goes to the carburetor.
Disconnect the No. 4 hose (California type).

Blow air into the inner air vent hose (California: No. 7) with the ignition switch OFF.
Blow air into the outer air vent hose (California: No. 4) with the ignition switch ON.

Air should flow through the solenoid valve and out the air vent hose (California: No. 6) that goes to the carburetor.

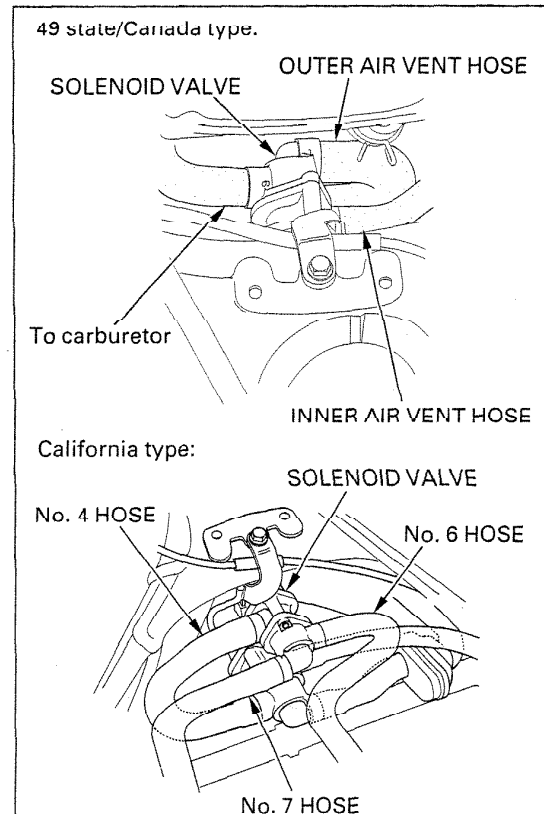

FUEL PUMP

DISCHARGE VOLUME INSPECTION

▲WARNING

Gasoline is extremely flammable and is explosive under certain conditions. Work in a well ventilated area. Smoking or allowing flames or sparks in the work area or where the gasoline is stored can cause a fire or explosion.

Raise the fuel tank and support it (page 2-3).
Remove the seat cowl (page 2-2).

Short the Black/white and Black/blue terminals at the fuel pump transfer relay with the jumper wire.

Disconnect the fuel tube from the 3-way tube joint that goes to the carburetor.
Hold the a graduated beaker under the fuel tube.

Turn the ignition switch ON (engine stopped) with the engine stop switch to RUN and let the fuel flow into the beaker for 5 seconds, then turn the ignition switch OFF.

Multiply the amount in the beaker by 12 to determine the fuel pump flow capacity per minute.

FUEL PUMP FLOW CAPACITY (minimum):
700 cm³ (23.7 US oz , 24.6 Imp oz)/minute

49 state/Canada type shown:

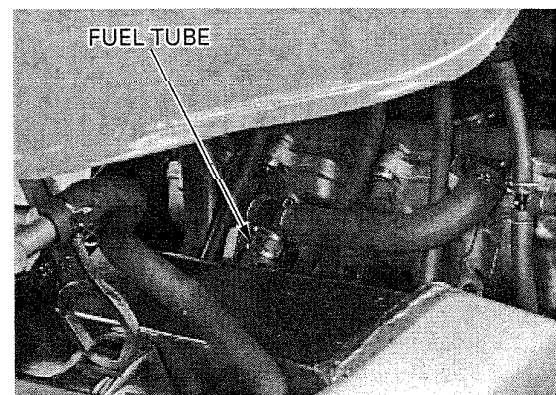
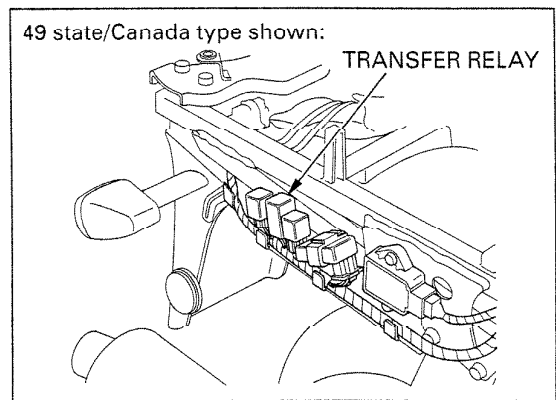

SECONDARY AIR SUPPLY SYSTEM

SYSTEM INSPECTION

Start the engine and warm it up to normal operating temperature.

Remove the air cleaner housing cover (page 3-5).
Check that the secondary air intake port is clean and free of carbon deposits.

Check the pulse secondary air injection (PAIR) check valves if the port is carbon fouled.

Disconnect the air supply (air cleaner housing-to-PAIR control valve) hose (California: No. 15) from the air cleaner housing.

Disconnect the PAIR control valve vacuum tube (California: No. 10) from the 3-way joint and plug the 3-way joint.

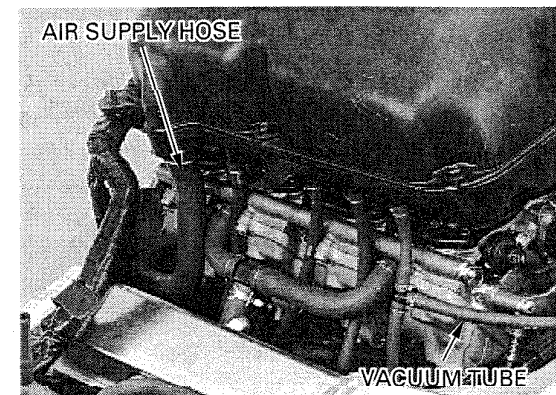
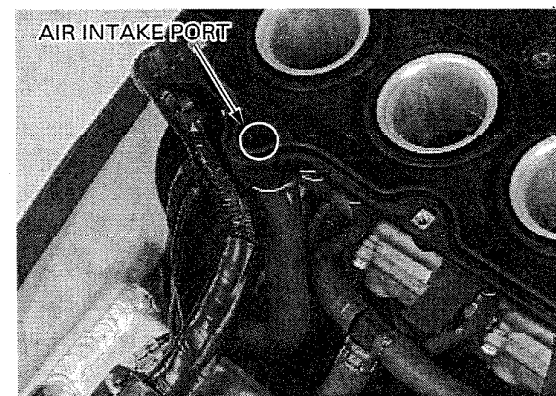

FUEL SYSTEM

Connect a vacuum pump to the PAIR control valve vacuum tube (California: No. 10).

Start the engine and open the throttle slightly to be certain that air is sucked in through the air supply hose (California: No. 15).

If the air is not drawn in, check the air supply hoses for clogging.

With the engine running, gradually apply vacuum to the PAIR control valve vacuum tube. Check that the air supply hose stops drawing air, and that the vacuum does not bleed.

SPECIFIED VACUUM: 400 mm Hg (15.7 in Hg)

If the air is drawn in, or if the specified vacuum is not maintained, install a new PAIR control valve. If afterburn occurs on deceleration, even when the secondary air supply system is normal, check the air cut-off valve.

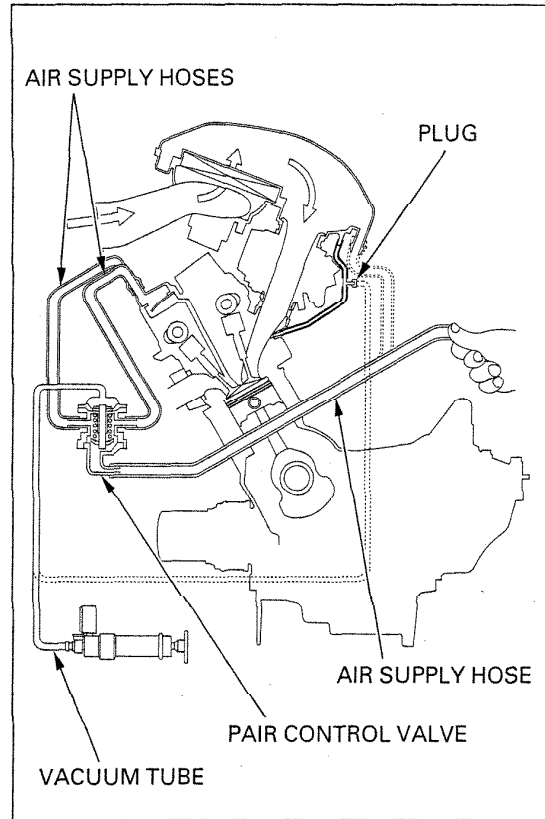

PAIR CHECK VALVE INSPECTION

Remove the radiator without disconnecting the water hoses (page 3-6).

Remove the bolts and PAIR check valve cover from the cylinder head cover.

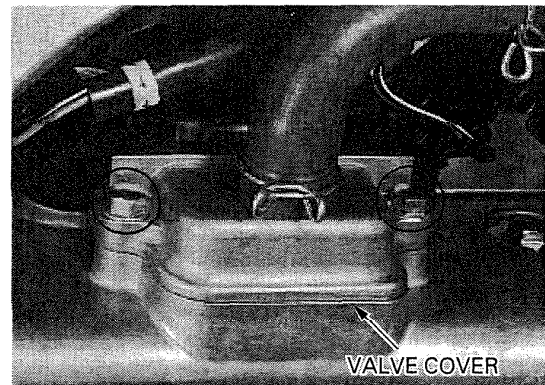

Remove the PAIR check valves.

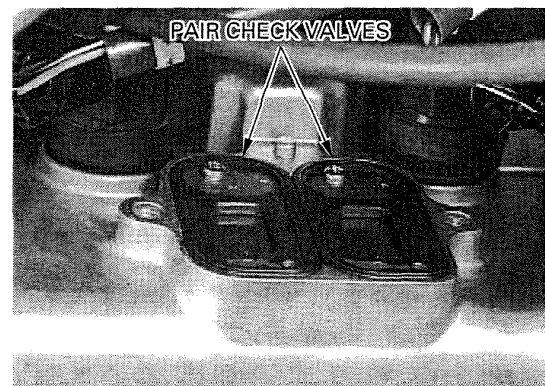

Check the reed for damage or fatigue. Replace if necessary.

Replace the PAIR check valve if the seat rubber is cracked, deteriorated or damaged, or if there is clearance between the reed and seat.

Install the PAIR check valves and cover onto the cylinder head cover.
Install the cover bolts and tighten them.

TORQUE : 13 N·m (1.3 kgf·m , 9 lbf·ft)

Install the radiator (page 3-7).

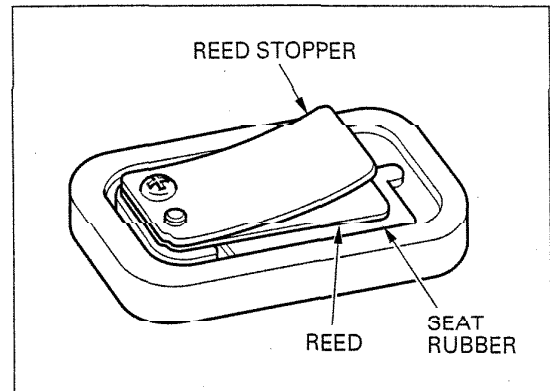

PAIR CONTROL VALVE REMOVAL/INSTALLATION

Remove the radiator without disconnecting the water hoses (page 3-6).

Disconnect the air supply hoses and vacuum tube to remove the PAIR control valve.

Installation is in the reverse order of removal.

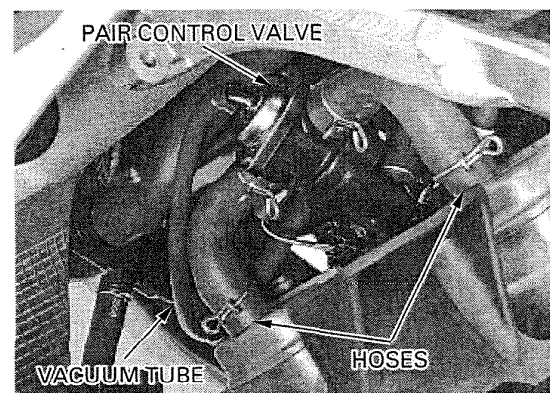

EVAPORATIVE EMISSION CONTROL SYSTEM (California type only)

NOTE:

Refer to the Vacuum Hose Routing Diagram Label and Cable & Harness Routing (page 1-18) for the tube connections and routing.

EVAPORATIVE EMISSION (EVAP) CANISTER REMOVAL/INSTALLATION

Disconnect the No. 1, No. 4 and No. 2 tubes from the EVAP canister.

Remove the 6 mm mounting bolt.
Remove the side fairing socket bolt and fairing stay, and the EVAP canister with the bracket.

Remove the two bolts, collars and bracket.

Install the EVAP canister in the reverse order of removal.

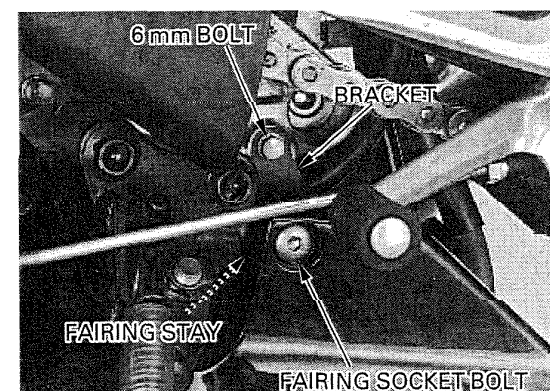
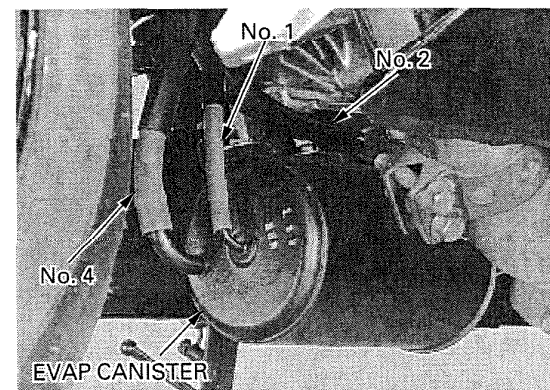

FUEL SYSTEM

EVAPORATIVE EMISSION (EVAP) PURGE CONTROL VALVE INSPECTION

NOTE:

The EVAP purge control valve should be inspected if hot restart is difficult.

Raise the fuel tank and support it (page 2-3).
Remove the EVAP purge control valve.

Connect a vacuum pump to the No. 5 tube fitting (output port) that goes to the carburetors. Apply the specified vacuum to the EVAP purge control valve.

SPECIFIED VACUUM: 250 mm Hg (9.8 in Hg)

The specified vacuum should be maintained.
Replace the EVAP purge control valve if vacuum is not maintained.

Remove the vacuum pump and connect it to the No. 11 tube fitting (vacuum port) that goes to the # 4 carburetor.
Apply the specified vacuum to the EVAP purge control valve.

SPECIFIED VACUUM: 250 mm Hg (9.8 in Hg)

The specified vacuum should be maintained.
Replace the EVAP purge control valve if vacuum is not maintained.

Connect a pressure pump to the No. 4 tube fitting (input port) that goes to EVAP canister.

CAUTION:

Damage to the EVAP purge control valve may result from use of a high pressure air source. Use a hand-operated air pump only.

While applying the specified vacuum to the EVAP purge control valve vacuum port, pump air through the input port.

SPECIFIED VACUUM: 250 mm Hg (9.8 in Hg)

Air should flow through the EVAP purge control valve and out the output port that goes to the carburetors.
Replace the EVAP purge control valve if air does not flow out.

Remove the pumps and install the EVAP purge control valve.

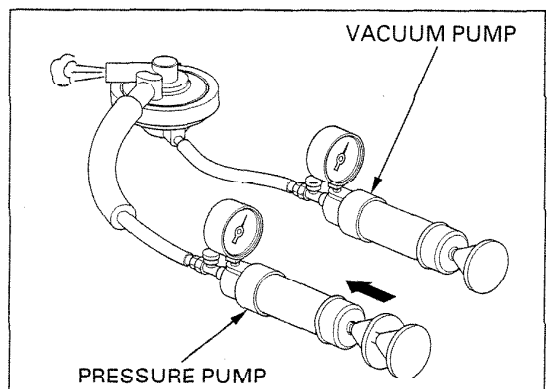
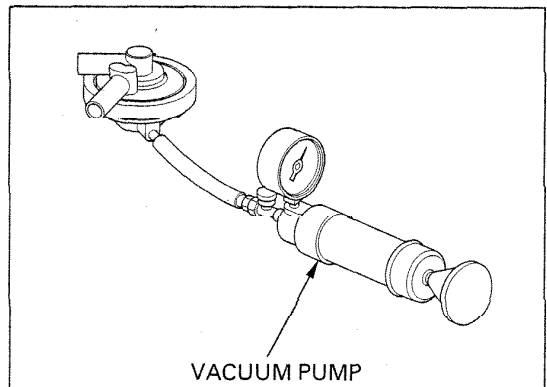
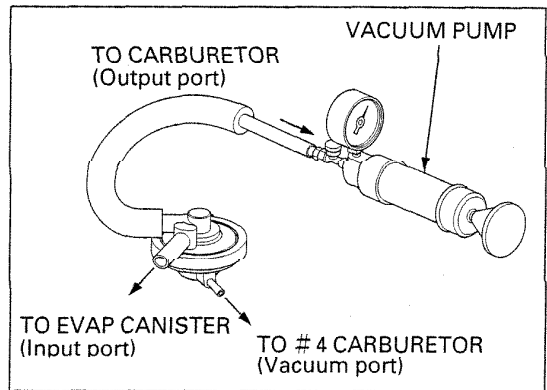
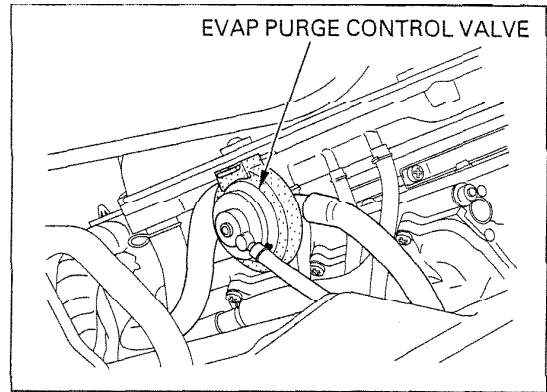

**EVAPORATIVE EMISSION
CARBURETOR AIR VENT (EVAP CAV)
SOLENOID VALVE INSPECTION**

NOTE:

The EVAP CAV solenoid valve should be inspected if hot restart is difficult.

Remove the air cleaner housing (page 5-14).
Remove the bolt and solenoid valve stay from the frame.
Disconnect the No. 8 and No. 4 hoses.

Blow air into the No. 4 hose fitting that goes to the EVAP canister with the ignition switch OFF.
Blow air into the No. 8 hose fitting with the ignition switch ON.

Air should flow through the EVAP CAV solenoid valve and out the air vent port (No. 4 hose fitting) that goes to the air vent control solenoid valve.

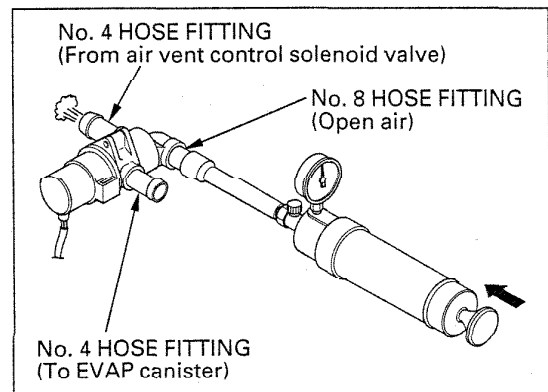
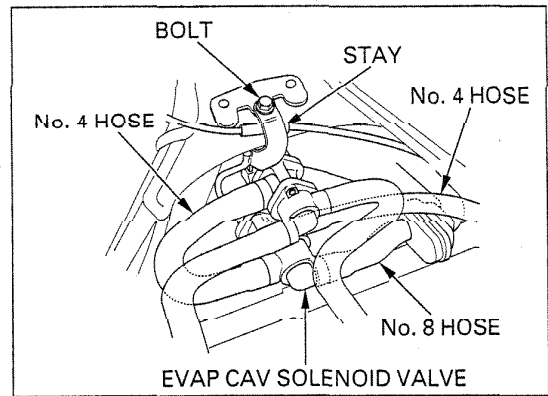

COOLING SYSTEM

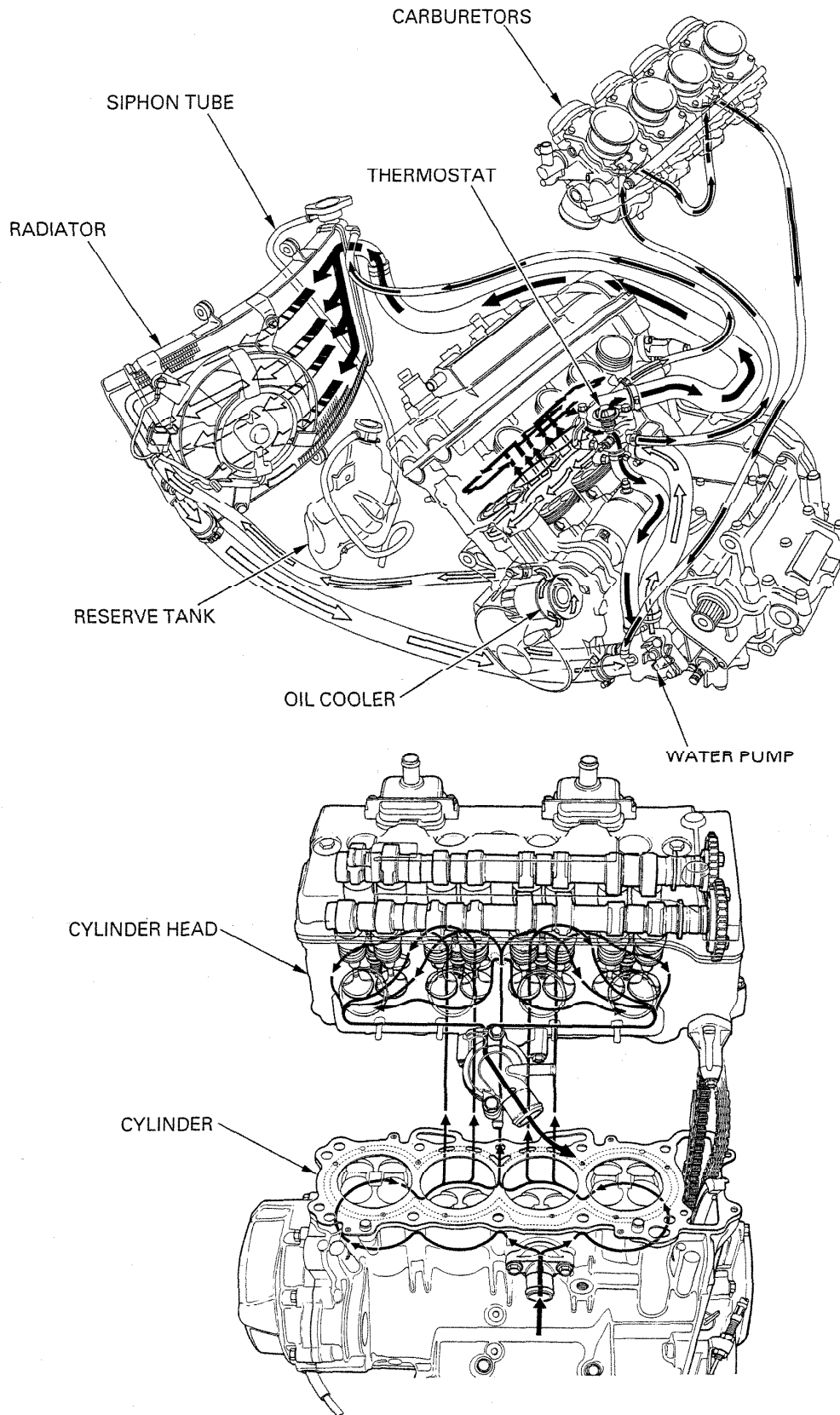

6. COOLING SYSTEM

SERVICE INFORMATION	6-1	THERMOSTAT	6-6
TROUBLESHOOTING	6-2	RADIATOR/COOLING FAN	6-8
SYSTEM TESTING	6-3	RADIATOR RESERVE TANK	6-11
COOLANT REPLACEMENT	6-4	WATER PUMP	6-12

SERVICE INFORMATION

GENERAL

▲WARNING

- Wait until the engine is cool before slowly removing the radiator cap. Removing the cap while the engine is hot and the coolant is under pressure may cause serious scalding.
- Radiator coolant is toxic. Keep it away from eyes, mouth, skin and clothes.
 - If any coolant gets in your eyes, rinse them with water and consult a doctor immediately.
 - If any coolant is swallowed, induce vomiting, gargle and consult a physician immediately.
 - If any coolant gets on your skin or clothes, rinse thoroughly with plenty of water.
- KEEP OUT OF REACH OF CHILDREN.

CAUTION:

Using coolant with silicate corrosion inhibitors may cause premature wear of water pump seals or blockage of radiator passage.
Using tap water may cause engine damage.

- Add coolant at the reserve tank. Do not remove the radiator cap except to refill or drain the system.
- All cooling system service can be done with the engine in the frame.
- Avoid spilling coolant on painted surfaces.
- After servicing the system, check for leaks with a cooling system tester.
- Refer to section 19 for fan motor switch and thermosensor inspection.

SPECIFICATIONS

ITEM		SPECIFICATIONS
Coolant capacity	Radiator and engine	2.7 l (2.9 US qt, 2.4 Imp qt)
	Reserve tank	0.31 l (0.33 US qt, 0.27 Imp qt)
Radiator cap relief pressure		108–137 kPa (1.1–1.4 kgf/cm ² , 16–20 psi)
Thermostat	Begin to open	73–77 °C (163–171 °F)
	Fully open	90 °C (194 °F)
	Valve lift	8 mm (0.3 in) minimum
Recommended antifreeze		Pro Honda HP Coolant or an equivalent high quality ethylene glycol antifreeze containing silicate-free corrosion inhibitors.

TORQUE VALUES

Water pump assembly bolt	12 N·m (1.2 kgf·m, 9 lbf·ft)
Thermostat cover bolt	12 N·m (1.2 kgf·m, 9 lbf·ft)

COOLING SYSTEM

TROUBLESHOOTING

Engine temperature too high

- Faulty temperature gauge or thermosensor
- Thermostat stuck closed
- Faulty radiator cap
- Insufficient coolant
- Passenges blocked in radiator, hoses or water jacket
- Air in system
- Faulty cooling fan motor
- Faulty fan motor switch
- Faulty water pump

Engine temperature too low

- Faulty temperature gauge or thermosensor
- Thermostat stuck open
- Faulty fan motor switch

Coolant leaks

- Faulty water pump mechanical seal
- Deteriorated O-rings
- Faulty radiator cap
- Damaged or deteriorated cylinder head gasket
- Loose hose connection or clamp
- Damaged or deteriorated hoses

SYSTEM TESTING

▲WARNING

The engine must be cool before removing the radiator cap; or severe scalding may result.

Remove the right air intake duct (page 2-6).

Remove the radiator cap.

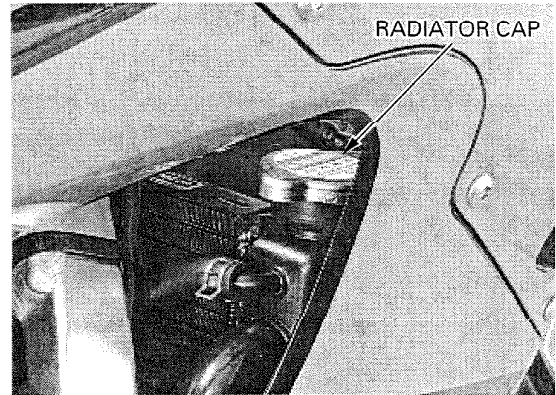

COOLANT (HYDROMETER TEST)

Test the coolant gravity using a hydrometer.

STANDARD COOLANT CONCENTRATION: 50%

Look for contamination and replace the coolant if necessary.

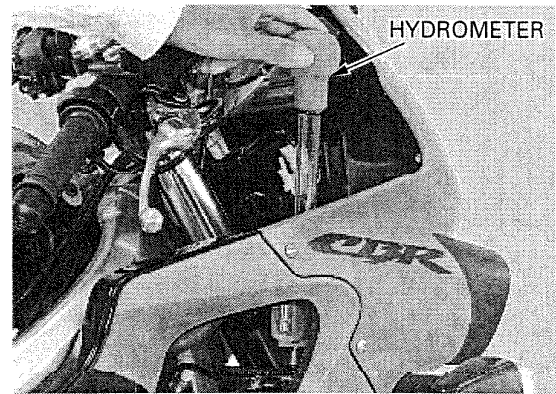

Coolant temperature °(°F)	0	5	10	15	20	25	30	35	40	45	50
	(32)	(41)	(50)	(59)	(68)	(77)	(86)	(95)	(104)	(113)	(122)
Coolant ratio %											
5	1.009	1.009	1.008	1.008	1.007	1.006	1.005	1.003	1.001	0.999	0.997
10	1.018	1.017	1.017	1.016	1.015	1.014	1.013	1.011	1.009	1.007	1.005
15	1.028	1.027	1.026	1.025	1.024	1.022	1.020	1.018	1.016	1.014	1.012
20	1.036	1.035	1.034	1.033	1.031	1.029	1.027	1.025	1.023	1.021	1.019
25	1.045	1.044	1.043	1.042	1.040	1.038	1.036	1.034	1.031	1.028	1.025
30	1.053	1.052	1.051	1.049	1.047	1.045	1.043	1.041	1.038	1.035	1.032
35	1.063	1.062	1.060	1.058	1.056	1.054	1.052	1.049	1.046	1.043	1.040
40	1.072	1.070	1.068	1.066	1.064	1.062	1.059	1.056	1.053	1.050	1.047
45	1.080	1.078	1.076	1.074	1.072	1.069	1.066	1.063	1.060	1.057	1.054
50	1.086	1.084	1.082	1.080	1.077	1.074	1.071	1.068	1.065	1.062	1.059
55	1.095	1.093	1.091	1.088	1.085	1.082	1.079	1.076	1.073	1.070	1.067
60	1.100	1.098	1.095	1.092	1.089	1.086	1.083	1.080	1.077	1.074	1.071

COOLING SYSTEM

RADIATOR CAP/SYSTEM PRESSURE INSPECTION

Before installing the cap in the tester, wet the sealing surfaces.

Pressure test the radiator cap using the tester. Replace the radiator cap if it does not hold pressure, or if relief pressure is too high or too low, it must hold specified pressure for at least 6 seconds.

RADIATOR CAP RELIEF PRESSURE:

108 – 137 kPa (1.1 – 1.4 kgf/cm², 16 – 20 psi)

Pressure the radiator, engine and hoses using the tester, and check for leaks.

CAUTION:

Excessive pressure can damage the cooling system components. Do not exceed 137 kPa (1.4 kgf/cm², 20 psi).

Repair or replace components if the system will not hold specified pressure for at least 6 seconds.

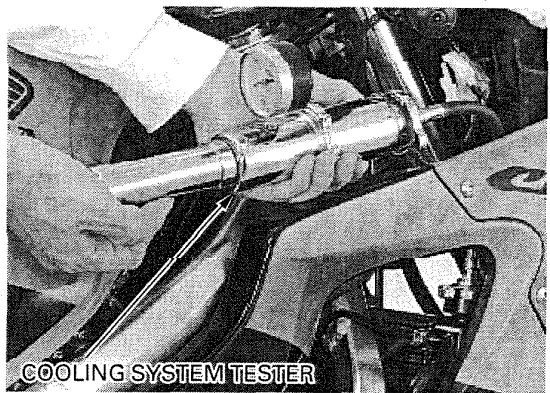
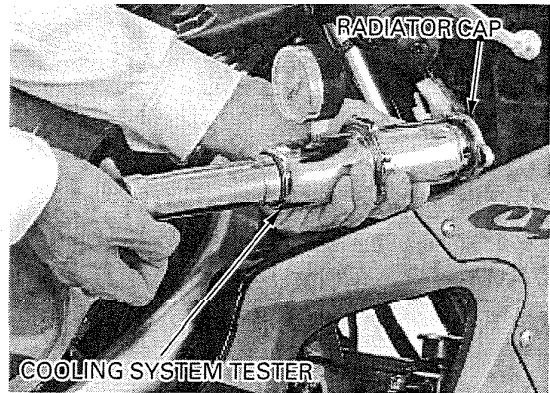

COOLANT REPLACEMENT

PREPARATION

▲WARNING

- **Radiator coolant is toxic. Keep it away from eyes, mouth, skin and clothes.**
 - If any coolant gets in your eyes, rinse them with water and consult a doctor immediately.
 - If any coolant is swallowed, induce vomiting, gargle and consult a physician immediately.
 - If any coolant gets on your skin or clothes, rinse thoroughly with plenty of water.
- **KEEP OUT OF REACH OF CHILDREN.**

CAUTION:

Using coolant with silicate corrosion inhibitors may cause premature wear of water pump seals or blockage of radiator passage. Using tap water may cause engine damage.

NOTE:

- The effectiveness of coolant decreases with the accumulation of rust or if there is a change in the mixing proportion during usage. Therefore, for best performance change the coolant regularly as specified in the maintenance schedule.
- Mix only distilled, low mineral water with the antifreeze.

RECOMMENDED MIXTURE:

50 – 50 (Distilled water and antifreeze)

RECOMMENDED ANTIFREEZE:

Pro Honda HP Coolant or an equivalent high quality ethylene glycol antifreeze containing silicate-free corrosion inhibitors

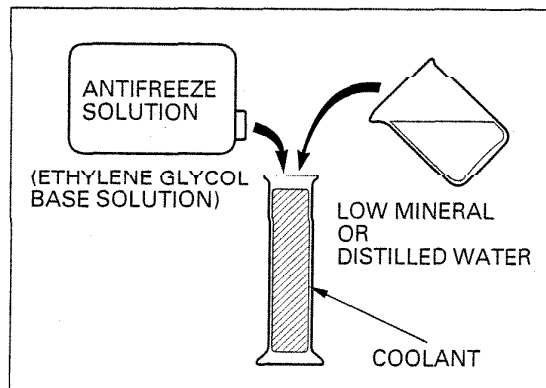

REPLACEMENT/AIR BLEEDING

▲WARNING

The engine must be cool before servicing the cooling system, or severe scalding may result.

NOTE

When filling the system or reserve tank with a coolant (checking the coolant level), place the motorcycle upright on a flat, level surface.

Remove the right air intake duct (page 2-6).
Remove the left side fairing (page 2-4).

Remove the radiator cap.

Remove the drain bolt on the water pump and drain the coolant from the system.

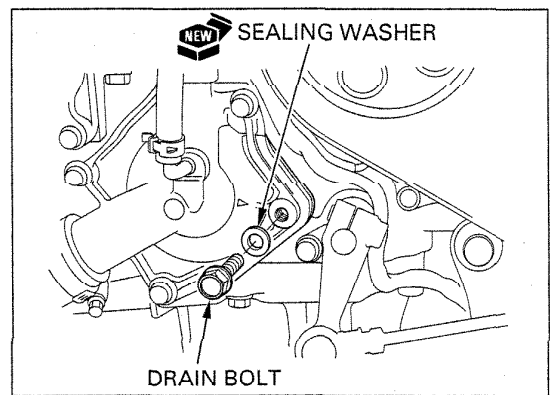

Remove the radiator without disconnecting the water hoses (page 3-6).
Remove the drain bolt on the cylinder and drain the coolant from the cylinder.

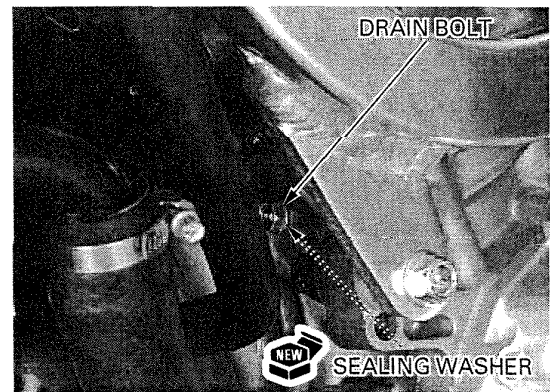

Remove the reserve tank cap.
Slide the heat guard rubber out of the way, disconnect the siphon tube, and drain the coolant from the reserve tank.

Connect the siphon tube and install the drain bolts with new sealing washers.

Install the radiator onto the frame (page 3-7).

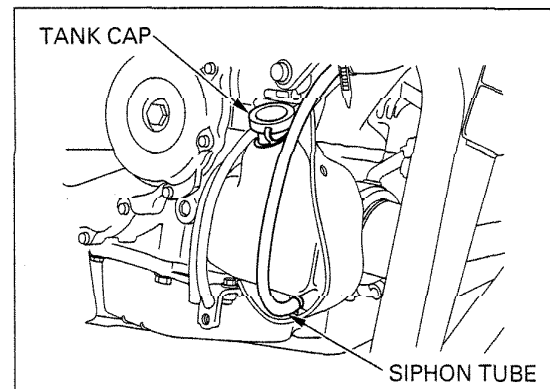

COOLING SYSTEM

Fill the system with the recommended coolant up to the filler neck.

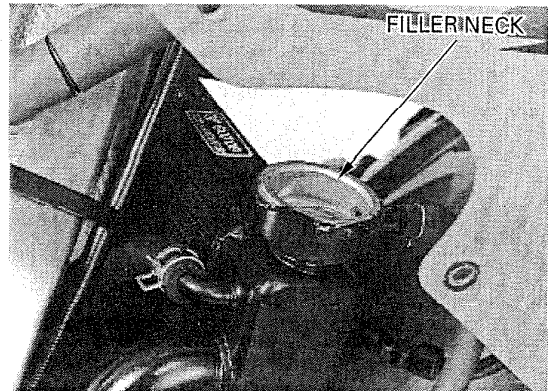

Fill the reserve tank to the upper level line.

Bleed air from the system as follows:

1. Shift the transmission into neutral.
Start the engine and let it idle for 2–3 minutes.
2. Snap the throttle 3–4 times to bleed air from the system.
3. Stop the engine and add coolant up to the filler neck.
4. Install the radiator cap.

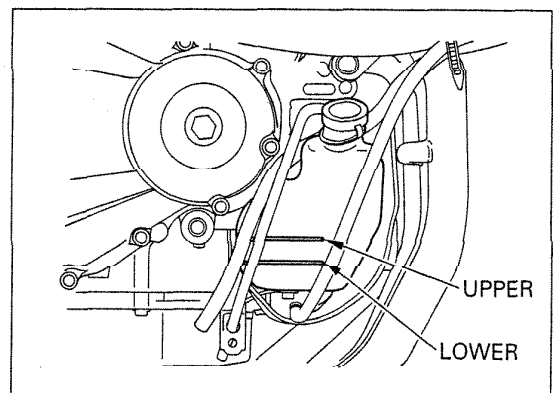

Fill the reserve tank to the upper level line and install the reserve tank cap.

Install the right air intake duct (page 2-6).
Install the side fairings (page 2-4).

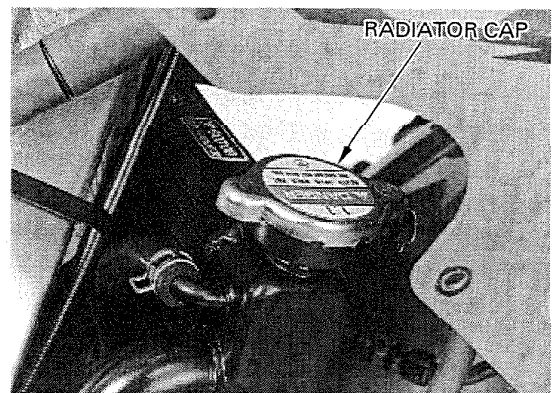

THERMOSTAT

REMOVAL

▲WARNING

The engine must be cool before servicing the cooling system, or severe scalding may result.

Drain the coolant from the system (page 6-5).
Remove the carburetor (page 5-15).

Remove the bolts and thermostat housing cover.



Remove the thermostat.

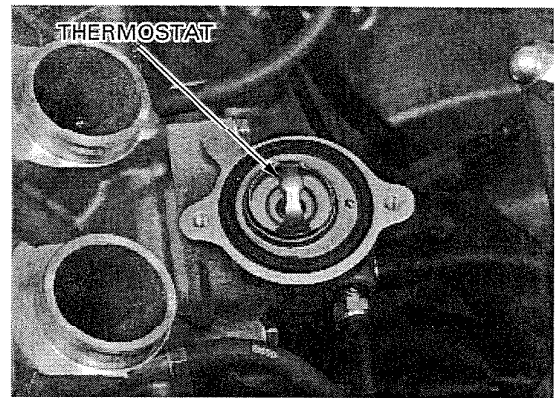

INSPECTION

▲WARNING

- *Wear insulated gloves and adequate eye protection.*
- *Keep flammable materials away from the electric heating element.*

Visually inspect the thermostat for damage. Replace the thermostat if the valve stays open at room temperature.

Heat the water with an electric heating element to operating temperature for 5 minutes. Suspend the thermostat in heated water to check its operation.

NOTE:

Do not let the thermometer or thermostat touch the pan, or you will get false readings.

THERMOSTAT BEGINS TO OPEN:

73–77 °C (163–171 °F)

VALVE LIFT:

8 mm (0.3 in) minimum at 90 °C (194 °F)

Replace the thermostat if the valve responds at temperature other than those specified.

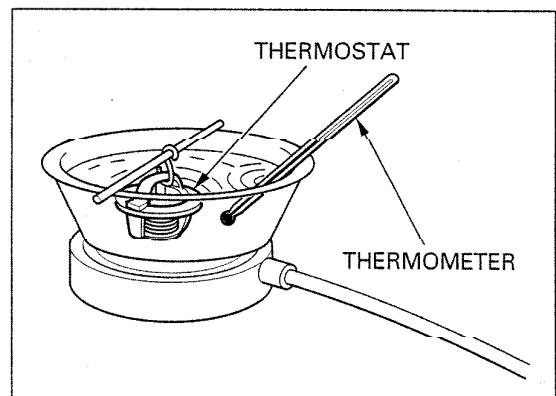

INSTALLATION

Install a new seal rubber over the thermostat flange.

Apply coolant to the seal rubber and install the thermostat into the housing with its hole facing rearward.

CAUTION:

Do not allow the seal rubber to turn inside out. It will cause the coolant to leak.

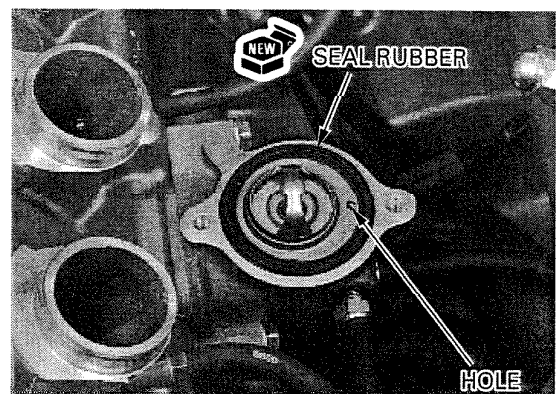

COOLING SYSTEM

Install the thermostat housing cover and tighten the cover bolts.

TORQUE : 12 N·m (1.2 kgf·m , 9 lbf·ft)

Install the carburetor (page 5-30).
Fill and bleed the cooling system (page 6-4).



RADIATOR/COOLING FAN

CAUTION:

Be careful not to damage the radiator fins while servicing the radiator.

RADIATOR REMOVAL/ INSTALLATION

Drain the coolant from the system by removing the drain bolt on the water pump (page 6-5).

Disconnect the fan motor 2P (Black) connector.

Disconnect the horn connectors. Remove the horn bolt and horn.

Disconnect the water hoses and tubes from the radiator.

Remove the radiator mounting bolts, washers and nut.
Remove the radiator from the mounting boss of the frame.

Remove the air guide rubber from the engine.

Installation is in the reverse order of removal.

NOTE:

Set the air guide rubber properly, being careful not to pinch it between the frame and radiator.

Fill and bleed the cooling system (page 6-4).

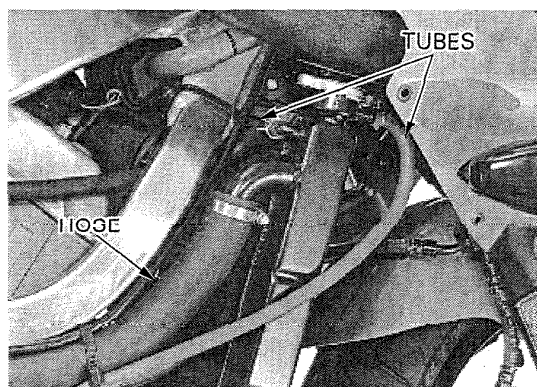
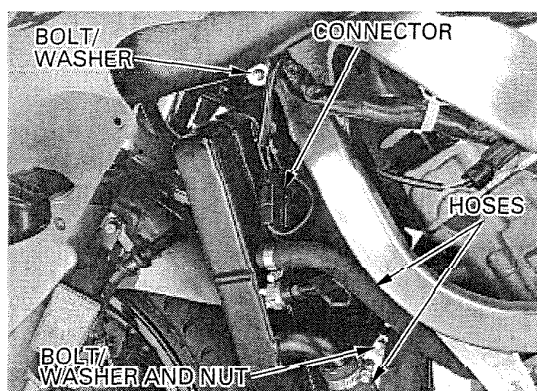

COOLING FAN DISASSEMBLY

Remove the radiator (page 6-8).

Remove the mounting collar.
Remove the air guide rubber from the radiator.

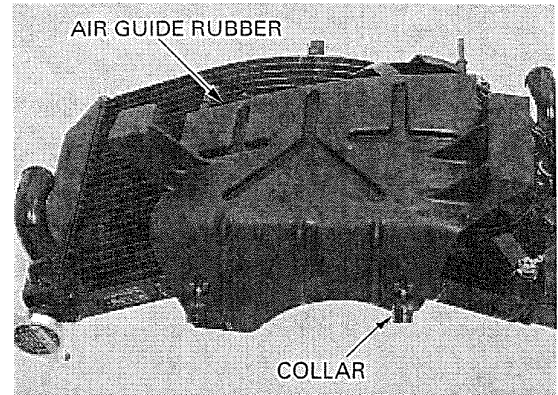

Disconnect the fan motor switch connector.
Remove the fan motor assembly by removing the three bolts and ground terminal.

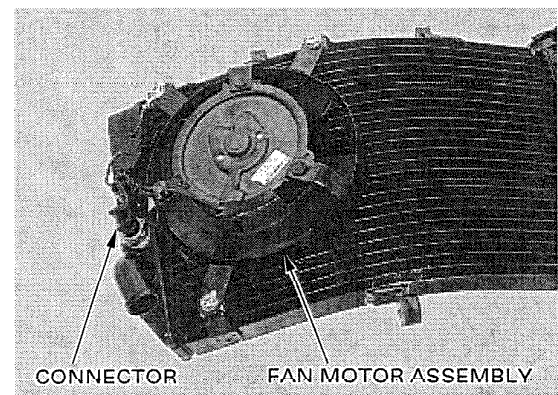

Remove the nuts and the cooling fan from the fan motor.

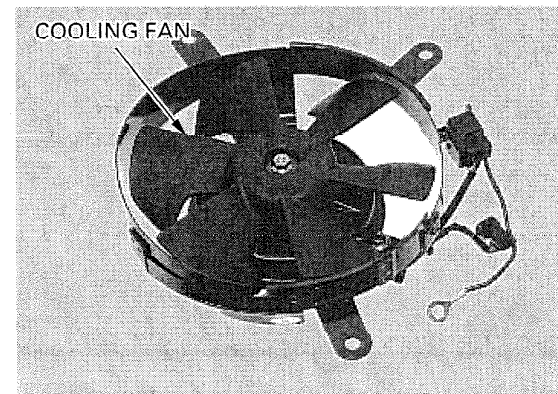

Remove the fan motor connector from the shroud and the motor wire from the clamp.
Remove the nuts and the fan motor.

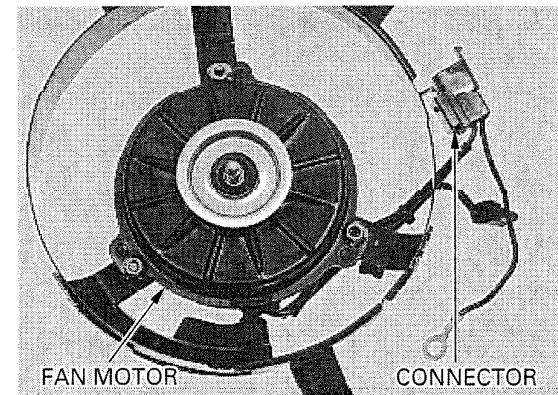

COOLING SYSTEM

COOLING FAN ASSEMBLY

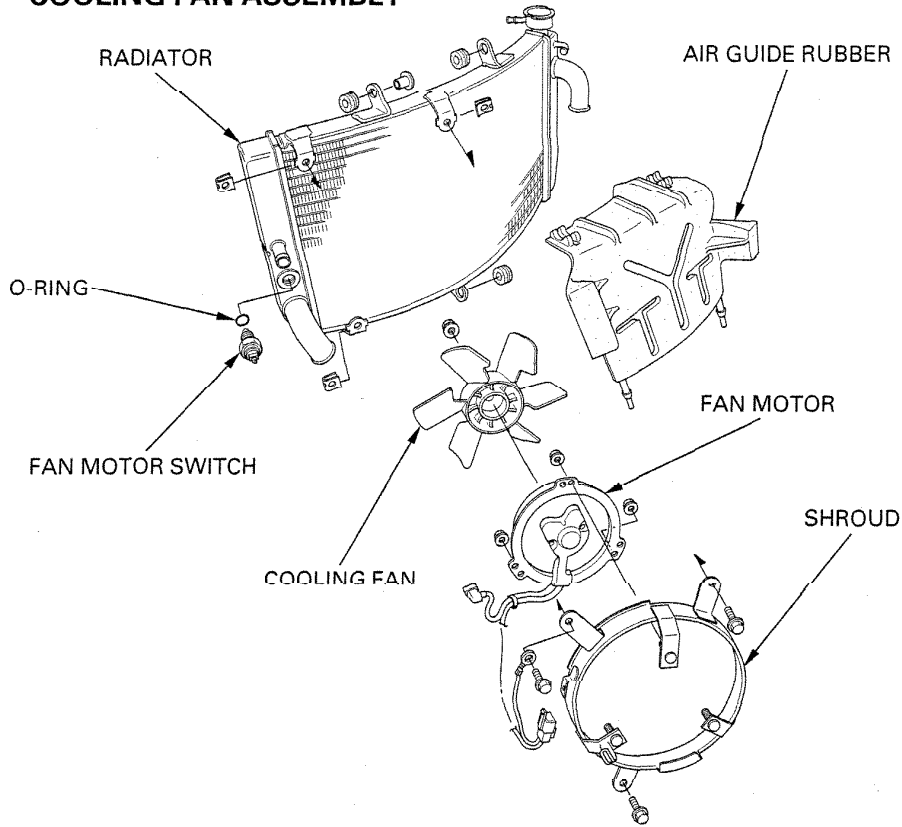

Install the fan motor onto the shroud as shown.
Install and tighten the nuts.
Install the fan motor connector onto the shroud and
secure the wire with the clamp.

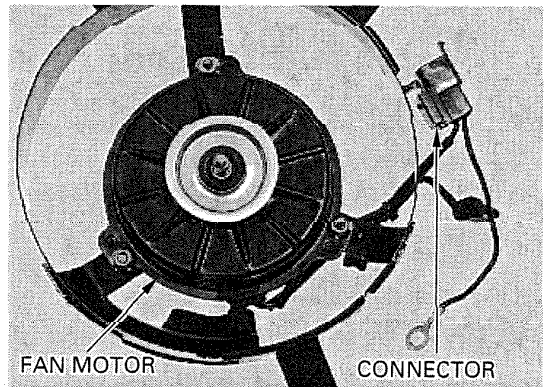

Install the cooling fan onto the motor shaft by aligning the flat surfaces.
Install and tighten the nut.

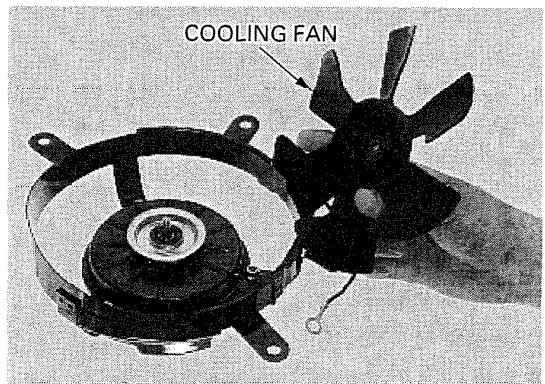

Install the fan motor assembly onto the radiator and tighten the mounting bolts with the ground terminal.

Connect the fan motor switch connector.

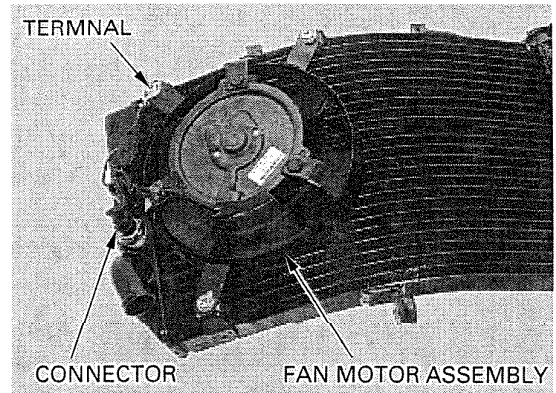

Install the air guide rubber over the radiator stays properly.
Install the mounting collar into the right side of the left grommet.

Install the radiator (page 6-8).

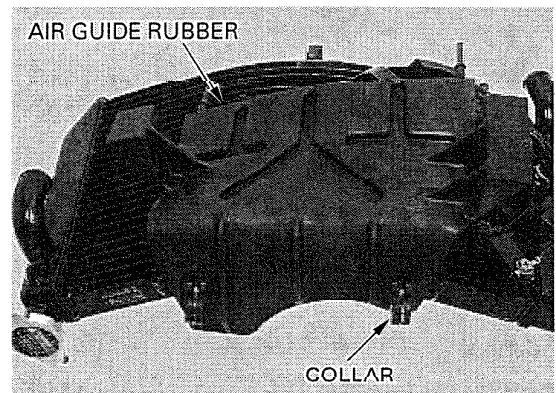

RADIATOR RESERVE TANK

REMOVAL/INSTALLATION

Drain the coolant from the reserve tank (page 6-5).

Remove the breather tube from the reserve tank stay.

Remove the mounting bolt, and the reserve tank and heat guard rubber from the stay.

Align the locating pin with the hole in the stay.

Installation is in the reverse order of removal.

NOTE:

Route the tubes properly (page 1-10).

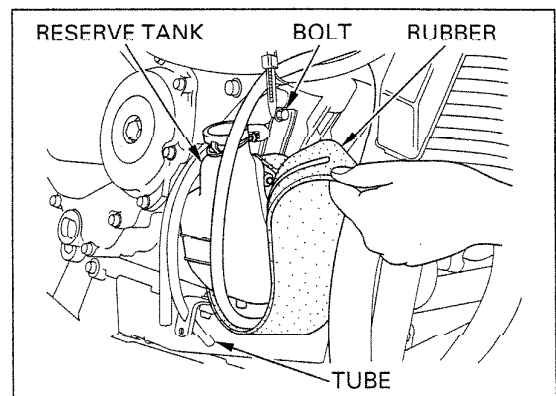

Fill the reserve tank with recommended coolant to the upper level line (page 3-14).

COOLING SYSTEM

WATER PUMP

MECHANICAL SEAL INSPECTION

Inspect the telltale hole for signs of coolant leakage. If there is leakage, the mechanical seal is defective and replace the water pump as an assembly.

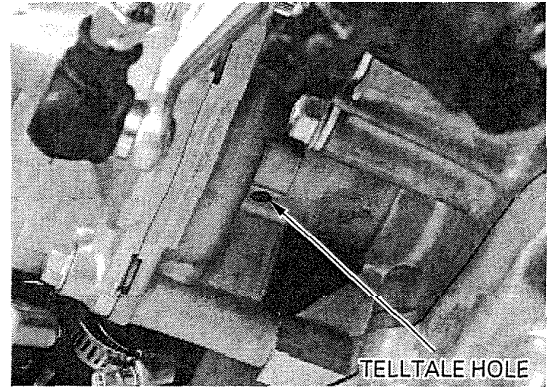

REMOVAL

Drain the coolant from the system by removing the drain bolt on the water pump (page 6-5).

Disconnect the water tube and hoses from the water pump cover.

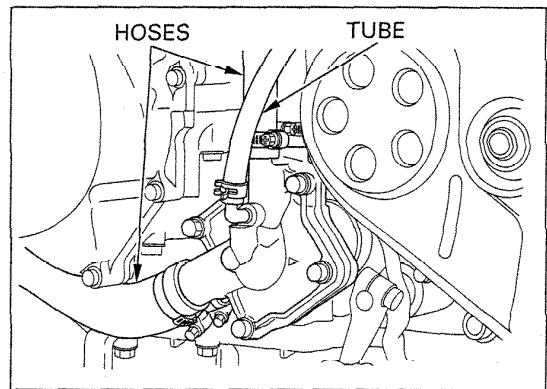

Remove the four bolts and water pump cover.

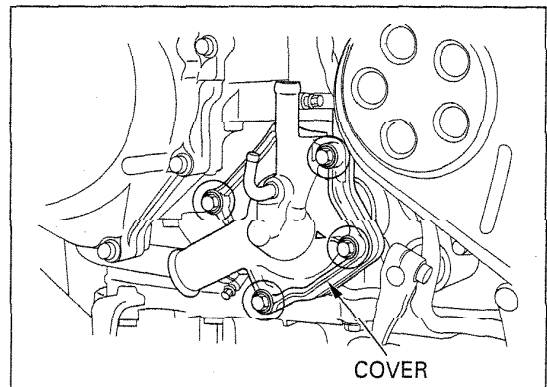

Remove the O-ring.
Disconnect the water hoses.
Remove the pump body from the crankcase.

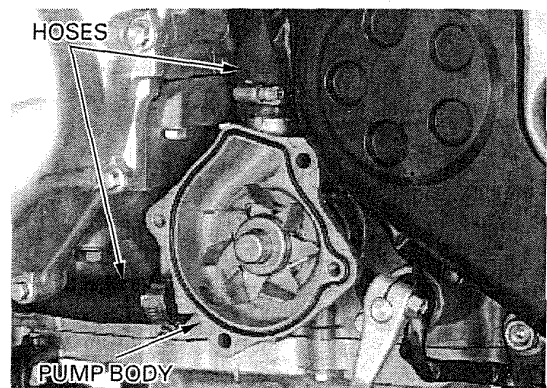

INSTALLATION

Pour the molybdenum oil solution into the hole in the water pump as shown.
 Apply molybdenum oil solution to the thrust washer.
 Apply engine oil to a new O-ring and install it onto the stepped portion of the water pump.

Install the water pump into the crankcase while aligning the water pump shaft groove with the oil pump shaft end by turning the pump shaft.

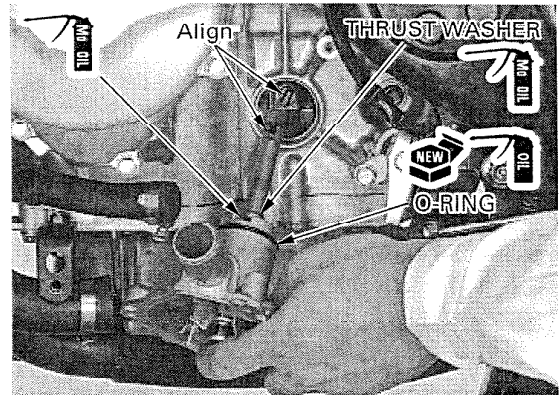

Align the bolt holes in the water pump and crankcase and make sure the water pump is securely installed.

Connect the water hoses to the pump body.

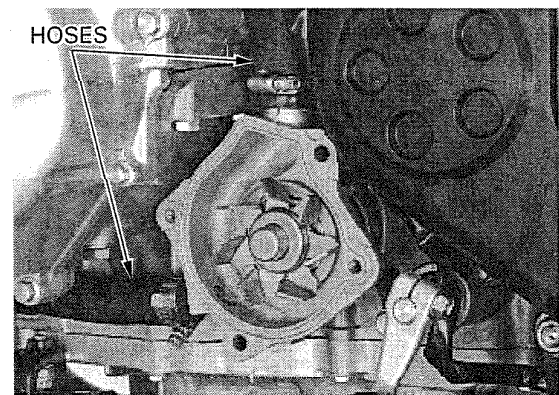

Install a new O-ring into the groove in the water pump body.

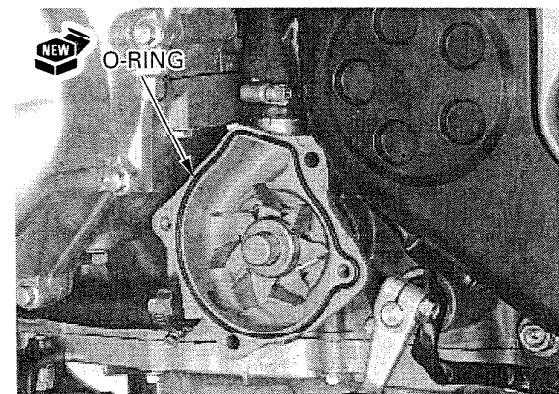

Install the water pump cover and tighten the bolts with a new sealing washer.

TORQUE : 12 N·m (1.2 kgf·m , 9 lbf·ft)

Connect the water hoses and tube.

Fill and bleed the cooling system (page 6-4).

