

CRANKCASE/TRANSMISSION

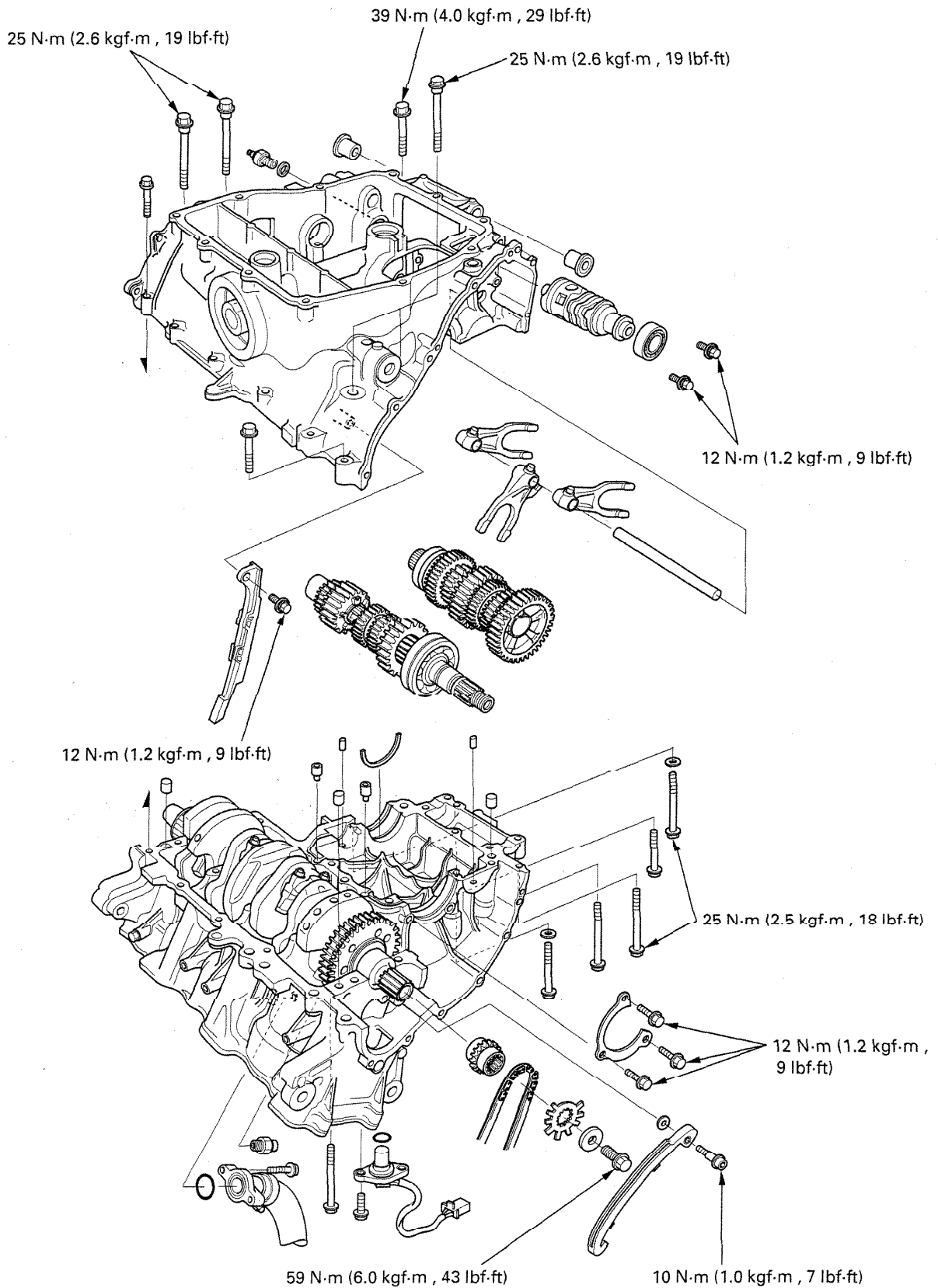

11. CRANKCASE/TRANSMISSION

SERVICE INFORMATION	11-1	SHIFT FORK/SHIFT DRUM	11-4
TROUBLESHOOTING	11-2	TRANSMISSION	11-6
CRANKCASE SEPARATION	11-3	CRANKCASE ASSEMBLY	11-11

SERVICE INFORMATION

GENERAL

- The crankcase must be separated to service the following:
 - transmission
 - crankshaft (section 12)
 - piston/connecting rod (section 12)
- The following components must be removed before separating the crankcase:
 - engine (section 7)
 - oil pan, oil pump and oil cooler (section 4)
 - water pump (section 6)
 - cylinder head (section 8)
 - clutch/gearshift linkage (section 9)
 - flywheel (section 10)
 - starter motor (section 18)
- Be careful not to damage the crankcase mating surfaces when servicing.
- Prior to assembling the crankcase halves, apply sealant to their mating surfaces. Wipe off excess sealant thoroughly.

11

SPECIFICATIONS

Unit: mm (in)

ITEM		STANDARD	SERVICE LIMIT
Shift fork	I.D.	12.000 – 12.021 (0.4724 – 0.4733)	12.03 (0.474)
	Claw thickness	5.93 – 6.00 (0.233 – 0.236)	5.9 (0.23)
Shift fork shaft	O.D.	11.957 – 11.968 (0.4707 – 0.4712)	11.95 (0.470)
Transmission	Gear I.D.	M5, M6	28.000 – 28.021 (1.1024 – 1.1032)
		C2, C3, C4	31.000 – 31.025 (1.2205 – 1.2215)
	Gear bushing O.D.	M5, M6	27.959 – 27.980 (1.1007 – 1.1016)
		C2	30.955 – 30.980 (1.2187 – 1.2197)
		C3, C4	30.950 – 30.975 (1.2185 – 1.2195)
	Gear-to-bushing clearance	M5, M6	0.020 – 0.062 (0.0008 – 0.0024)
		C2	0.020 – 0.070 (0.0008 – 0.0028)
		C3, C4	0.025 – 0.075 (0.0010 – 0.0030)
	Gear bushing I.D.	M5	24.985 – 25.006 (0.9837 – 0.9845)
		C2	27.985 – 28.006 (1.1018 – 1.1026)
	Mainshaft O.D.	at M5	24.967 – 24.980 (0.9830 – 0.9835)
	Countershaft O.D.	at C2	27.967 – 27.980 (1.1011 – 1.1016)
Bushing-to-shaft clearance	M5	0.005 – 0.039 (0.0002 – 0.0015)	
	C2	0.005 – 0.039 (0.0002 – 0.0015)	

CRANKCASE/TRANSMISSION

TORQUE VALUES

Mainshaft bearing set plate bolt	12 N·m (1.2 kgf·m , 9 lbf·ft)	Apply locking agent to the threads
Gearshift drum bearing and fork shaft set bolt	12 N·m (1.2 kgf·m , 9 lbf·ft)	Apply locking agent to the threads
Cam chain tensioner pivot bolt	10 N·m (1.0 kgf·m , 7 lbf·ft)	Apply locking agent to the threads
Cam chain guide washer bolt	12 N·m (1.2 kgf·m , 9 lbf·ft)	
Ignition pulse generator rotor bolt	59 N·m (6.0 kgf·m , 43 lbf·ft)	
Crankcase bolt (Main journal)	25 N·m (2.6 kgf·m , 19 lbf·ft)	Apply oil to the threads and seating surface
Crankcase bolt (10 mm)	39 N·m (4.0 kgf·m , 29 lbf·ft)	
Crankcase bolt (Upper side)	25 N·m (2.5 kgf·m , 18 lbf·ft)	

TOOLS

Inner driver C	07746-0030100
Attachment, 25 mm I.D.	07746-0030200

TROUBLESHOOTING

Hard to shift

- Improper clutch operation (section 9)
- Incorrect engine oil weight
- Bent shift forks
- Bent shift fork shaft
- Bent shift fork claw
- Damaged shift drum cam grooves
- Bent gearshift spindle

Transmission jumps out of gear

- Worn gear dogs
- Worn gear shifter groove
- Bent shift fork shaft
- Broken shift drum stopper arm
- Worn or bent shift forks
- Broken drum stopper arm spring
- Broken gearshift spindle return spring

Excessive engine noise

- Worn or damaged transmission gears
- Worn or damaged transmission bearings

CRANKCASE SEPARATION

Refer to Service Information (page 11-1) for removal of necessary parts before disassembling the crankcase.

Remove the bolts and water hose joint.
Remove the oil pressure switch.
Remove the bolts and speed sensor.

CAUTION:

Remove the speed sensor before separating the crankcase. Do not separate or assemble the crankcase with the speed sensor installed.

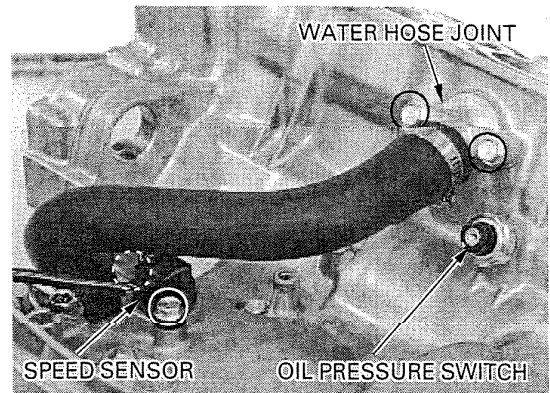

Do not use the ignition pulse generator rotor tangs to hold it in place while removing the bolt.

Remove the bolt, washer and ignition pulse generator rotor.
Remove the washer bolt and cam chain guide.
Remove the cam chain and timing sprocket.
Remove the pivot bolt, cam chain tensioner and washer.

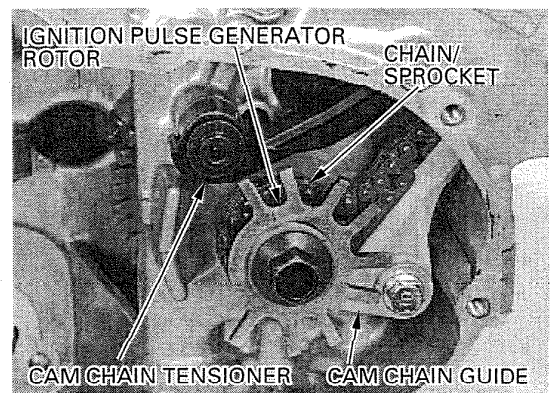

Remove the three bolts and bearing set plate.

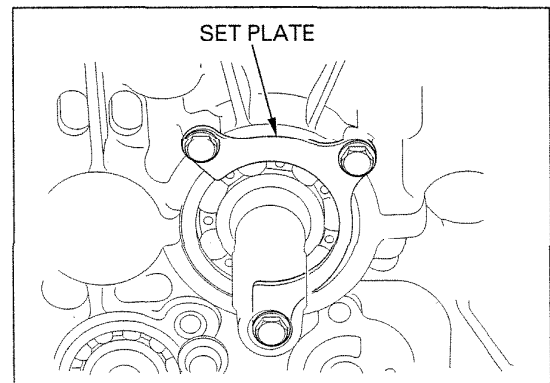

Loosen the seven 6 mm bolts and five 8 mm bolts in a crisscross pattern in 2 or 3 steps.
Remove the bolts and sealing washers.

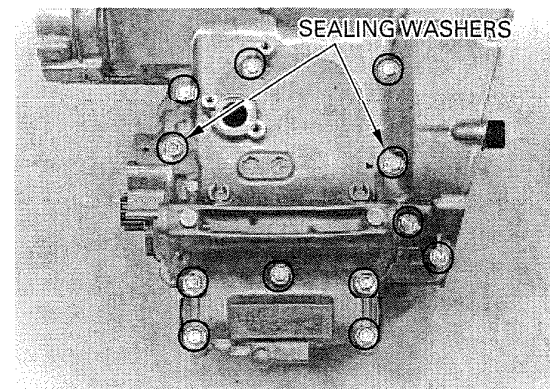

CRANKCASE/TRANSMISSION

Place the engine with the upper side down.
Loosen the eight 6 mm bolts, ten 8 mm bolts and 10 mm bolt in a crisscross pattern in 2 or 3 steps.
Remove the bolts.

Separate the lower crankcase from the upper crankcase.

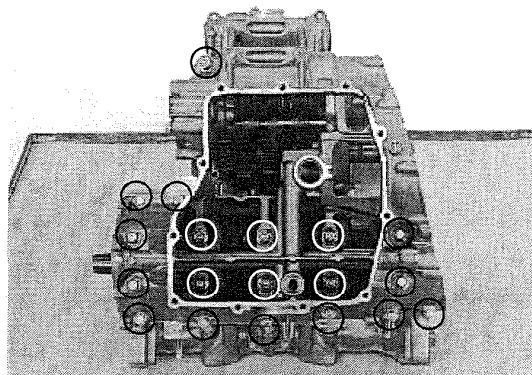

Remove the dowel pins and oil orifices.

Clean any sealant from the crankcase mating surfaces.

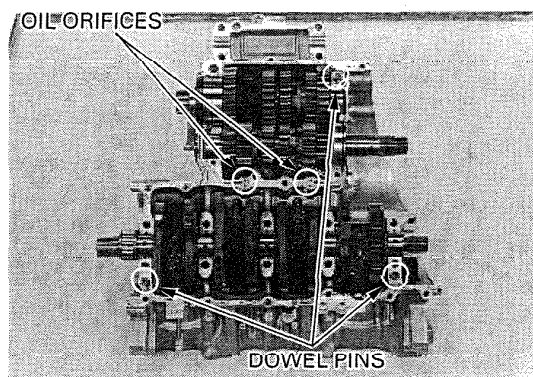

SHIFT FORK/SHIFT DRUM

REMOVAL

Separate the crankcase halves (page 11-3).

Remove the bearing set bolts.
Remove the shift fork shaft and shift forks.

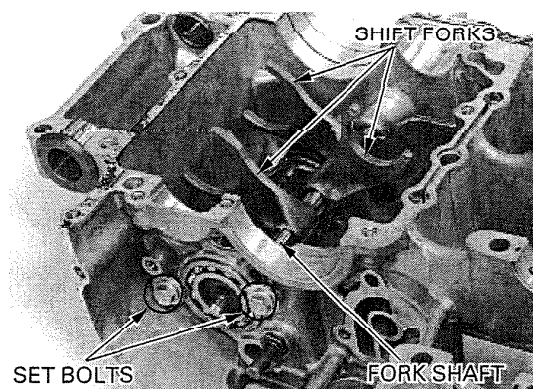

Remove the shift drum and bearing.

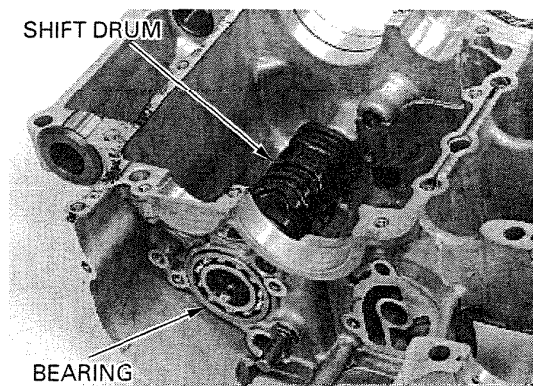

INSPECTION

Check the shift fork guide pins for abnormal wear or damage.

Measure the shift fork I.D.

SERVICE LIMIT: 12.03 mm (0.474 in)

Measure the shift fork claw thickness.

SERVICE LIMIT: 5.9 mm (0.23 in)

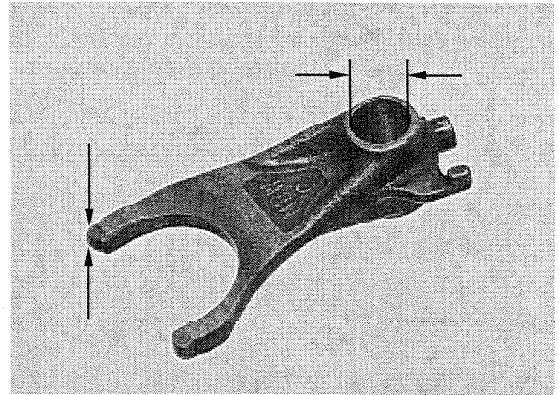

Measure the shift fork shaft O.D.

SERVICE LIMIT: 11.95 mm (0.470 in)

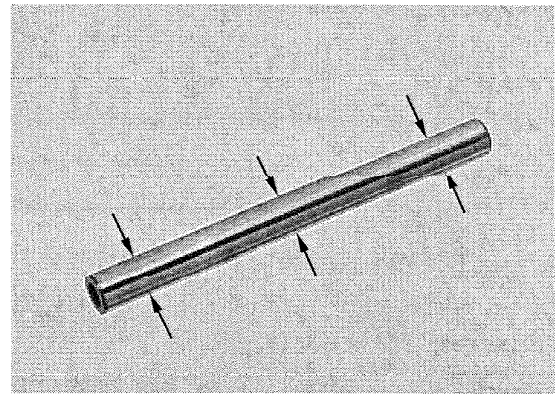

Check the shift drum guide groove for abnormal wear or damage.

Check the shift drum bearing for smooth rotation.

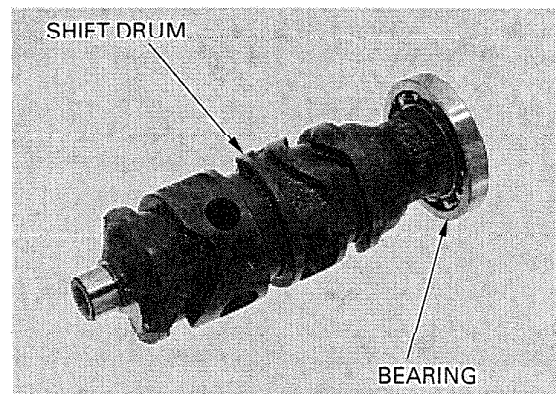

INSTALLATION

Install the shift drum and bearing into the lower crankcase.

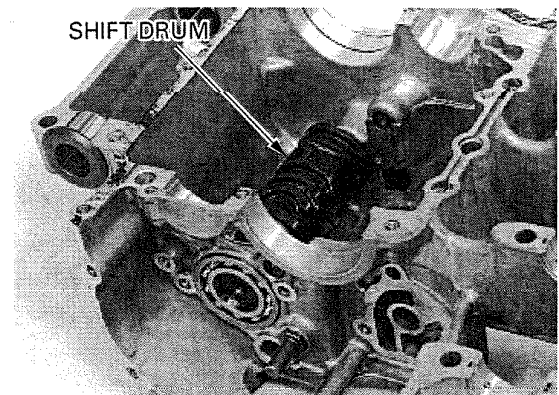

CRANKCASE/TRANSMISSION

The shift forks have the following identification marks:

RL: right and left shift forks
C: center shift fork

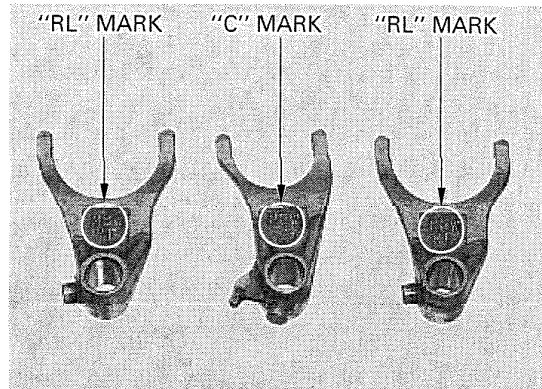

Install the shift forks into the shift drum guide groove with the identification marks facing toward the right side of the engine and insert the fork shaft.

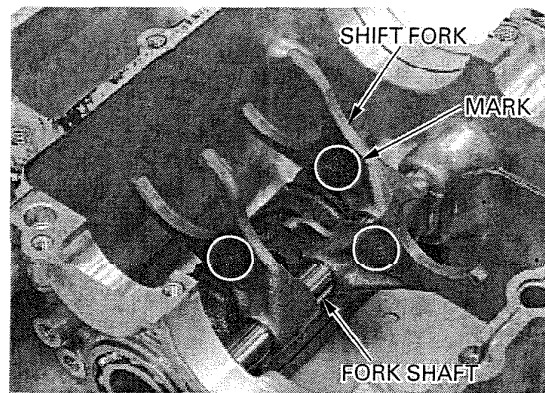

Apply locking agent to the bearing set bolt threads. Install the set bolts and tighten them.

TORQUE : 12 N·m (1.2 kgf·m , 9 lbf·ft)

Assemble the crankcase halves (page 11-11).

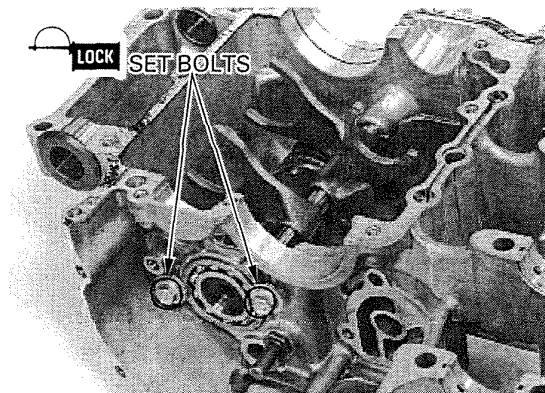

TRANSMISSION

DISASSEMBLY

Separate the crankcase halves (page 11-3).

Remove the mainshaft and countershaft assemblies.

Disassemble the mainshaft and countershaft.

Clean all disassembled parts in solvent thoroughly.

Check the mainshaft and countershaft needle bearings for abnormal wear or damage.

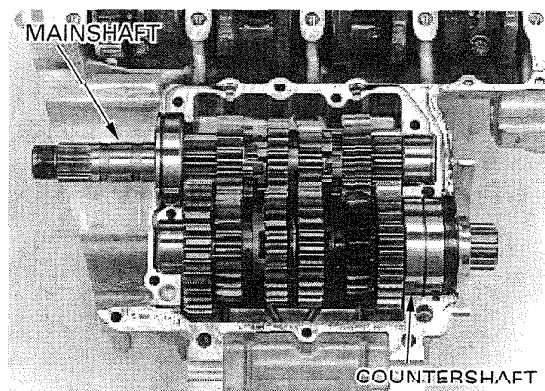

INSPECTION

Check the gear shifter groove for abnormal wear or damage.

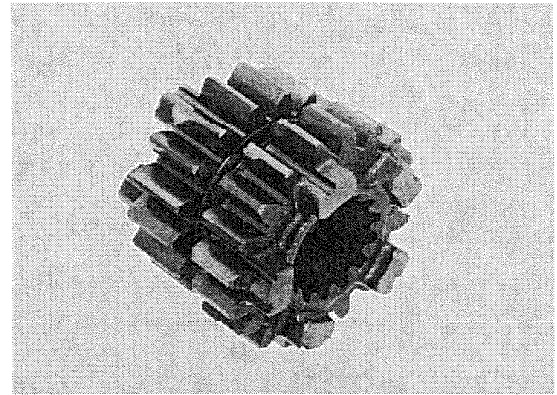

Check the gear dogs and teeth for abnormal wear or damage.

Measure the gear I.D.

SERVICE LIMITS:

M5, M6: 28.04 mm (1.104 in)
C2, C3, C4: 31.04 mm (1.222 in)

Measure the gear bushing O.D.

SERVICE LIMITS:

M5, M6: 27.94 mm (1.100 in)
C3, C4: 30.93 mm (1.218 in)
C2: 30.94 mm (1.210 in)

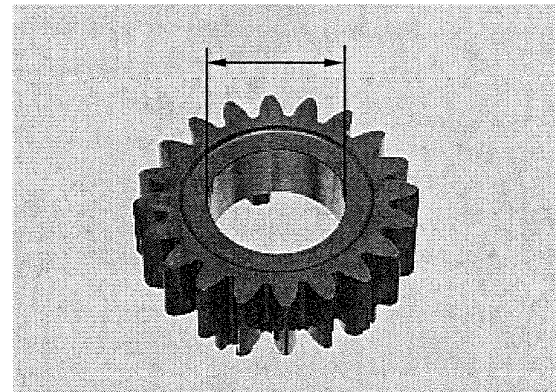

Calculate the gear-to-bushing clearance.

SERVICE LIMITS:

M5, M6: 0.10 mm (0.004 in)
C3, C4: 0.11 mm (0.004 in)
C2: 0.10 mm (0.004 in)

Measure the gear bushing I.D.

SERVICE LIMITS:

M5: 25.016 mm (0.9849 in)
C2: 28.021 mm (1.1032 in)

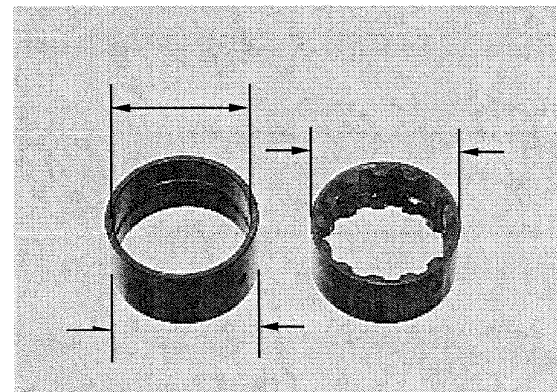

Check the mainshaft and countershaft for abnormal wear or damage.

Measure the mainshaft O.D. at the M5 gear.

SERVICE LIMIT: 24.96 mm (0.983 in)

Measure the countershaft O.D. at the C2 gear.

SERVICE LIMIT: 27.96 mm (1.101 in)

Calculate the gear bushing-to-shaft clearance.

SERVICE LIMITS:

M5: 0.06 mm (0.002 in)
C2: 0.06 mm (0.002 in)

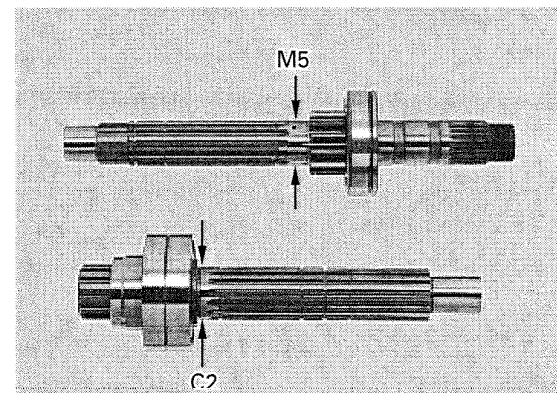

CRANKCASE/TRANSMISSION

Turn the ball bearing outer race with your finger. The bearing should turn smoothly and quietly. Also check that the bearing inner race fits tightly on the shaft.

Replace the bearing if the outer race does not turn smoothly, quietly, or if the inner race fits loosely on the shaft.

NOTE:

The countershaft ball bearing cannot be replaced. If the countershaft bearing is faulty, replace the countershaft.

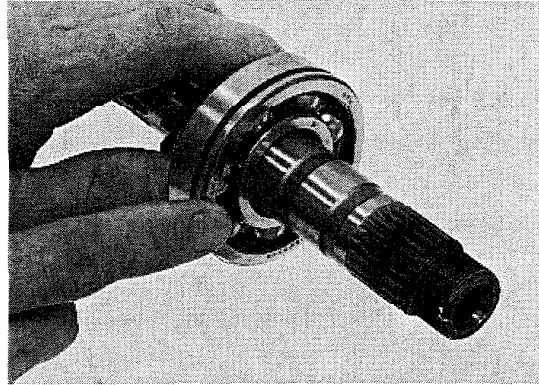

MAINSHAFT BEARING REPLACEMENT

Press the mainshaft out of the bearing.

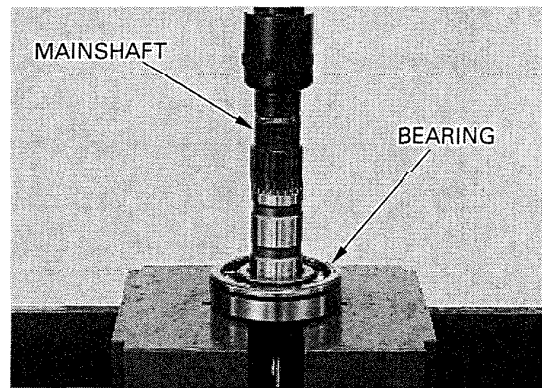

Install with the groove side facing up.

Press a new bearing onto the mainshaft with the special tools.

TOOL:

Inner driver C 07746-0030100
Attachment, 25 mm I.D. 07746-0030200

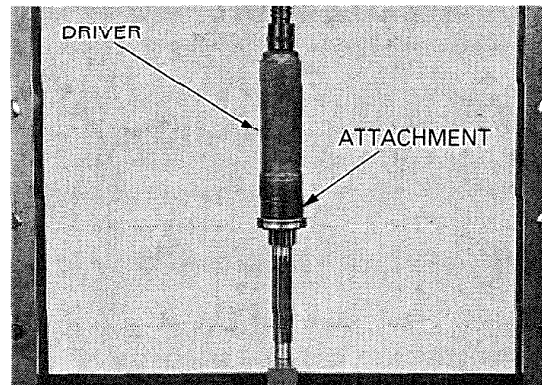

ASSEMBLY

Apply molybdenum oil solution to the gear teeth, sliding surface, shifter grooves and bushings.

Assemble the mainshaft and countershaft.

MAINSHAFT:

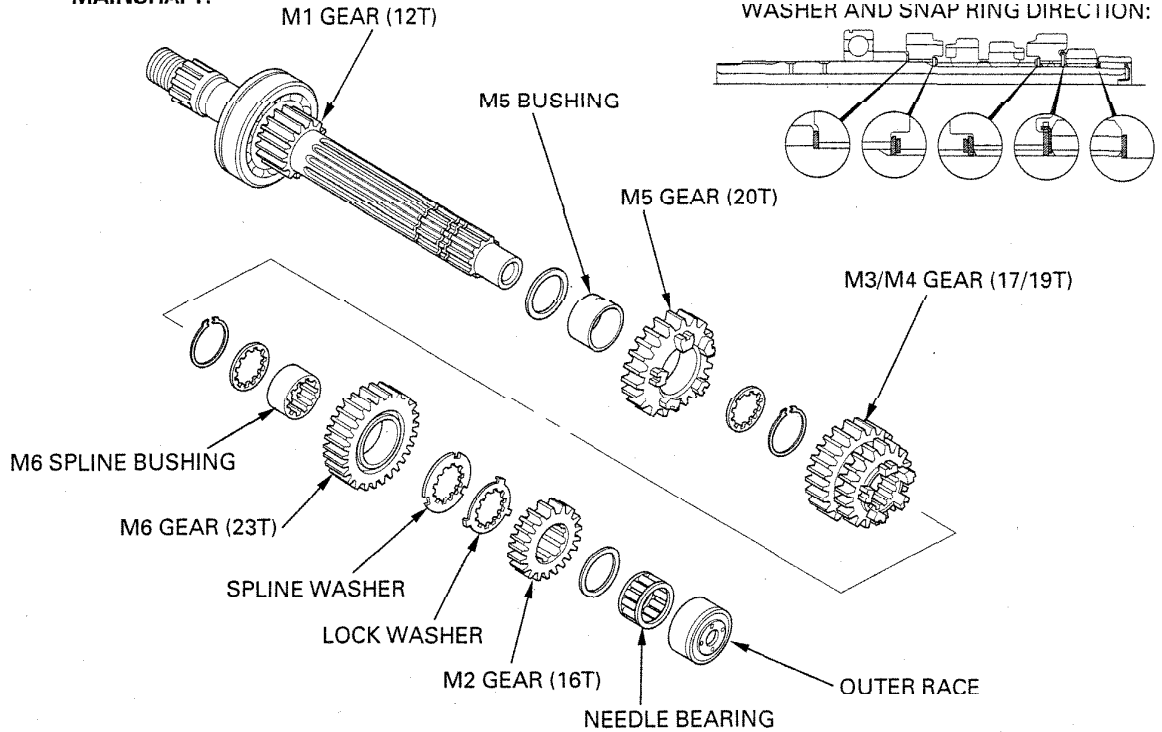

COUNTERSHAFT:

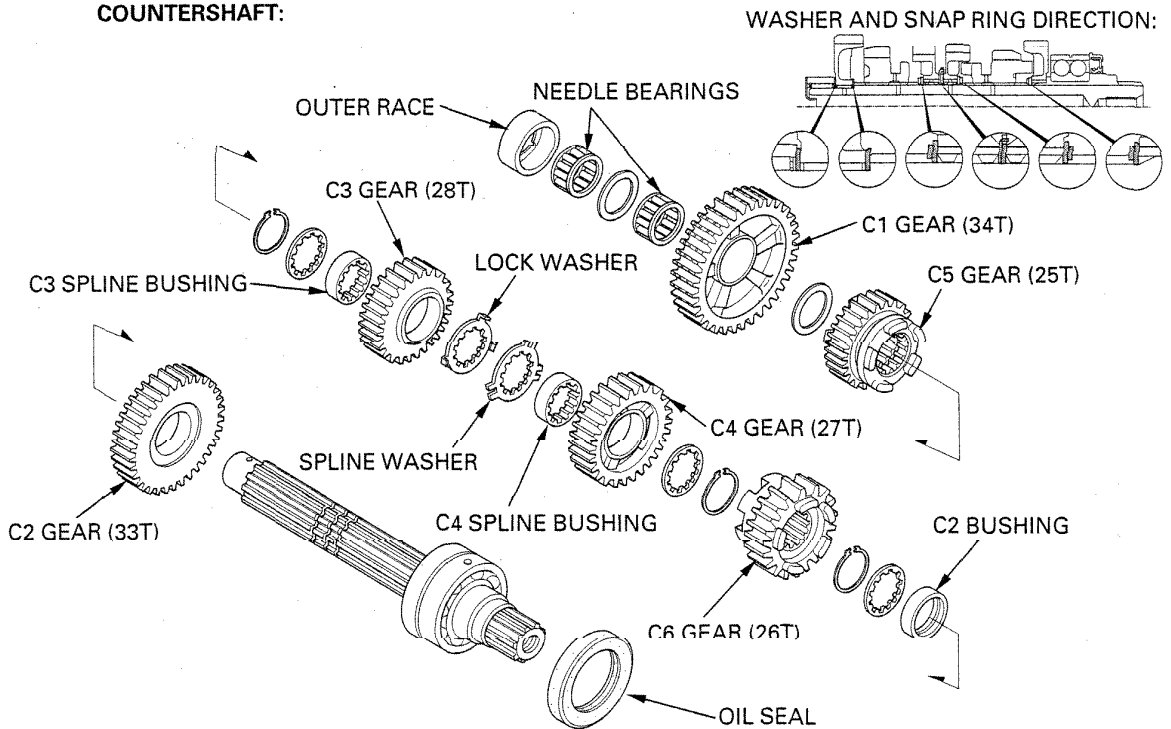

CRANKCASE/TRANSMISSION

NOTE:

Align the oil holes in the M6 bushing and mainshaft, and the C3, C4 spline bushings and countershaft.

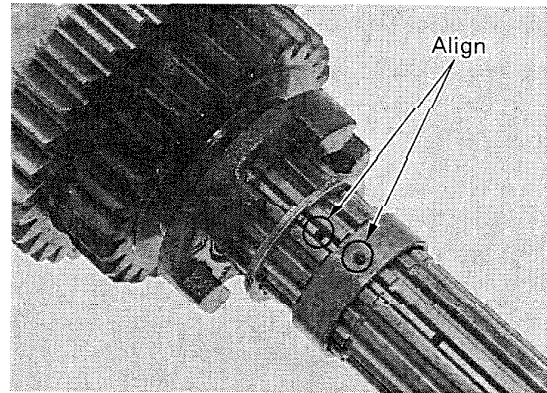

NOTE:

- Align the lock washer tabs with the spline washer grooves.
- Always install the thrust washer and snap ring with the chamfered (rolled) edge facing away from the thrust load.
- Install the snap ring so that its end gap aligns with the groove in the splines.
- Make sure that the snap ring is fully seated in the shaft groove after installing it.

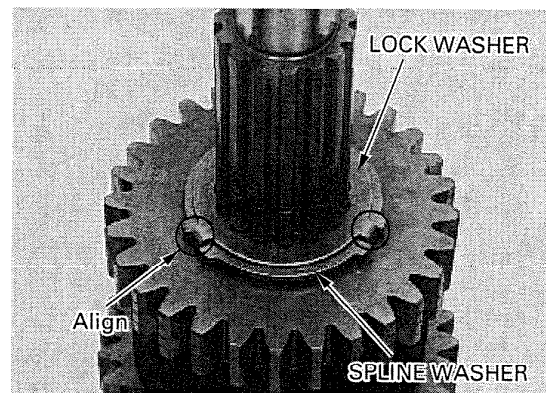

Install the mainshaft assembly by aligning the hole in the needle bearing outer race with the dowel pin.

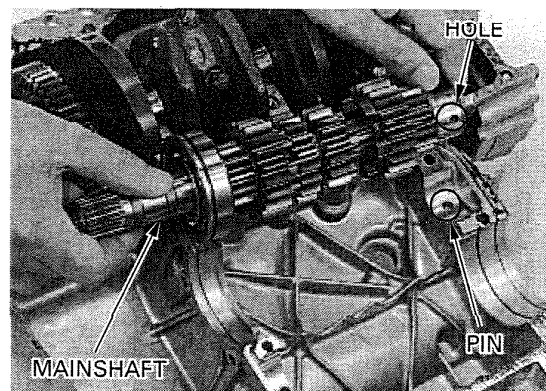

Install the countershaft assembly by aligning the hole in the needle bearing outer race with the dowel pin, and the ring groove with the set ring.

Rest the pin on the ball bearing into the pin groove.

Assemble the crankcase halves (page 11-11).

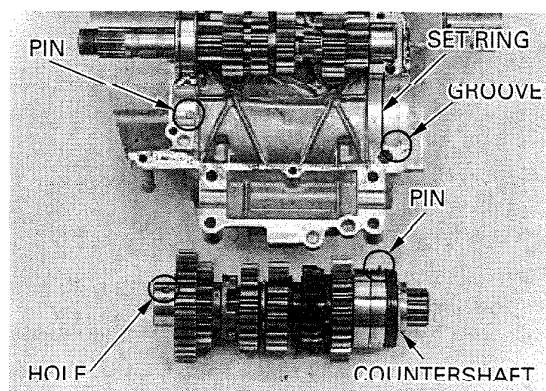

CRANKCASE ASSEMBLY

Apply sealant to the crankcase mating surfaces as shown.

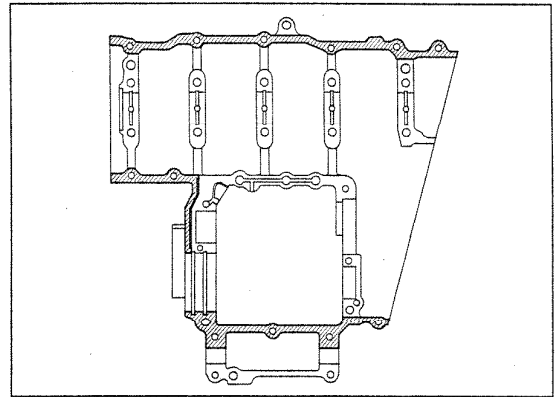

Install the three dowel pins and the two oil orifices by aligning the flat surfaces.

Apply molybdenum oil solution to the main journal bearing surfaces on the lower crankcase. Install the lower crankcase onto the upper crankcase, aligning the shift forks with the gear shifter grooves.

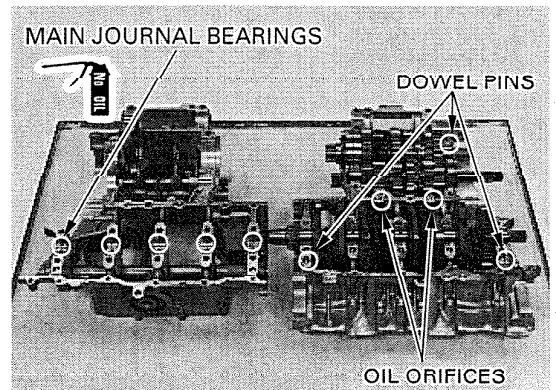

Apply engine oil to the 8 mm bolt threads and seating surfaces. Install the 10 mm bolt, ten 8 mm bolts and eight 6 mm bolts and tighten them in a crisscross pattern in 2 or 3 steps.

TORQUE: 10 mm bolt: 39 N·m (4.0 kgf·m , 29 lbf·ft)
8 mm bolt: 25 N·m (2.6 kgf·m , 19 lbf·ft)

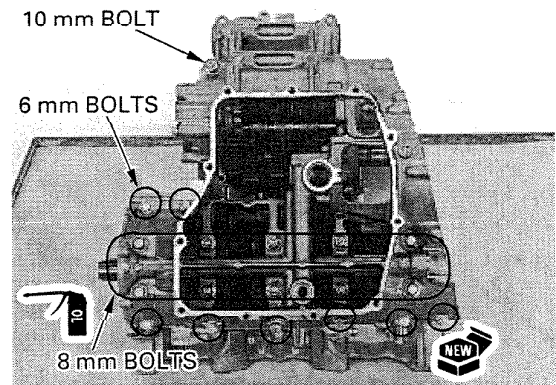

Install the sealing washers indicated by the "Δ" marks.

Install the five 8 mm bolts and seven 6 mm bolts with new sealing washers. Tighten the bolts in a crisscross pattern in 2 or 3 steps.

TORQUE: 8 mm bolt: 25 N·m (2.5 kgf·m , 18 lbf·ft)

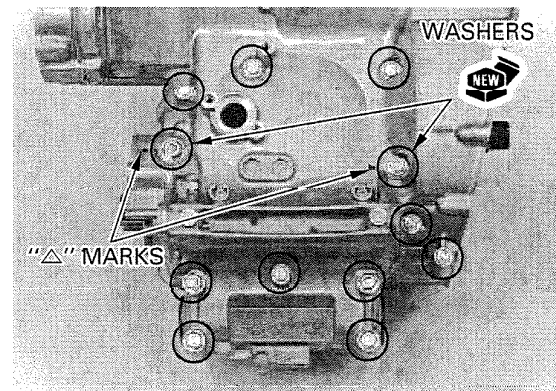

CRANKCASE/TRANSMISSION

Apply locking agent to the set plate bolt threads.
Install the bearing set plate with "OUT SIDE" mark facing out and tighten the three bolts.

TORQUE : 12 N·m (1.2 kgf·m , 9 lbf·ft)

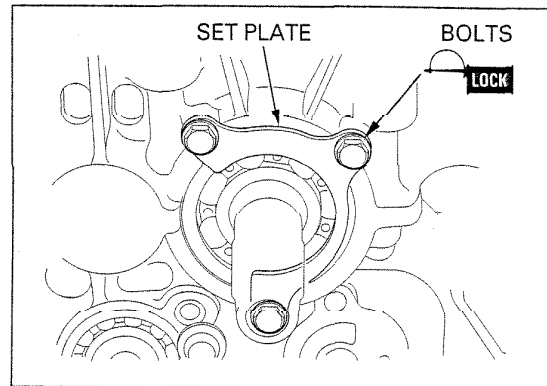

Install the timing sprocket and the ignition pulse generator rotor, aligning the wide groove with the wide tooth.
Install the bolt with the washer and tighten it.

TORQUE : 59 N·m (6.0 kgf·m , 43 lbf·ft)

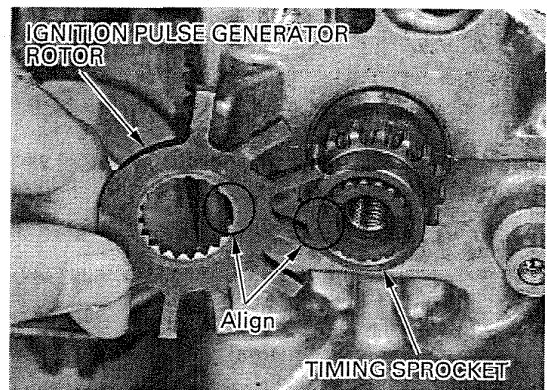

Install the cam chain.
Apply locking agent to the pivot bolt threads.
Install the cam chain tensioner, washer (between the tensioner and crankcase) and pivot bolt.
Tighten the bolt.

TORQUE : 10 N·m (1.0 kgf·m , 7 lbf·ft)

Install the cam chain guide and washer bolt.
Tighten the bolt.

TORQUE : 12 N·m (1.2 kgf·m , 9 lbf·ft)

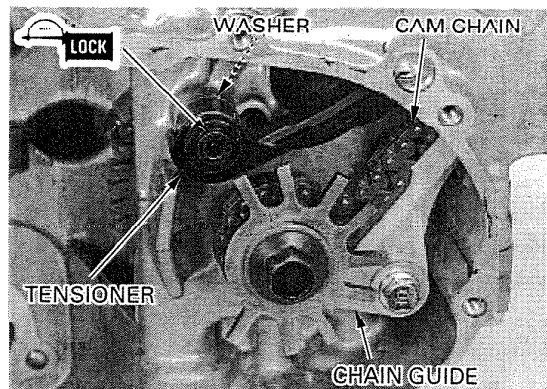

Install a new O-ring into the groove in the water hose joint.
Install the hose joint with the spout facing down and tighten the bolts.

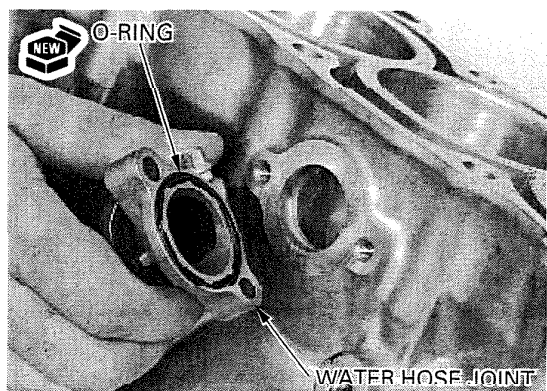

CRANKCASE/TRANSMISSION

Coat a new O-ring with oil and install it onto the speed sensor.
Install the speed sensor and tighten the bolts.

Install the following:

- oil pressure switch (page 4-3)
- oil pump, oil cooler, oil strainer, pressure relief valve and oil pan (section 4)
- water pump (section 6)
- starter motor (section 18)
- flywheel (section 10)
- gearshift linkage and clutch (section 9)
- cylinder head, camshafts and head cover (section 8)
- engine (section 7)

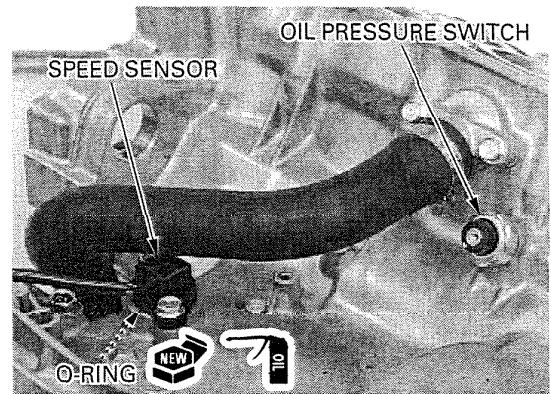

CRANKSHAFT/PISTON/CYLINDER

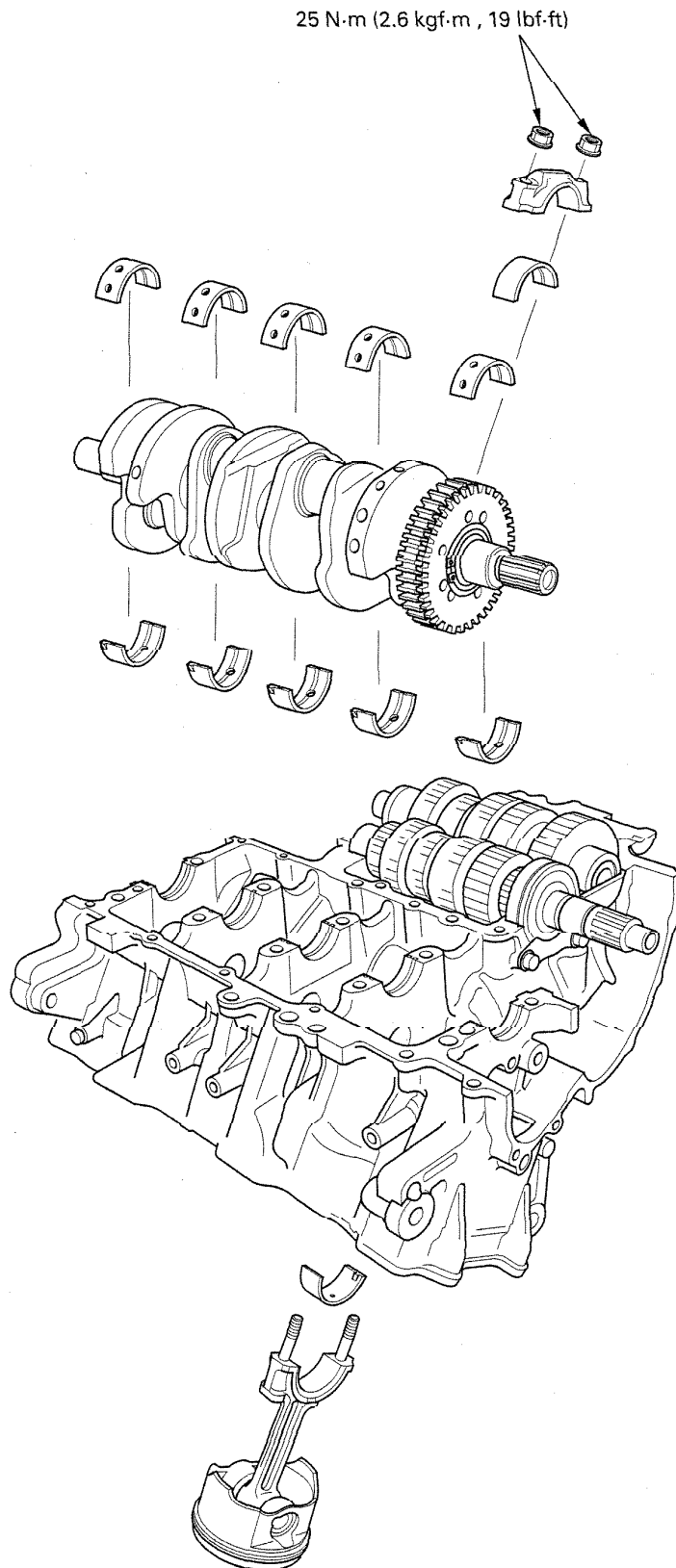

12. CRANKSHAFT/PISTON/CYLINDER

SERVICE INFORMATION	12-1	MAIN JOURNAL BEARING	12-6
TROUBLESHOOTING	12-2	CRANKPIN BEARING	12-8
CRANKSHAFT	12-3	PISTON/CYLINDER	12-10

SERVICE INFORMATION

GENERAL

- The crankcase must be separated to service the crankshaft and piston/connecting rod. Refer to section 11 for crankcase separation and assembly.
- Mark and store the connecting rods, bearing caps, pistons and bearing inserts to be sure of their correct locations for reassembly.
- The crankpin and main journal bearing inserts are select fit and are identified by color codes. Select replacement bearings from the code tables. After selecting new bearings, recheck the oil clearance with a plastigauge. Incorrect oil clearance can cause major engine damage.

SPECIFICATIONS

Unit: mm (in)

ITEM		STANDARD	SERVICE LIMIT	
Crankshaft	Connecting rod side clearance	0.10 – 0.25 (0.004 – 0.010)	0.30 (0.012)	
	Crankpin bearing oil clearance	0.028 – 0.052 (0.0011 – 0.0020)	0.06 (0.002)	
	Main journal bearing oil clearance	0.020 – 0.038 (0.0008 – 0.0015)	0.05 (0.002)	
	Runout	—————	0.05 (0.002)	
Piston, piston pin, piston ring	Piston O.D. at 15 (0.6) from bottom	66.965 – 66.985 (2.6364 – 2.6372)	66.90 (2.634)	
	Piston pin hole I.D.	17.002 – 17.008 (0.6694 – 0.6696)	17.02 (0.670)	
	Piston pin O.D.	16.994 – 17.000 (0.6691 – 0.6693)	16.98 (0.669)	
	Piston-to-piston pin clearance	0.002 – 0.014 (0.0001 – 0.0006)	0.04 (0.002)	
	Piston ring end gap	Top	0.10 – 0.20 (0.004 – 0.008)	0.4 (0.02)
		Second	0.18 – 0.30 (0.007 – 0.012)	0.5 (0.02)
		Oil (side rail)	0.2 – 0.7 (0.01 – 0.03)	1.0 (0.04)
	Piston ring-to-ring groove clearance	Top	0.020 – 0.050 (0.0008 – 0.0020)	0.08 (0.003)
Second		0.015 – 0.050 (0.0006 – 0.0020)	0.08 (0.003)	
Cylinder	I.D.	67.000 – 67.015 (2.6378 – 2.6384)	67.10 (2.642)	
	Out of round	—————	0.10 (0.004)	
	Taper	—————	0.10 (0.004)	
	Warpage	—————	0.10 (0.004)	
Cylinder-to-piston clearance		0.015 – 0.050 (0.0006 – 0.0020)	0.10 (0.004)	
Connecting rod small end I.D.		17.016 – 17.034 (0.6699 – 0.6706)	17.04 (0.671)	
Connecting rod-to-piston pin clearance		0.016 – 0.040 (0.0006 – 0.0016)	0.06 (0.002)	

CRANKSHAFT/PISTON/CYLINDER

TORQUE VALUES

Connecting rod bearing cap nut	25 N·m (2.6 kgf·m , 19 lbf·ft)	Apply oil to the threads and seating surface
Crankcase bolt (Main journal)	25 N·m (2.6 kgf·m , 19 lbf·ft)	Apply oil to the threads and seating surface

TOOLS

Inner driver C	07746-0030100
Attachment, 30 mm I.D.	07746-0030300
Universal bearing puller	07631-0010000

TROUBLESHOOTING

Compression too low, hard starting or poor performance at low speed

- Leaking cylinder head gasket
- Worn, stuck or broken piston ring
- Worn or damaged cylinder and piston

Compression too high, overheating or knocking

- Excessive carbon built-up on piston head or combustion chamber

Excessive smoke

- Worn cylinder, piston or piston rings
- Improper installation of piston rings
- Scored or scratched piston or cylinder wall

Abnormal noise

- Worn piston pin or piston pin hole
- Worn connecting rod small end
- Worn cylinder, piston or piston rings
- Worn main journal bearings
- Worn crankpin bearings

CRANKSHAFT

Separate the crankcase halves (page 11-3).

SIDE CLEARANCE INSPECTION

Measure the connecting rod side clearance.

SERVICE LIMIT: 0.30 mm (0.012 in)

If the clearance exceeds the service limit, replace the connecting rod.

Recheck and if it is still out of limit, replace the crankshaft.

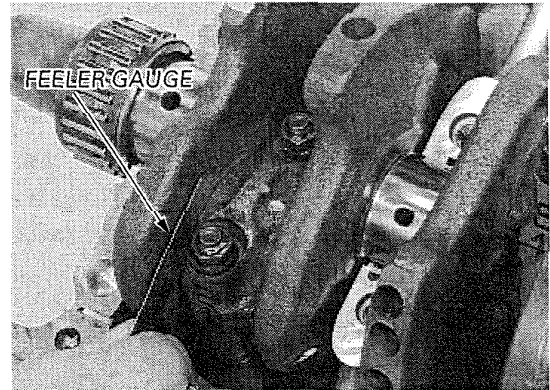

REMOVAL

CAUTION:

Be careful not to damage the crankpin, main journal and bearing inserts.

NOTE:

- Mark the bearing caps and bearings as you remove them to indicate the correct cylinder for re-assembly.
- Tap the side of the cap lightly if the bearing cap is hard to removed.

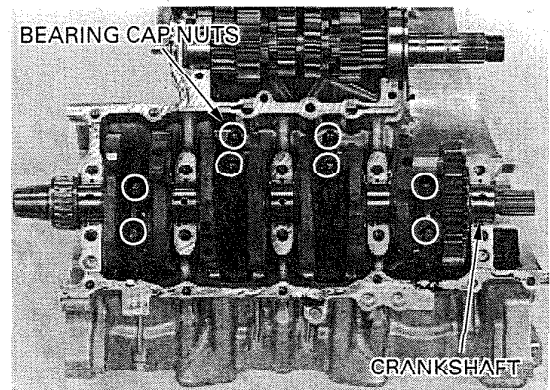

Remove the connecting rod bearing cap nuts and bearing caps.

Lower the pistons to the top dead center to avoid damaging the crankshaft by the connecting rod bolts.

Remove the crankshaft.

INSPECTION

Hold the crankshaft both end.

Set a dial indicator on the center main journal of the crankshaft.

Rotate the crankshaft two revolutions and read the runout.

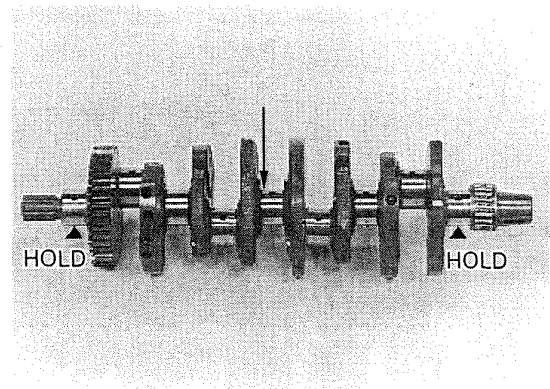

SERVICE LIMIT. 0.05 mm (0.002 in)

Check the primary drive gear and sub-gear teeth for abnormal wear or damage.

SUB-GEAR REMOVAL/INSTALLATION

Remove the following:

- snap ring
- cone spring
- sub-gear
- gear springs
- stopper pins

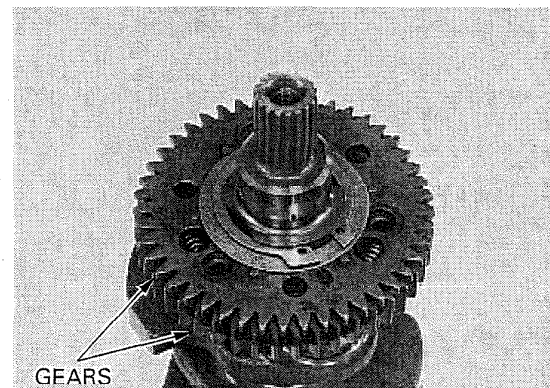

CRANKSHAFT/PISTON/CYLINDER

Install the stopper pins and gear springs onto the primary drive gear as shown.

Apply molybdenum oil solution to the sub-gear sliding surface.

Temporarily install the sub-gear by aligning the punch mark with the hole in the primary drive gear.

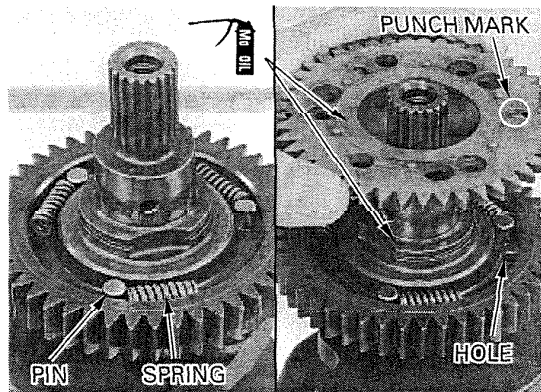

Install the cone spring onto the sub-gear.

Install the sub-gear onto the primary drive gear so that it evenly touches the primary drive gear by prying the sub-gear with a 5 mm pin or screwdriver while the stoppers on the reverse side of the sub-gear are pushing against the gear springs.

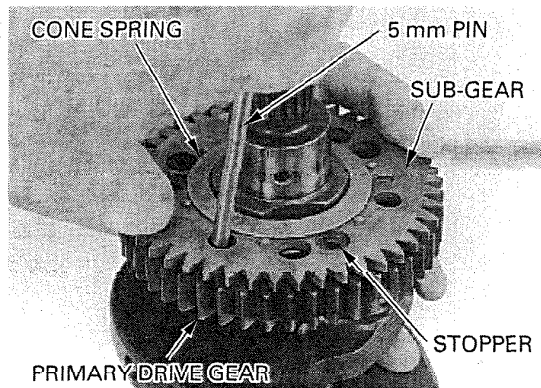

Install with the large tab facing the right and the chamfered side facing the gear.

Install a new snap ring into the ring groove in the crankshaft securely with the end gap at right angle to the crankshaft cut-outs by aligning the large tab edge with the sub-gear groove as shown.

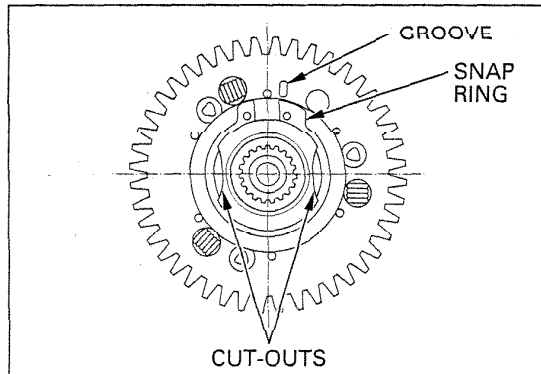

STARTER CLUTCH NEEDLE BEARING REPLACEMENT

Remove the needle bearing with the bearing puller.

TOOL:

Universal bearing puller 07631-0010000

CAUTION:

To protect the crankshaft main journal from the bearing puller claws, cover the mainshaft journal properly; worn main journal bearings are usable as protectors.

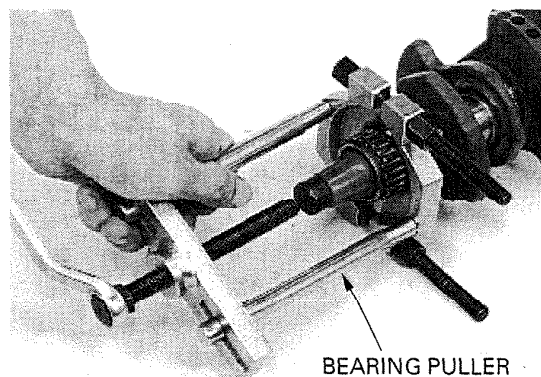

Press with the bearing's marked side facing up. Press a new needle bearing onto the crankshaft using the special tools until its edge is flush with the groove in the crankshaft. Make sure that the height from the crankshaft end is 27.6–27.9 mm (1.09–1.10 in).

TOOLS:

Inner driver C 07746-0030100
Attachment, 30 mm I.D. 07746-0030300

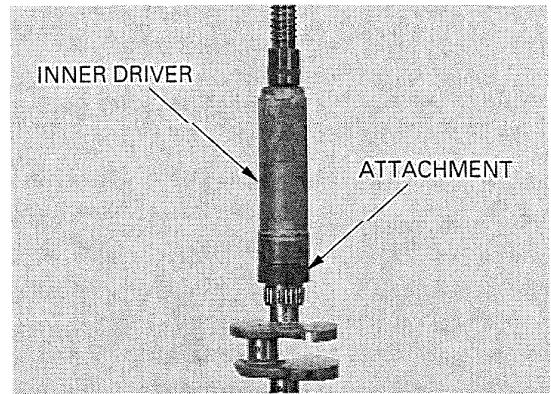
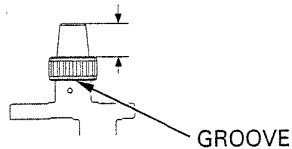

INSTALLATION

CAUTION:

Do not get the molybdenum oil solution to the connecting rod bolts and bearing cap nuts. It may cause the cap nuts to be tightened to an incorrect torque value.

Apply molybdenum oil solution to the main journal bearing sliding surfaces on the upper crankcase and the crankpin bearing sliding surfaces on the connecting rods.

Apply molybdenum oil solution to the thrust surfaces of the crankshaft as shown.

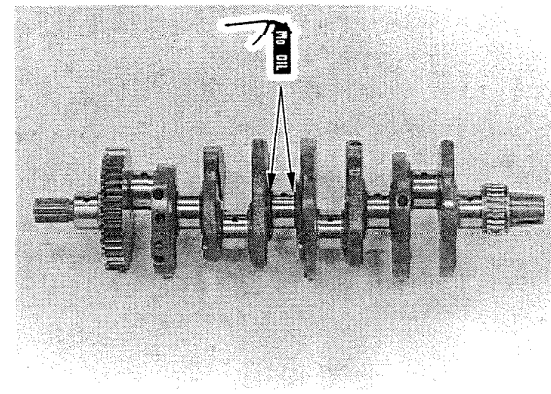
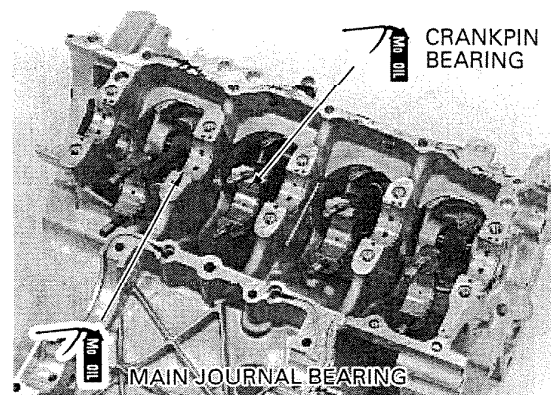

Lower all the pistons to the top dead center to avoid damaging the crankpin by the connecting rod bolts. Carefully install the crankshaft onto the upper crankcase. Set the connecting rods onto the crankpins.

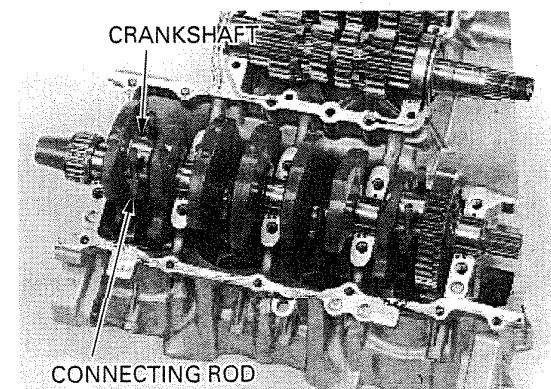

CRANKSHAFT/PISTON/CYLINDER

Apply molybdenum oil solution to the crankpin bearing sliding surfaces on the bearing caps. Install the bearing caps by aligning the I.D. code on the connecting rod and bearing cap. Be sure each part is installed in its original position, as noted during removal.

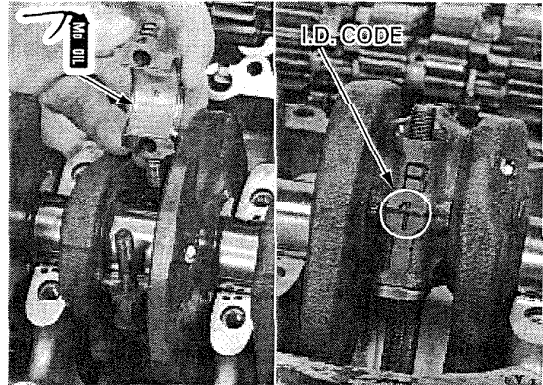

Apply engine oil to the bearing cap nut threads and seating surfaces and install the cap nuts. Tighten the nuts in 2 or 3 steps.

TORQUE : 25 N·m (2.6 kgf·m , 19 lbf·ft)

Assemble the crankcase halves (page 11-11).

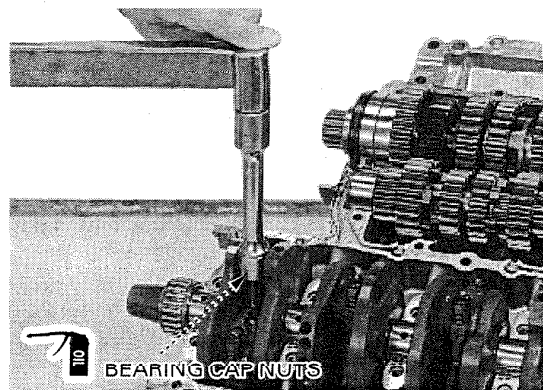

MAIN JOURNAL BEARING

Remove the crankshaft (page 12-3).

BEARING INSPECTION

Check the bearing inserts on the upper and lower crankcases for unusual wear or peeling. Check the bearing tabs for damage.

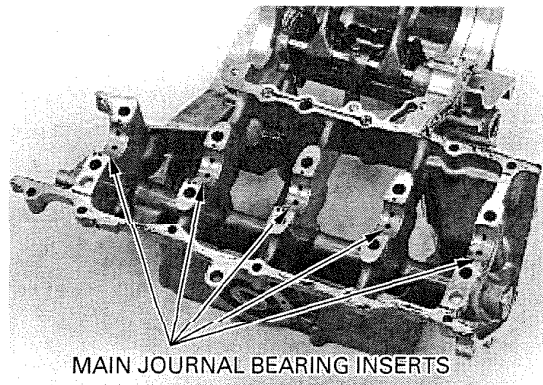

OIL CLEARANCE INSPECTION

Do not rotate the crankshaft during inspection.

Clean off any oil from the bearing inserts and main journals. Install the crankshaft onto the upper crankcase. Put a strip of plastigauge lengthwise on each main journal avoiding the oil hole.

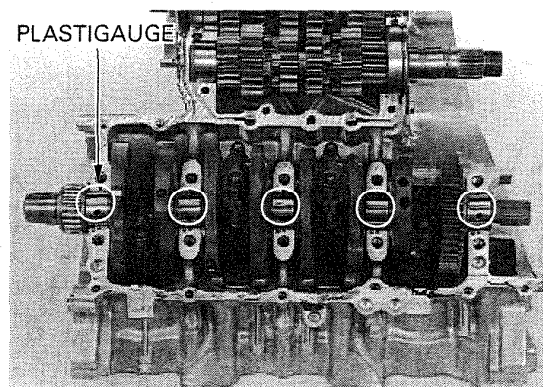

CRANKSHAFT/PISTON/CYLINDER

Install the dowel pins and oil orifices.
Carefully install the lower crankcase on the upper crankcase.
Apply engine oil to the main journal 8 mm bolt threads and seating surfaces and install them.
Tighten the bolts in a crisscross pattern in 2 or 3 steps.

TORQUE : 25 N·m (2.6 kgf·m , 19 lbf·ft)

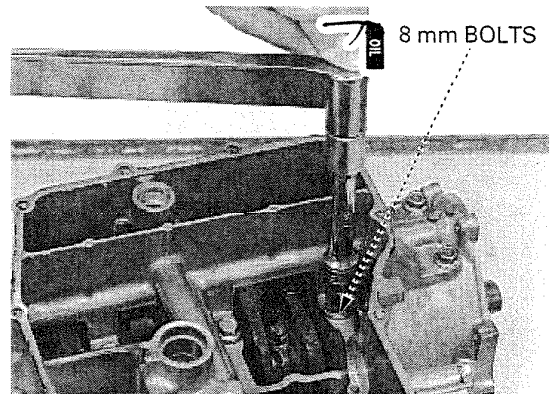

Remove the lower crankcase and measure the compressed plastigauge at its widest point on each main journal to determine the oil clearance.

SERVICE LIMIT: 0.05 mm (0.002 in)

If the oil clearance exceeds the service limit, select the correct replacement bearings.

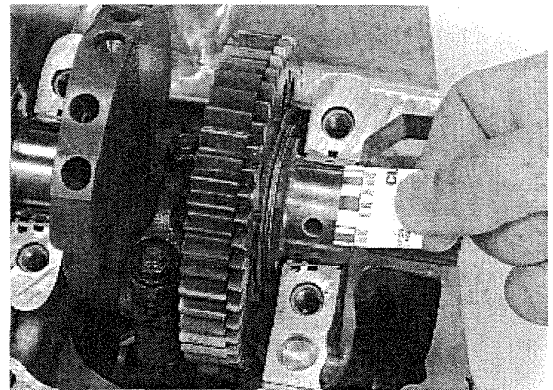

BEARING SELECTION

Record the crankcase bearing support I.D. code letters.

NOTE:

Letters (A, B or C) on the left side of upper crankcase are the codes for the bearing support I.D. s from left to right.

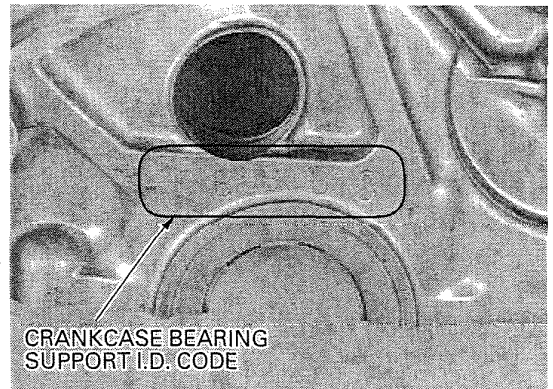

Record the corresponding main journal O.D. code numbers.

NOTE:

Numbers (1, 2 or 3) on the crank weight are the codes for the main journal O.D. e from left to right.

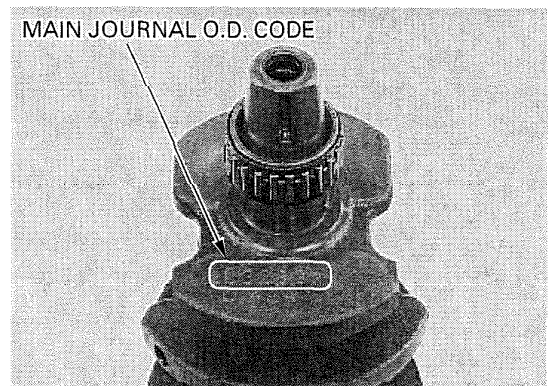

CRANKSHAFT/PISTON/CYLINDER

Cross reference the main journal and bearing support codes to determine the replacement bearing color code.

Bearing support I.D. code Main journal O.D. code		Unit: mm (in)		
		A	B	C
		33.000–33.006 (1.2992–1.2994)	33.006–33.012 (1.2994–1.2997)	33.012–33.018 (1.2997–1.2999)
1	30.000–30.006 (1.1811–1.1813)	E (Pink)	D (Yellow)	C (Green)
2	29.994–30.000 (1.1809–1.1811)	D (Yellow)	C (Green)	B (Brown)
3	29.988–29.994 (1.1806–1.1809)	C (Green)	B (Brown)	A (Black)

MAIN JOURNAL BEARING INSERT THICKNESS:

A: Black: 1.506–1.509 mm (0.0593–0.0594 in)
 B: Brown: 1.503–1.506 mm (0.0592–0.0593 in)
 C: Green: 1.500–1.503 mm (0.0591–0.0592 in)
 D: Yellow: 1.497–1.500 mm (0.0589–0.0591 in)
 E: Pink: 1.494–1.497 mm (0.0588–0.0589 in)

CAUTION:

After selecting new bearings, recheck the oil clearance with plastigauge. Incorrect oil clearance can cause major engine damage.

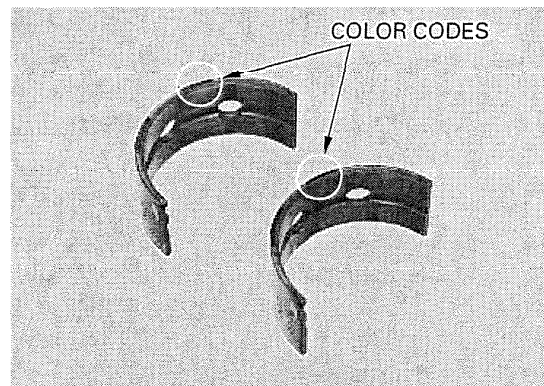

BEARING INSTALLATION

Clean the bearing outer surfaces and crankcase bearing supports.
 Install the main journal bearing inserts onto the crankcase bearing supports, aligning each tab with each groove.

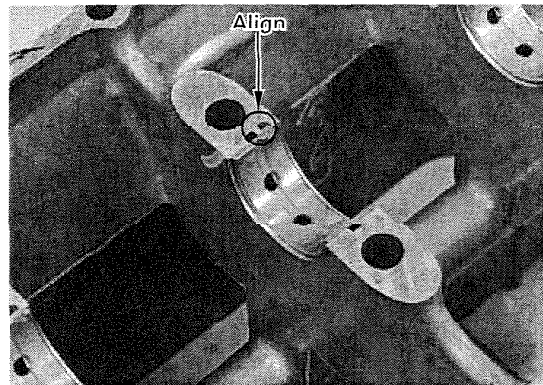

CRANKPIN BEARING

Remove the crankshaft (page 12-3).

BEARING INSPECTION

Check the bearing inserts for unusual wear or damage.
 Check the bearing tabs for damage.



OIL CLEARANCE INSPECTION

Do not rotate the crankshaft during inspection.

Clean off any oil from the bearing inserts and crankpin.
Carefully install the crankshaft onto the upper crankcase.
Set the connecting rods onto the crankpin.
Put a strip of plastigauge lengthwise on the crankpin avoiding the oil hole.

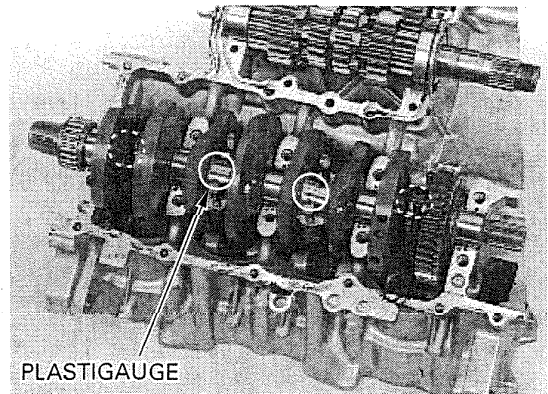

Carefully install the bearing caps by aligning the I.D. code.
Apply engine oil to the connecting rod bearing cap nut threads and seating surfaces and install them.
Tighten the cap nuts in 2 or 3 steps.

TORQUE : 25 N·m (2.6 kgf·m , 19 lbf·ft)

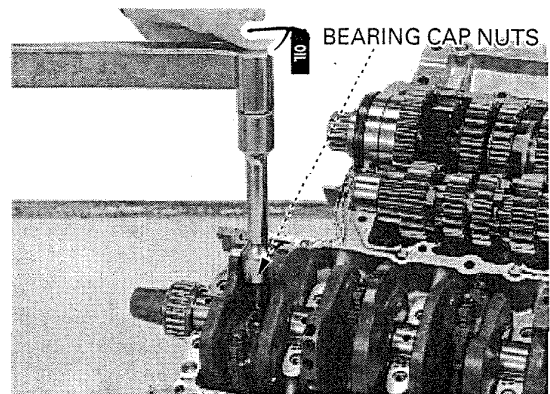

Remove the bearing caps and measure the compressed plastigauge at its widest point on the crankpin to determine the oil clearance.

SERVICE LIMIT: 0.06 mm (0.002 in)

If the oil clearance exceeds the service limit, select the correct replacement bearings.

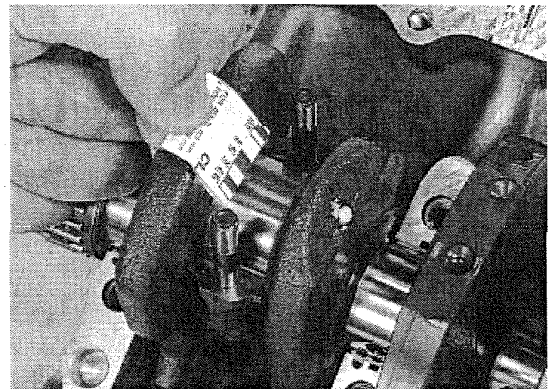

BEARING SELECTION

Record the connecting rod I.D. code numbers.

NOTE:

Numbers (1 or 2) on the connecting rods are the codes for the connecting rod I.D.

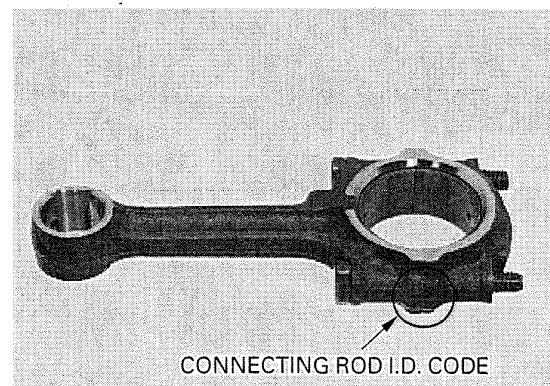

CRANKSHAFT/PISTON/CYLINDER

Record the crankpin O.D. code letters.

NOTE:

Letters (A or B) on the crank weight are the codes for the crankpin O.D. s from left to right.

CRANK PIN O.D. CODE

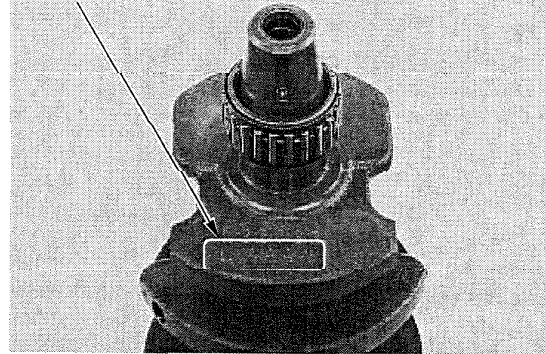

Cross reference the connecting rod and crankpin codes to determine the replacement bearing color code.

		Unit: mm (in)			
Connecting rod I.D. code		1		2	
Crankpin O.D. code		34.000 (1.3386 – 1.3389)	34.000 (1.3389 – 1.3392)	34.000 (1.3389 – 1.3392)	34.010 (1.3392 – 1.3395)
A	31.492 – 31.500 (1.2398 – 1.2402)	Yellow		Green	
B	31.484 – 31.492 (1.2395 – 1.2398)	Green		Brown	

COLOR CODES

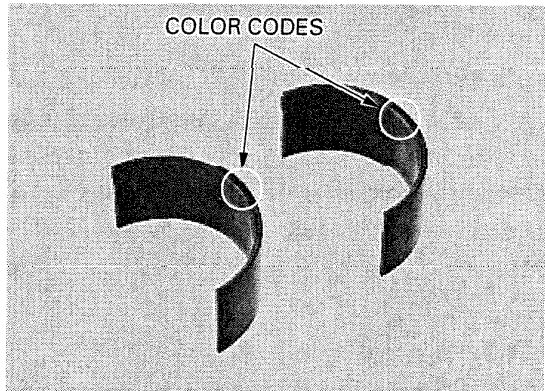

CRANKPIN BEARING INSERT THICKNESS:

Brown: 1.244 – 1.248 mm (0.0490 – 0.0491 in)

Green: 1.240 – 1.244 mm (0.0488 – 0.0490 in)

Yellow: 1.236 – 1.240 mm (0.0487 – 0.0488 in)

CAUTION:

After selecting new bearings, recheck the oil clearance with plastigauge. Incorrect oil clearance can cause major engine damage.

BEARING INSTALLATION

Clean the bearing outer surfaces, bearing cap and connecting rod.

Install the crankpin bearing inserts onto the bearing cap and connecting rod, aligning each tab with each groove.

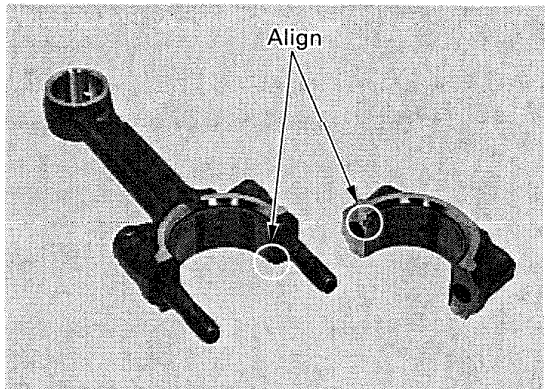

PISTON/CYLINDER

CAUTION:

Be careful not damage main journal and crankpin bearing inserts.

NOTE:

Mark the all the parts as you remove them to indicate the correct cylinder for reassembly.

PISTON REMOVAL

Remove the crankshaft (page 12-3).

CRANKSHAFT/PISTON/CYLINDER

Push the connecting rods/pistons out through the top of the cylinder.

CAUTION:

Do not try to remove the connecting rod/piston assembly from the bottom of the cylinder; the assembly will be locked so that the oil ring expands in the gap between the cylinder liner and the upper crankcase.

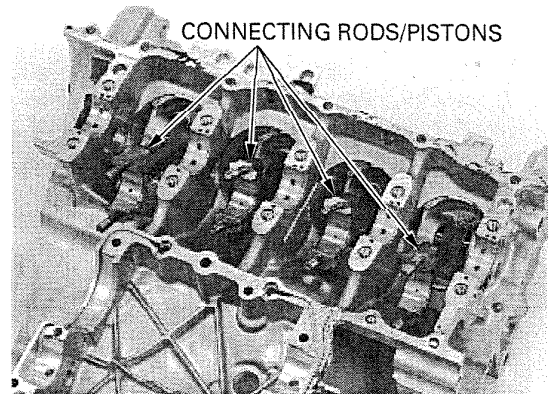

Remove the piston pin clips with the pliers. Push the piston pin out of the piston and connecting rod, and remove the piston.

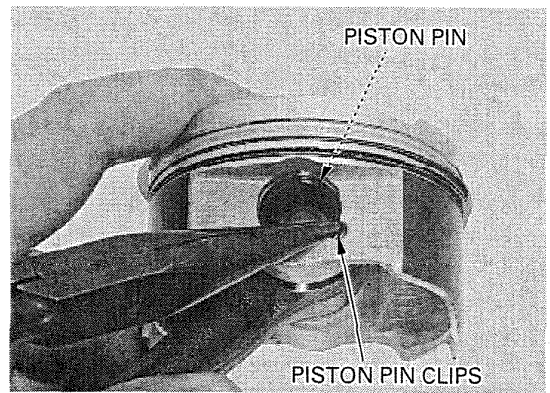

PISTON RING REMOVAL

CAUTION:

Do not damage the piston ring by spreading the ends too far.

Spread each piston ring and remove it by lifting up at a point opposite the gap.

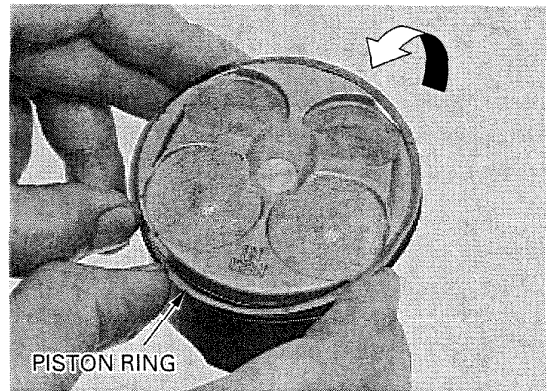

Clean carbon deposits from the piston.

CAUTION:

Clean carbon deposits from the ring grooves with a ring that will be discarded. Never use a wire brush; it will scratch the groove.

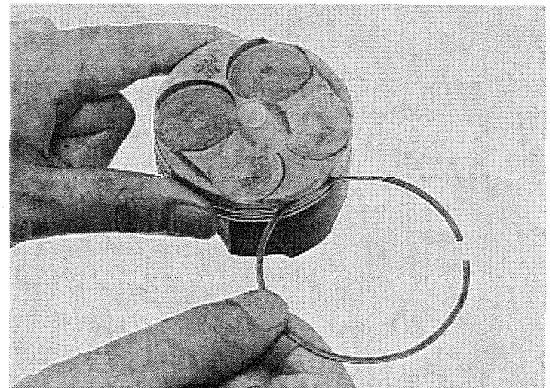

CRANKSHAFT/PISTON/CYLINDER

PISTON INSPECTION

Inspect the piston rings for movement by rotating the rings. The rings should be able to move in their grooves without catching.

Push the ring until the outer surface of the piston ring is nearly flush with the piston and measure the ring-to-ring groove clearance.

SERVICE LIMITS: Top/Second: 0.08 mm (0.003 in)



Insert each piston ring into the bottom of the cylinder squarely using the piston. Measure the ring end gap.

SERVICE LIMITS: Top: 0.4 mm (0.02 in)
Second: 0.5 mm (0.02 in)
Oil (side rail): 1.0 mm (0.04 in)

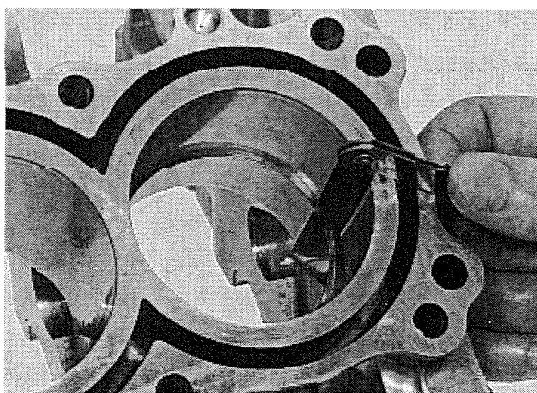

Measure the piston pin O.D. at piston and connecting rod sliding areas.

SERVICE LIMIT: 16.98 mm (0.669 in)

Measure the piston pin hole I.D.

SERVICE LIMIT: 17.02 mm (0.670 in)

Calculate the piston-to-piston pin clearance.

SERVICE LIMIT: 0.04 mm (0.002 in)

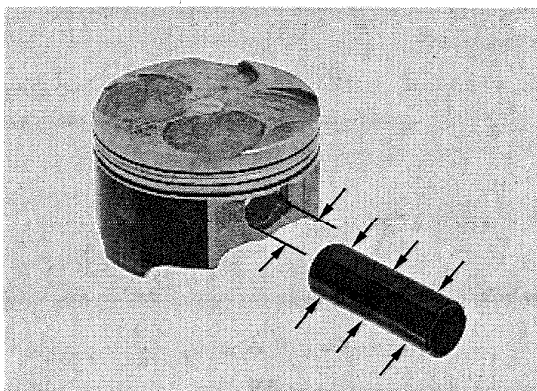

Measure the connecting rod small end I.D.

SERVICE LIMIT: 17.04 mm (0.671 in)

Calculate the connecting rod-to-piston pin clearance.

SERVICE LIMIT: 0.06 mm (0.002 in)

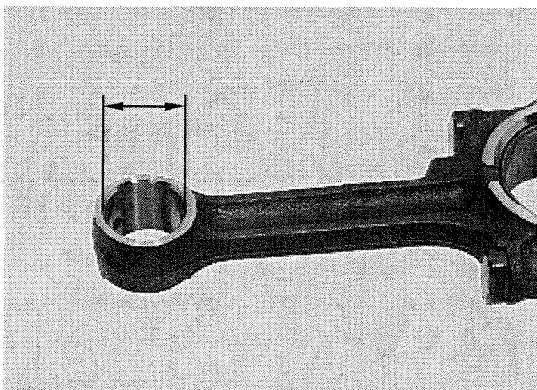

Measure the piston O.D. at a point 15 mm (0.6 in) from the bottom and 90° to the piston pin hole.

SERVICE LIMIT: 66.90 mm (2.634 in)

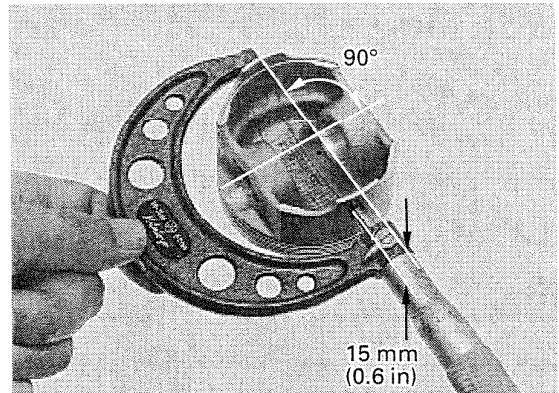

CYLINDER INSPECTION

Inspect the cylinder wall for scratch or wear. Measure the cylinder I.D. at three levels in an X and Y axis. Take the maximum reading to determine the cylinder wear.

SERVICE LIMIT: 67.10 mm (2.642 in)

Calculate the cylinder-to-piston clearance.

SERVICE LIMIT: 0.10 mm (0.004 in)

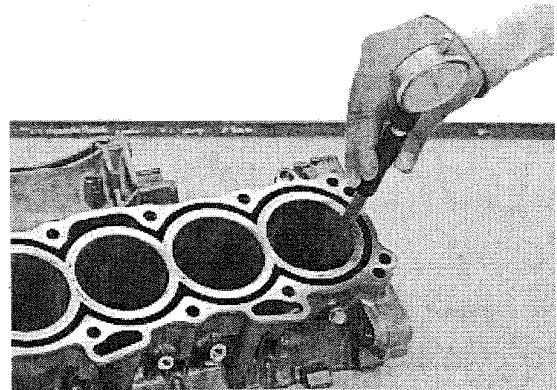

Calculate the cylinder taper and out-of-round at three levels in an X and Y axis. Take the maximum reading to determine the taper and out-of-round.

SERVICE LIMITS: Taper: 0.10 mm (0.004 in)
Out-of-round: 0.10 mm (0.004 in)

The cylinder must be rebored and an oversize piston (0.25 mm) fitted if the service limits are exceeded.

The cylinder must be rebored so that the clearance for an oversize piston is 0.015–0.050 mm (0.0006–0.0020 in).

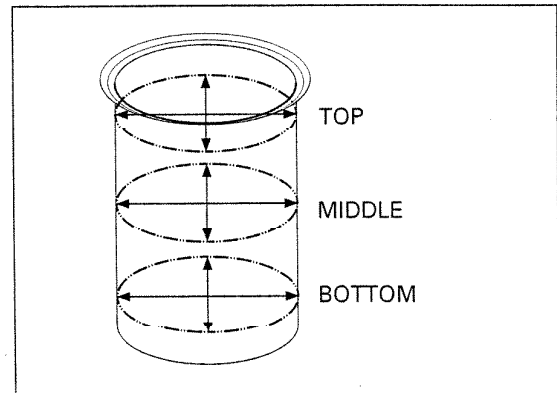

Check the top of the cylinder for warpage with a straight edge and feeler gauge.

SERVICE LIMIT: 0.10 mm (0.004 in)

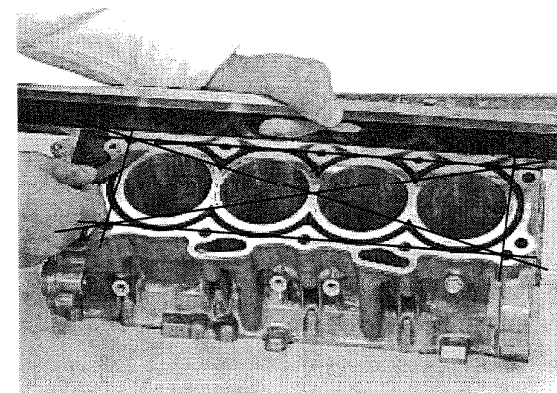

CRANKSHAFT/PISTON/CYLINDER

PISTON RING INSTALLATION

CAUTION:

Be careful not to damage the piston and rings during installation.

Carefully install the piston rings into the piston ring grooves with the markings facing up.

NOTE:

- Do not confuse the top and second rings.
- To install the oil ring, install the spacer first, then install the side rails.

Stagger the piston ring end gaps 120° apart from each other.
Stagger the side rail end gaps as shown.

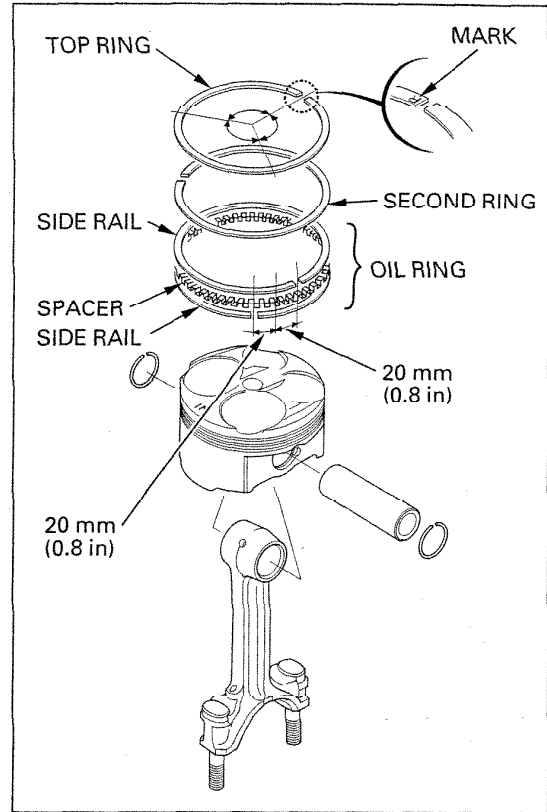
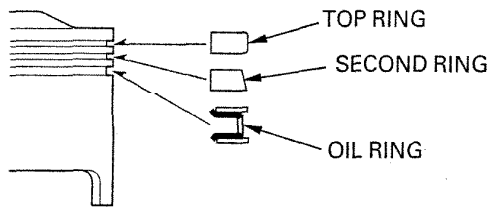

PISTON INSTALLATION

Apply molybdenum oil solution to the connecting rod small end inner surfaces and piston pin outer surfaces.

Install the piston so that the "IN" mark facing the same direction as the oil hole in the connecting rod.

Install the piston pin into the piston and connecting rod.
Install new piston pin clips into the grooves of the piston pin hole.

NOTE:

- Make sure that the piston pin clips seated securely.
- Do not align the piston pin clip end gap with the piston cut-out.

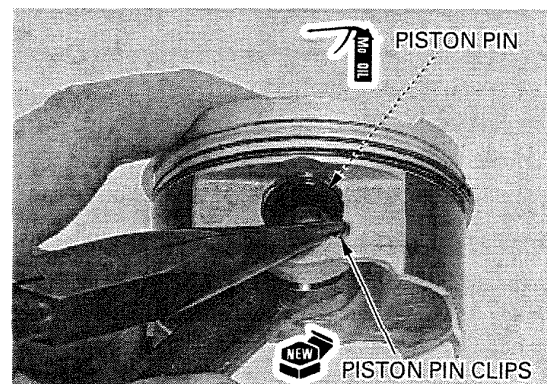
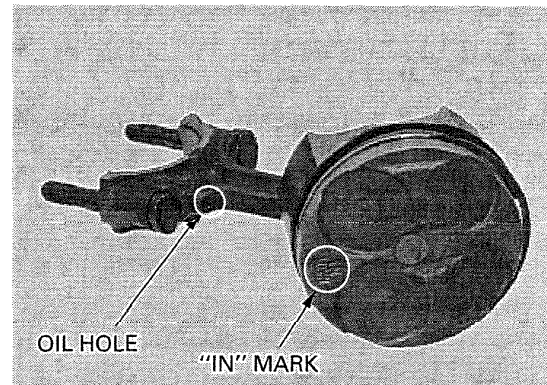

Apply engine oil to the cylinder wall, piston and piston rings.

CAUTION:

Be careful not to damage the piston rings and the cylinder wall by the connecting rod.

Install the connecting rod/piston from the top of the cylinder with the "IN" mark toward the intake side, using a commercially available piston ring compressor tool.

Install the crankshaft (page 12-5).

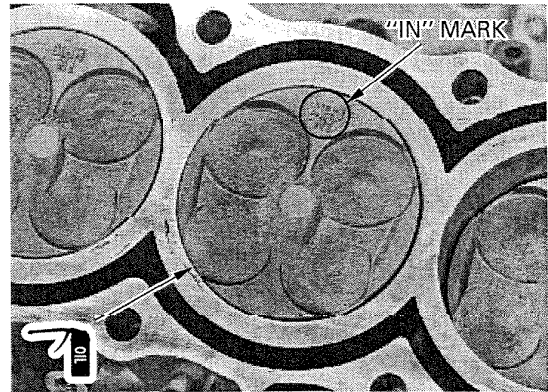

FRONT WHEEL/SUSPENSION/STEERING

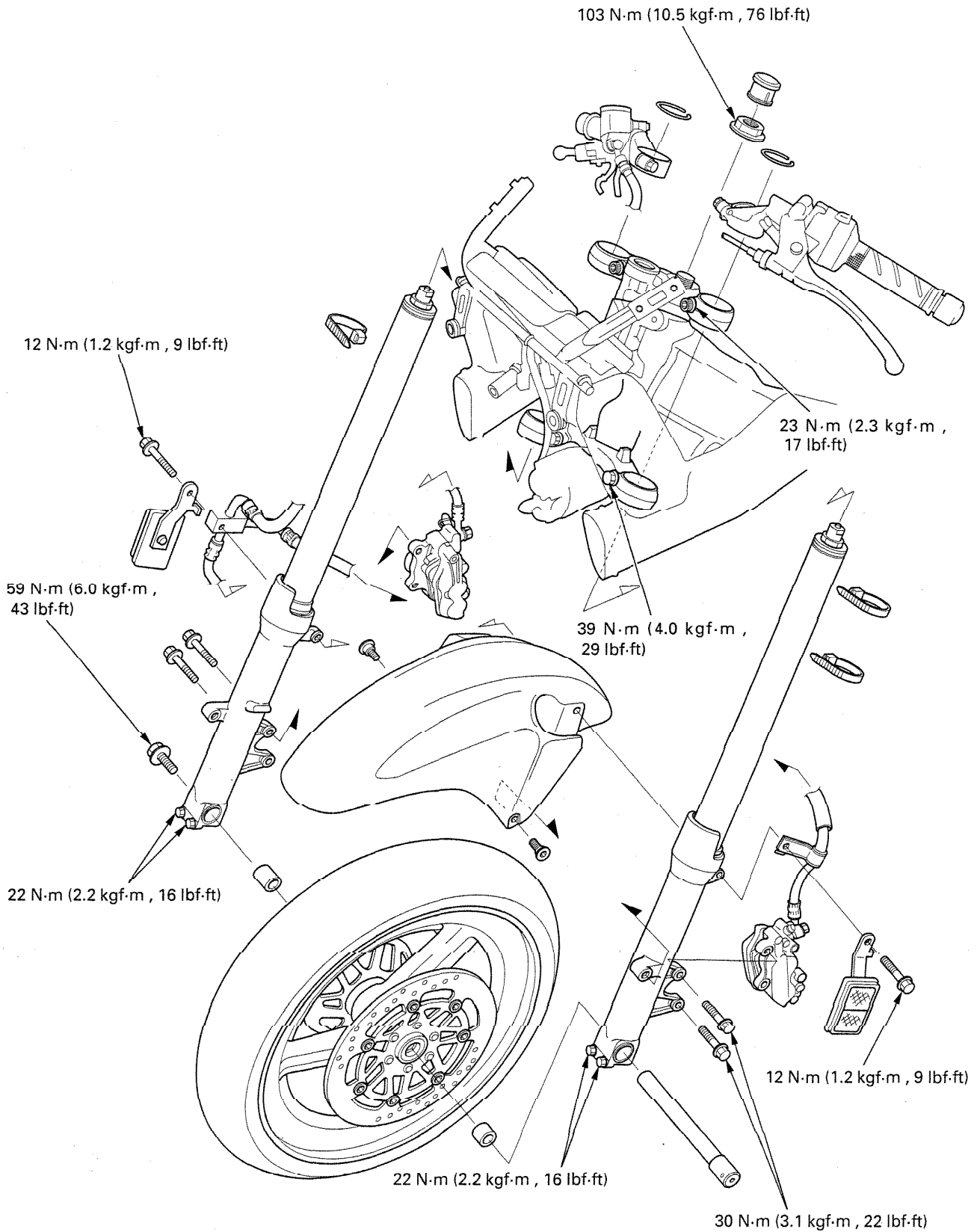

13. FRONT WHEEL/SUSPENSION/STEERING

SERVICE INFORMATION	13-1	FRONT WHEEL	13-6
TROUBLESHOOTING	13-2	FORK	13-12
HANDLEBAR	13-3	STEERING STEM	13-21

SERVICE INFORMATION

GENERAL

▲WARNING

- Riding on damaged rims impairs safe operation of the vehicle.
- A contaminated brake disc or pad reduces stopping power. Discard contaminated pads and clean a contaminated disc with a high quality brake degreasing agent.

- A hoist or equivalent is required to support the motorcycle when servicing the front wheel, fork and steering stem.
- Refer to section 15 for brake system service.

SPECIFICATIONS

Unit: mm (in)

ITEM		STANDARD	SERVICE LIMIT
Minimum tire tread depth		—————	1.5 (0.06)
Cold tire pressure	Up to 90 kg (200 lbs) load	250 kPa (2.50 kgf/cm ² , 36 psi)	—————
	Up to maximum weight capacity	250 kPa (2.50 kgf/cm ² , 36 psi)	—————
Axle runout		—————	0.2 (0.01)
Wheel rim runout	Radial	—————	2.0 (0.08)
	Axial	—————	2.0 (0.08)
Wheel balance weight		—————	60 g (2.1 oz) max.
Fork	Spring free length	336 mm (13.2 in)	329.3 (12.96)
	Tube runout	—————	0.20 (0.008)
	Recommended fluid	Pro-Honda Suspension Fluid SS-8	—————
	Fluid level	118 mm (4.6 in)	—————
	Fluid capacity	475 ± 2.5 cm ³ (16.1 ± 0.08 US oz, 16.7 ± 0.09 oz)	—————
Steering head bearing preload		1.0 – 1.5 kgf (2.2 – 3.3 lbf)	—————

13

TORQUE VALUES

Handlebar weight mounting screw	10 N·m (1.0 kgf·m, 7 lbf·ft)	ALOC screw: replace with a new one
Front brake disc bolt	20 N·m (2.0 kgf·m, 14 lbf·ft)	ALOC bolt: replace with a new one
Front axle bolt	59 N·m (6.0 kgf·m, 43 lbf·ft)	
Front axle holder bolt	22 N·m (2.2 kgf·m, 16 lbf·ft)	
Front fender bolt	12 N·m (1.2 kgf·m, 9 lbf·ft)	
Fork socket bolt	34 N·m (3.5 kgf·m, 25 lbf·ft)	
Fork cap	23 N·m (2.3 kgf·m, 17 lbf·ft)	
Fork top bridge pinch bolt	23 N·m (2.3 kgf·m, 17 lbf·ft)	
Fork bottom bridge pinch bolt	39 N·m (4.0 kgf·m, 29 lbf·ft)	
Steering bearing adjustment nut	25 N·m (2.5 kgf·m, 18 lbf·ft)	Apply oil to the threads and seating surface
Steering stem nut	103 N·m (10.5 kgf·m, 76 lbf·ft)	
Front brake hose clamp bolt (steering stem)	10 N·m (1.0 kgf·m, 7 lbf·ft)	
Front master cylinder mounting bolt	12 N·m (1.2 kgf·m, 9 lbf·ft)	
Front brake caliper mounting bolt	30 N·m (3.1 kgf·m, 22 lbf·ft)	ALOC bolt: replace with a new one

FRONT WHEEL/SUSPENSION/STEERING

TOOLS

Bearing remover shaft	07746-0050100	} or equivalent commercially available in U.S.A.
Bearing remover head, 20 mm	07746-0050600	
Driver	07749-0010000	
Attachment, 42 × 47 mm	07746-0010300	
Pilot, 20 mm	07746-0040500	
Fork seal driver weight	07947-KA50100	
Fork seal driver attachment, 43 mm I. D.	07947-KA40200	
Steering stem socket	07916-3710101 or 07916-3710100	
Ball race remover set	07946-KM90001	} not available in U.S.A.
– Driver attachment A	07946-KM90100	
– Driver attachment B	07946-KM90200	
– Driver shaft assembly	07946-KM90300	
– Bearing remover A	07946-KM90401	
– Bearing remover B	07946-KM90500	
– Assembly base	07946-KM90600	
Main bearing driver attachment	07946-ME90200	} U.S.A. only
Fork seal driver weight	07947-KA50100	
Oil seal driver	07965-MA60000	
Installer shaft	07VMF-KZ30200	
Installer attachment A	07VMF-MAT0100	
Installer attachment B	07VMF-MAT0200	
Remover attachment A	07VMF-MAT0300	
Remover attachment B	07VMF-MAT0400	
Steering stem driver	07946-MB00000	

TROUBLESHOOTING

Hard steering

- Steering bearing adjustment nut too tight
- Worn or damaged steering head bearings
- Bent steering stem
- Insufficient tire pressure

Steers one side or does not track straight

- Damaged or loose steering head bearings
- Bent forks
- Bent axle
- Wheel installed incorrectly
- Bent frame
- Worn or damaged wheel bearings
- Worn or damaged swingarm pivot bearings

Front wheel wobbling

- Bent rim
- Worn or damaged front wheel bearings
- Faulty front tire
- Unbalanced front tire and wheel

Front wheel turns hard

- Faulty front wheel bearings
- Bent front axle
- Front brake drag

Soft suspension

- Insufficient fluid in fork
- Incorrect fork fluid weight
- Weak fork springs
- Insufficient tire pressure

Hard suspension

- Bent fork tubes
- Too much fluid in fork
- Incorrect fork fluid weight
- Clogged fork fluid passage

Front suspension noise

- Insufficient fluid in fork
- Loose fork fasteners

HANDLEBAR

RIGHT HANDLEBAR REMOVAL

Hold the handlebar weight and remove the mounting screw and the weight.

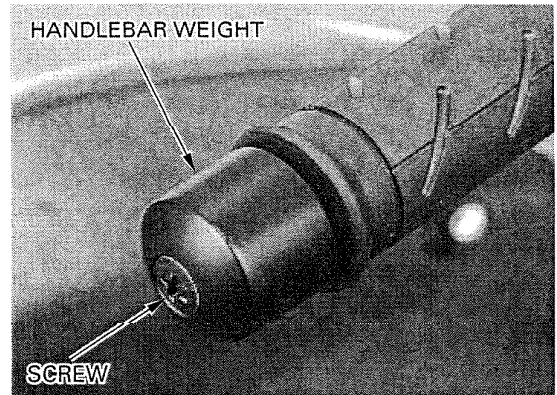

Disconnect the front brake light switch connectors.

NOTE.

Keep the brake master cylinder upright to prevent air from entering the hydraulic system.

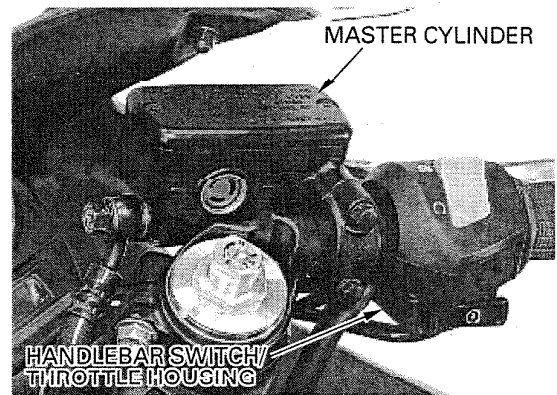

Remove the two bolts, holder and master cylinder from the handlebar.

Remove the two screws and handlebar switch/throttle housing.

Loosen the pinch bolt.
Remove the stopper ring and the handlebar from the fork.

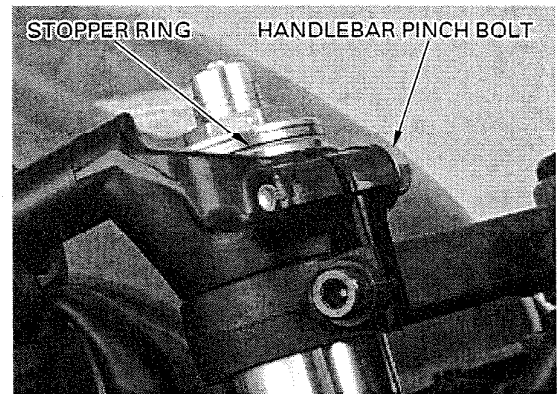

Remove the throttle grip pipe from the handlebar.

RIGHT HANDLEBAR INSTALLATION

Apply grease to the throttle grip pipe flange and install the throttle grip pipe onto the right handlebar.

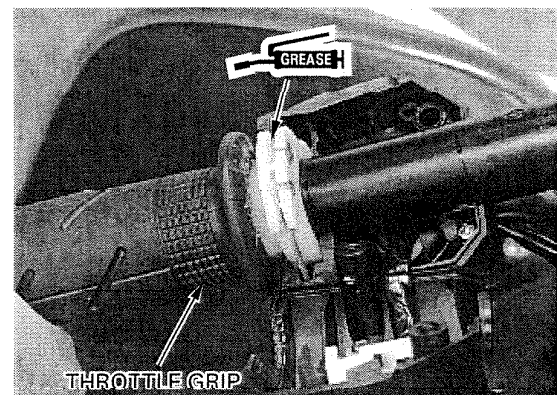

FRONT WHEEL/SUSPENSION/STEERING

Install the handlebar onto the fork, aligning its boss with the groove in the fork top bridge. Install the stopper ring and tighten the handlebar pinch bolt.

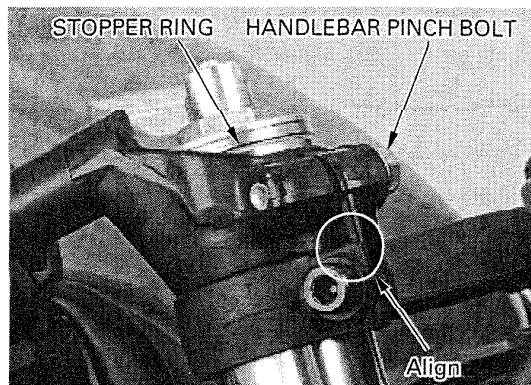

Install the right handlebar switch/throttle housing onto the handlebar, aligning its locating pin with the hole in the handlebar. Tighten the forward screw first, then the rear screw.

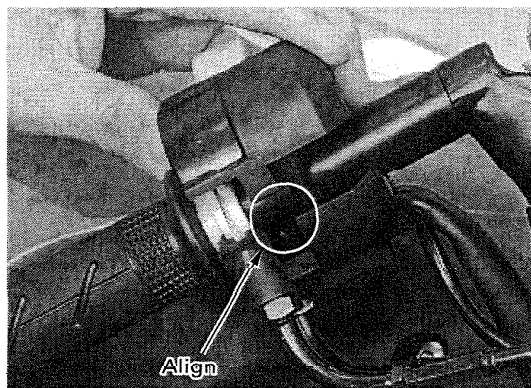

Install the front brake master cylinder and holder with the "UP" mark facing up. Align the end of the master cylinder with the punch mark on the handlebar, and tighten the upper bolt first, then the lower bolt.

TORQUE : 12 N·m (1.2 kgf·m , 9 lbf·ft)

Connect the front brake light switch connectors.

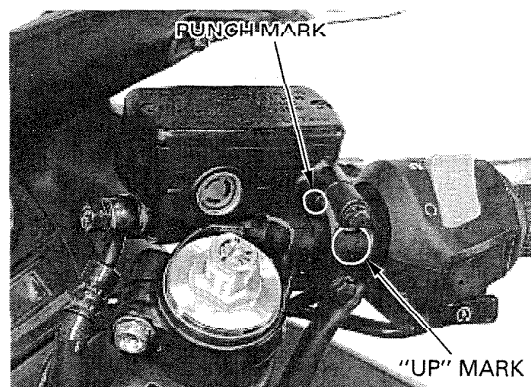

Install the handlebar weight onto the inner weight, aligning the bosses and grooves each other. Install a new weight mounting screw and tighten it while holding the weight.

TORQUE : 10 N·m (1.0 kgf·m , 7 lbf·ft)

Check the throttle grip operation and free play (page 3-4).

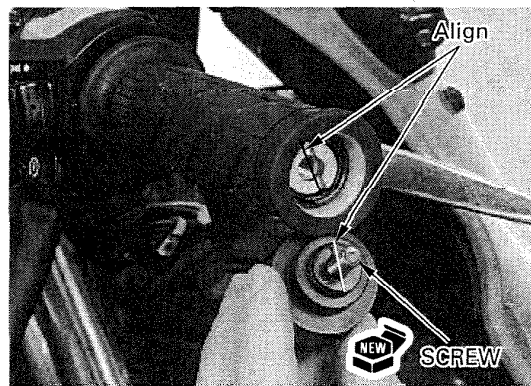

LEFT HANDLEBAR REMOVAL

Disconnect the clutch switch connectors.
Remove the two bolts, holder and clutch lever bracket from the handlebar.

Remove the two screws and left handlebar switch housing. Disconnect the choke cable from the choke lever.

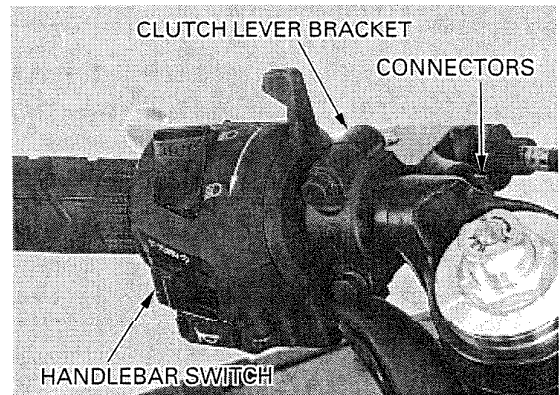

Hold the handlebar weight and remove the mounting screw and weight.

Remove the left handlebar grip and choke lever from the handlebar.



Loosen the pinch bolt.
Remove the stopper ring and the handlebar from the fork.

LEFT HANDLEBAR INSTALLATION

Install the handlebar onto the fork, aligning its boss with the groove in the fork top bridge.
Install the stopper ring and tighten the handlebar pinch bolt.

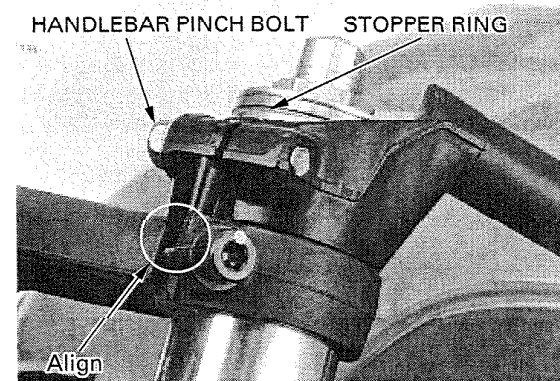

Clean the inside surface of the left handlebar grip and the outside surface of the left handlebar.
Apply Honda Bond A or equivalent to the inside surface of the left handlebar grip and to the outside surface of the left handlebar. Wait 3–5 minutes and install the choke lever and the grip.

Rotate the grip for even application of the adhesive.

NOTE:

Allow the adhesive to dry for an hour before using.



FRONT WHEEL/SUSPENSION/STEERING

Install the handlebar weight onto the inner weight, aligning the bosses and grooves each other. Install a new weight mounting screw and tighten it while holding the weight.

TORQUE : 10 N·m (1.0 kgf·m , 7 lbf·ft)

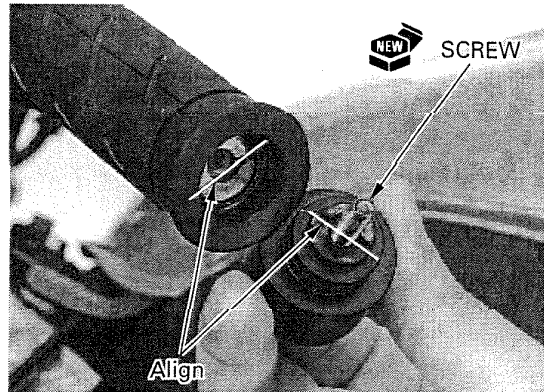

Connect the choke cable to the choke lever.

Install the left handlebar switch housing onto the handlebar, aligning its locating pin with the hole in the handlebar.

Tighten the forward screw first, then the rear screw.

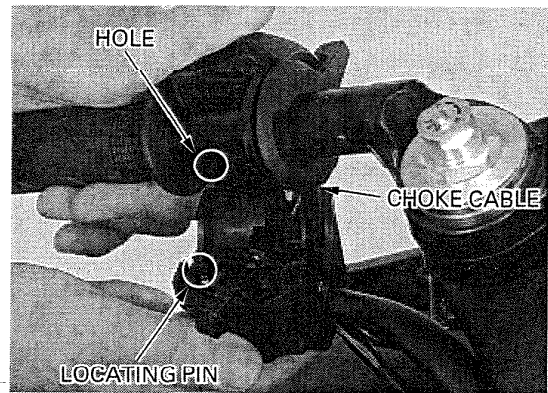

Install the clutch lever bracket and bracket holder with the "UP" mark facing up.

Align the end of the clutch lever bracket with the punch mark on the handlebar, and tighten the upper bolt first, then the lower bolt.

Connect the clutch switch connectors.

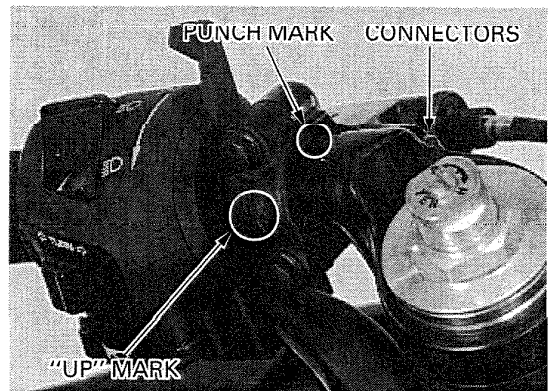

FRONT WHEEL

REMOVAL

Support the motorcycle securely using a hoist or equivalent and raise the front wheel off the ground.

Remove the four bolts and the front fender. Remove the mounting bolts and front brake calipers.

CAUTION:

Support the brake caliper so that it does not hang from the brake hose. Do not twist the brake hose.

NOTE:

Do not operate the brake lever after removing the brake calipers.

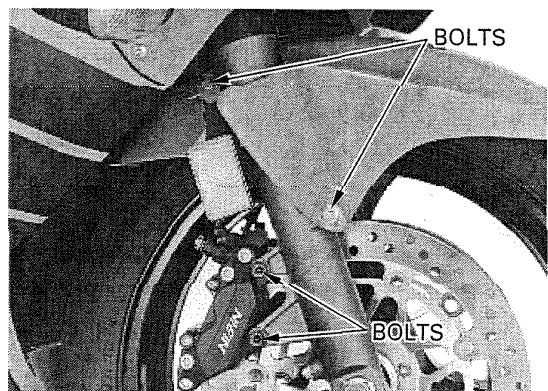

FRONT WHEEL/SUSPENSION/STEERING

Loosen the right front axle holder bolts.
Remove the front axle bolt.

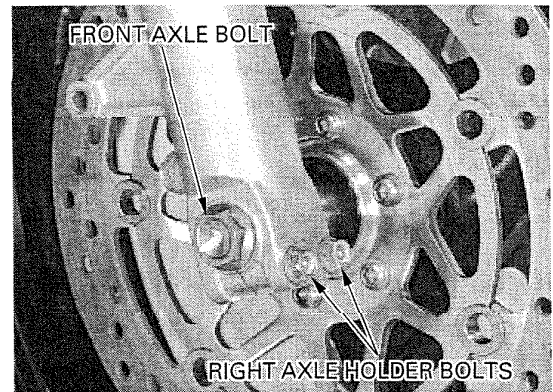

Loosen the left front axle holder bolts.
Remove the front axle and the front wheel.

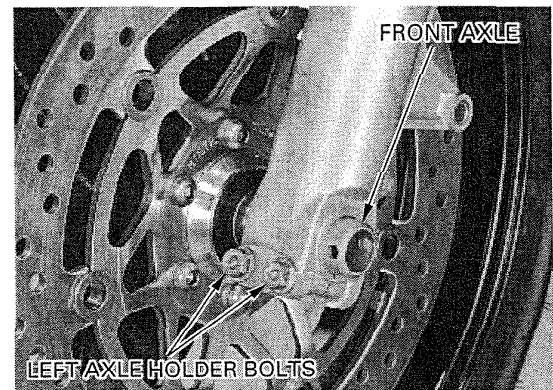

Remove the side collars.

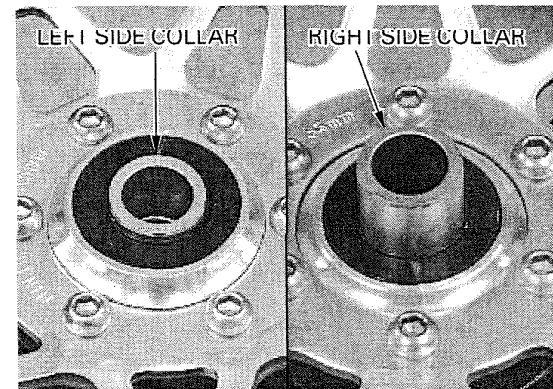

INSPECTION

AXLE

Set the front axle in V-blocks.
Turn the front axle and measure the runout using a dial indicator.
Actual runout is 1/2 the total indicator reading.

SERVICE LIMIT: 0.2 mm (0.01 in)

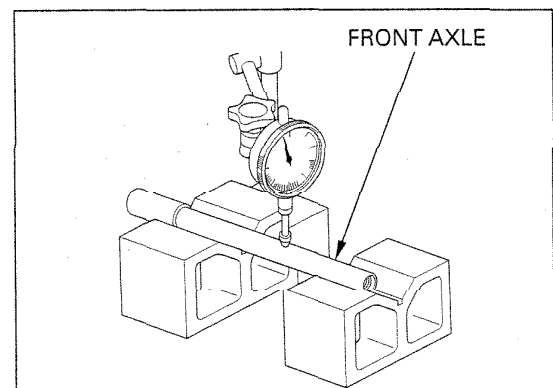

FRONT WHEEL/SUSPENSION/STEERING

WHEEL RIM

Check the rim runout by placing the wheel in a truing stand.
Spin the wheel slowly and read the runout using a dial indicator.
Actual runout is 1/2 the total indicator reading.

SERVICE LIMITS: Radial: 2.0 mm (0.08 in)
Axial: 2.0 mm (0.08 in)

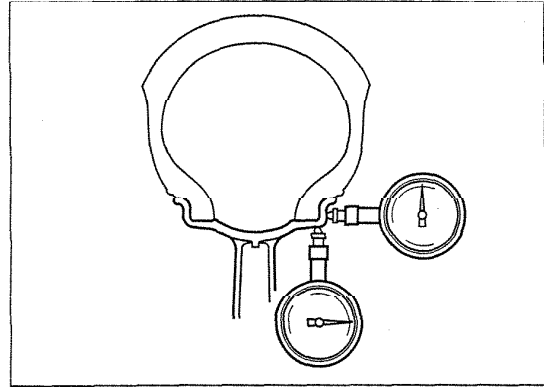

WHEEL BEARING

Turn the inner race of each bearing with your finger. The bearings should turn smoothly and quietly. Also check that the bearing outer race fits tightly in the hub.

Replace the wheel bearings in pairs.

Remove and discard the bearings if the races do not turn smoothly and quietly, if they fit loosely in the hub.

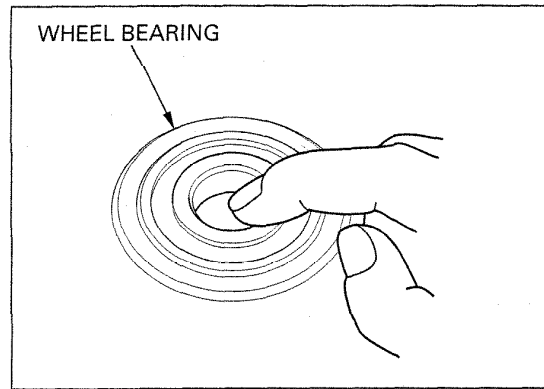

DISASSEMBLY

Remove the dust seals from the wheel hub.
Remove the disc bolts and brake discs from the wheel hub.

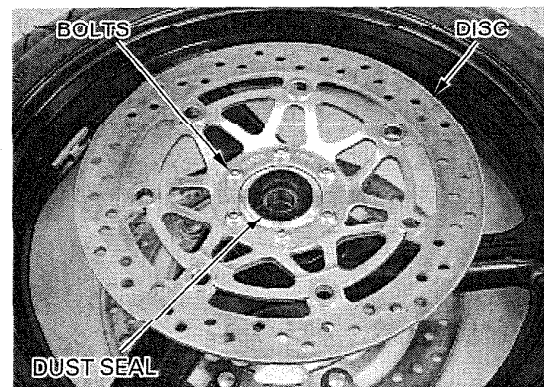

Replace the wheel bearings in pairs. Do not reuse old bearings.

Install the bearing remover head into the bearing. From opposite side, install the bearing remover shaft and drive the bearing out of the wheel hub.

Remove the distance collar and drive out the other bearing.

TOOLS:

Bearing remover shaft 07746-0050100 or equivalent commercially available in U.S.A.

Bearing remover head, 20 mm 07746-0050600 or equivalent commercially available in U.S.A.

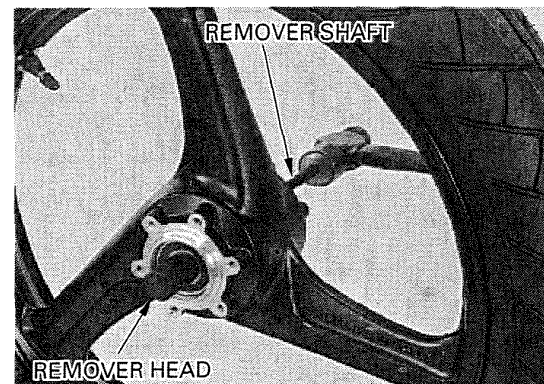

ASSEMBLY

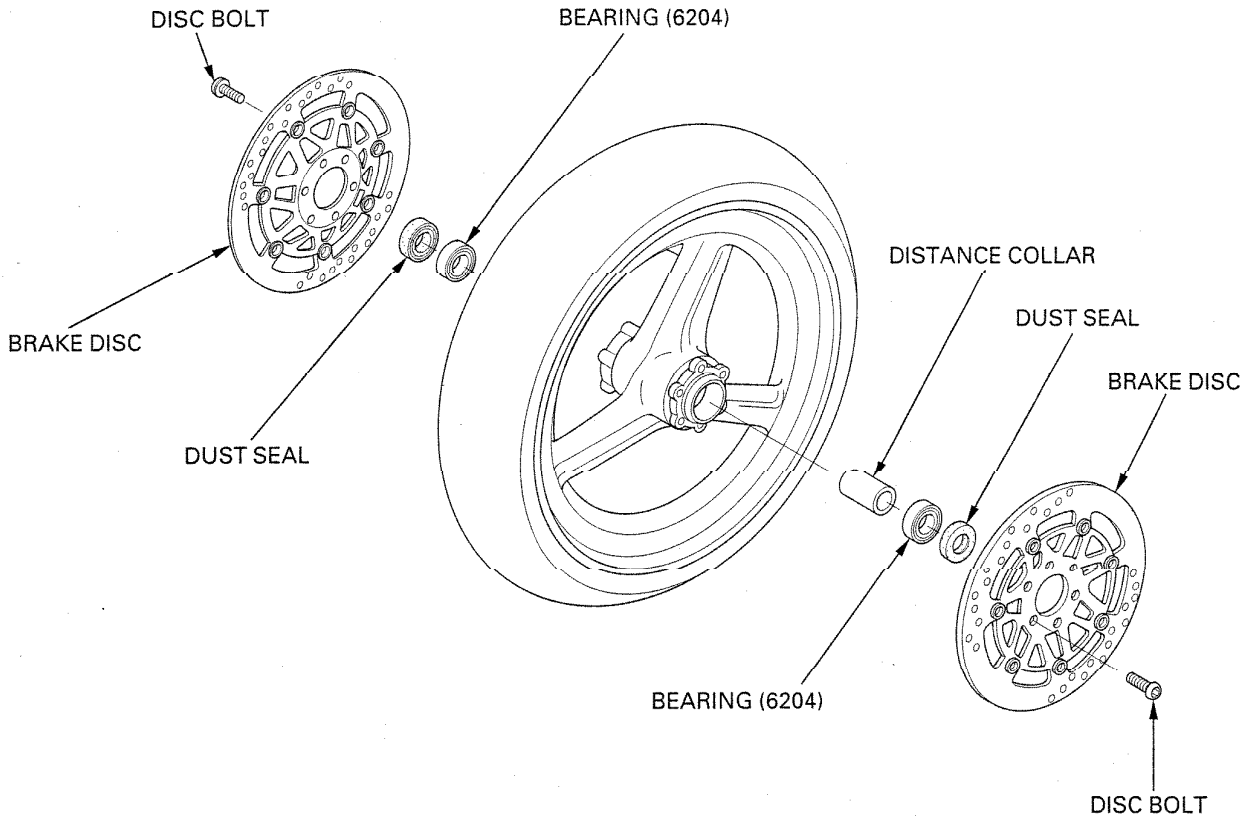

Drive in a new right bearing squarely with the marking side facing up until it is fully seated.
Install the distance collar.
Drive in a new left bearing squarely with the marking side facing up until it is fully seated.

TOOLS:

Driver	07749-0010000
Attachment, 42 × 47 mm	07746-0010300
Pilot, 20 mm	07746-0040500

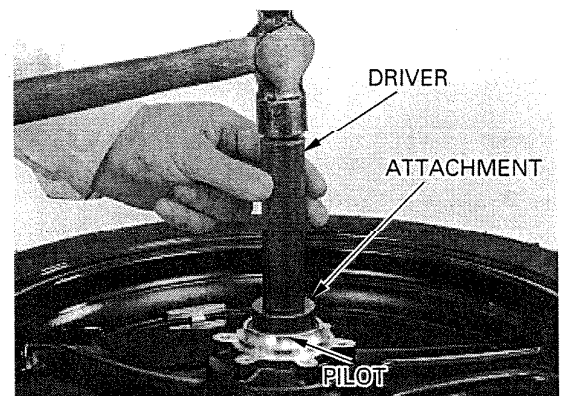

▲WARNING

Do not get grease on the brake disc or stopping power will be reduced.

Install the brake discs with the arrow mark facing in the normal rotating direction.
Install new disc bolts and tighten them in a criss-cross pattern in 2 or 3 steps.

TORQUE : 20 N·m (2.0 kgf·m , 14 lbf·ft)

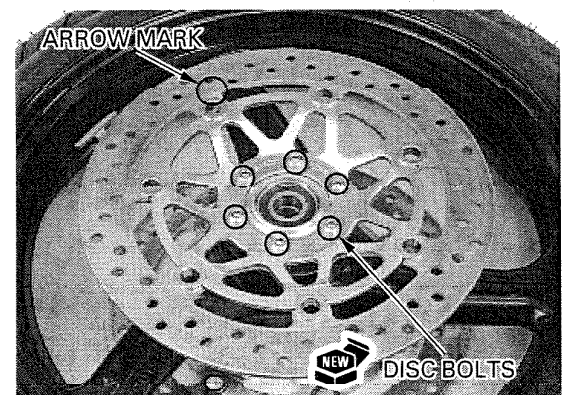

FRONT WHEEL/SUSPENSION/STEERING

Apply grease to new dust seal lips.
Install the dust seals into the wheel hub.



WHEEL BALANCE

▲WARNING

Wheel balance directly affects the stability, handling and overall safety of the motorcycle. Carefully check balance before reinstalling the wheel.

NOTE:

- Mount the tire with the arrow mark facing in the normal rotating direction.
- The wheel balance must be checked when the tire is remounted.
- For optimum balance, the tire balance mark (a paint dot on the side wall) must be located next to the valve stem. Remount the tire if necessary.

Mount the wheel, tire and brake disc assembly on an inspection stand.

Spin the wheel, allow it to stop, and mark the lowest (heaviest) part of the wheel with chalk.

Do this two or three times to verify the heaviest area.

If wheel is balanced, it will not stop consistently in the same position.

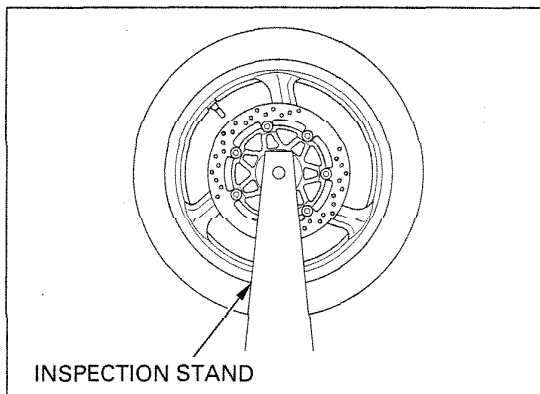
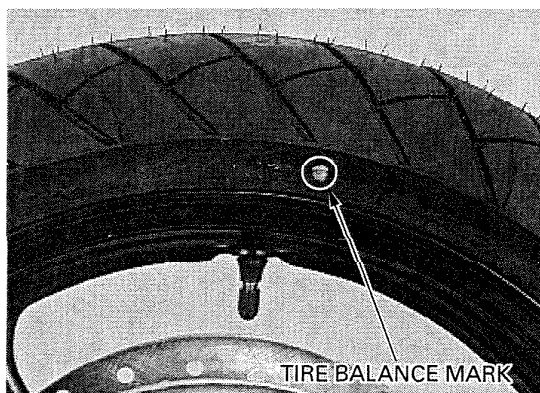

To balance the wheel, install balance weights on the lightest side of rim, the side opposite the chalk marks.

Add just enough weight so the wheel will no longer stop in the same position when it is spun.

Do not add more than 60 g (2.1 oz) to the wheel.



INSTALLATION

Install the side collars.

NOTE:

The right side collar is longer than the left side collar.

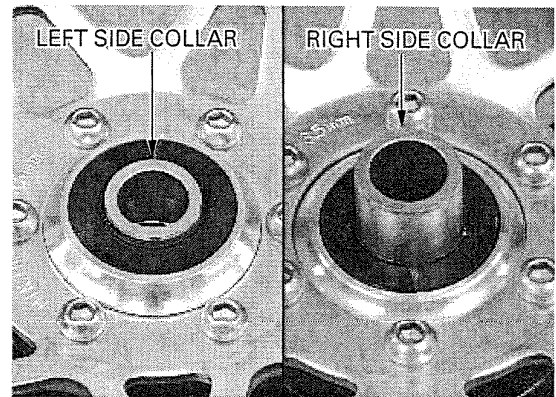

Install the front wheel between the fork legs.

Apply thin coat of grease to the front axle.
Install the front axle from the left side.

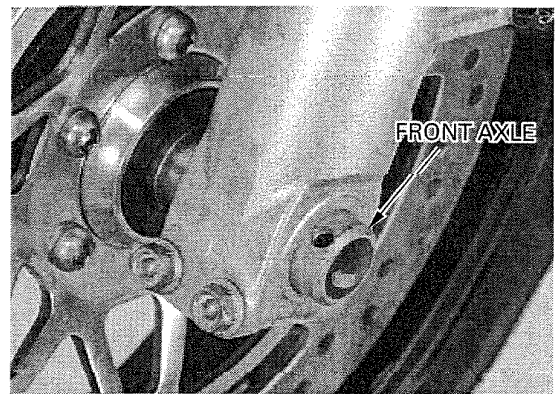

Install the front axle bolt and tighten it while holding the axle.

TORQUE : 59 N·m (6.0 kgf·m , 43 lbf·ft)

Tighten the right axle holder bolts.

TORQUE : 22 N·m (2.2 kgf·m , 16 lbf·ft)

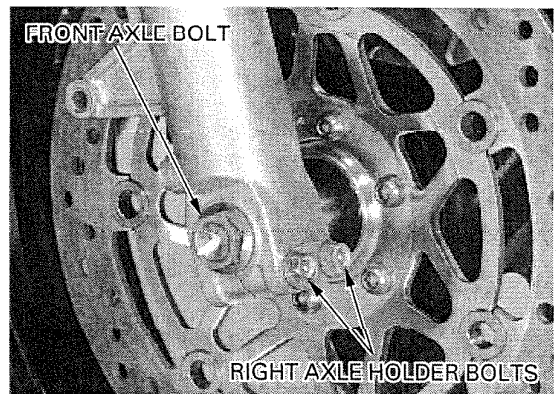

Install the brake calipers with new mounting bolts and tighten the bolts.

TORQUE : 30 N·m (3.1 kgf·m , 22 lbf·ft)

Install the front fender.

Install the four fender bolts with the brake hose clamp, 3-way joint and reflectors and tighten them.

TORQUE : 12 N·m (1.2 kgf·m , 9 lbf·ft)

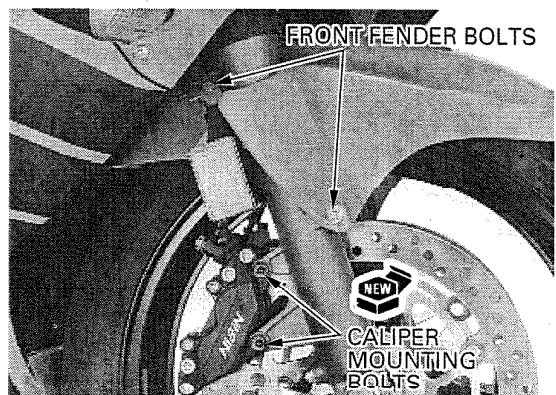

FRONT WHEEL/SUSPENSION/STEERING

With the front brake applied, pump the forks up and down several times to seat the axle and check brake operation.

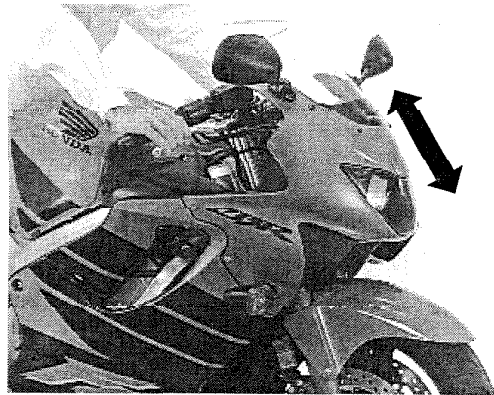

Tighten the left axle holder bolts.

TORQUE : 22 N·m (2.2 kgf·m , 16 lbf·ft)

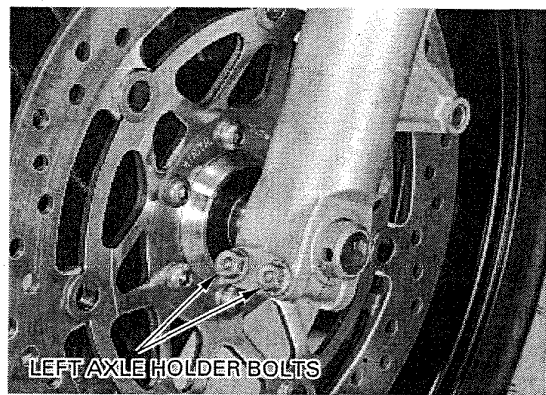

FORK

REMOVAL

Remove the front wheel (page 13-6).
Remove the wire band(s).

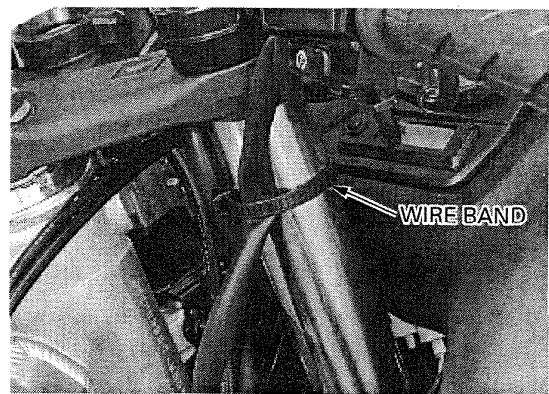

Loosen the handlebar pinch bolt and remove the stopper ring from the fork.

When the fork is ready to be disassembled, loosen the fork cap, but do not remove it yet.

Remove the handlebar assembly and secure it.

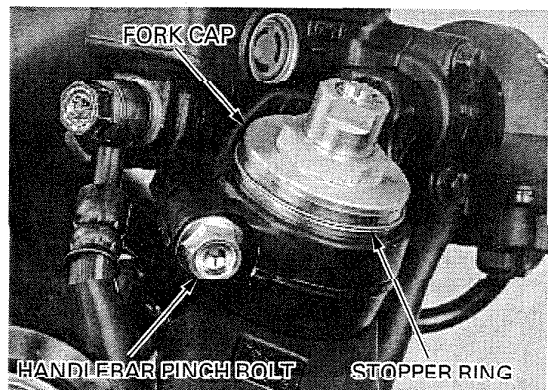

Loosen the fork top and bottom pinch bolts and remove the fork tube from the fork bridges.

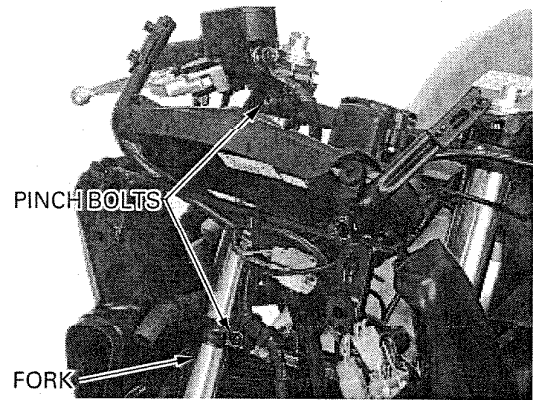

DISASSEMBLY

Remove the fork cap from the fork tube.

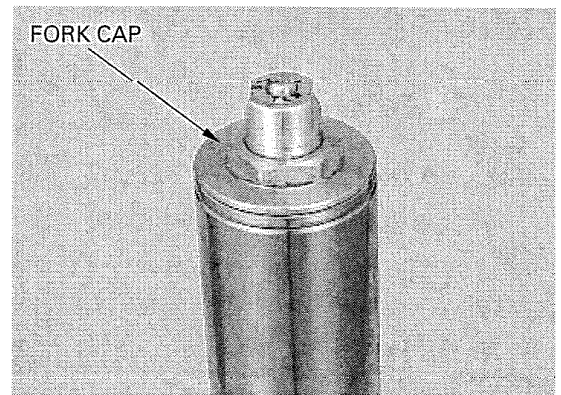

Hold the rebound damping adjuster and remove the fork cap from the damping adjuster. Remove the O-ring.

CAUTION:

Do not remove the rebound damping adjuster from the damper rod, or fork damping force will change.

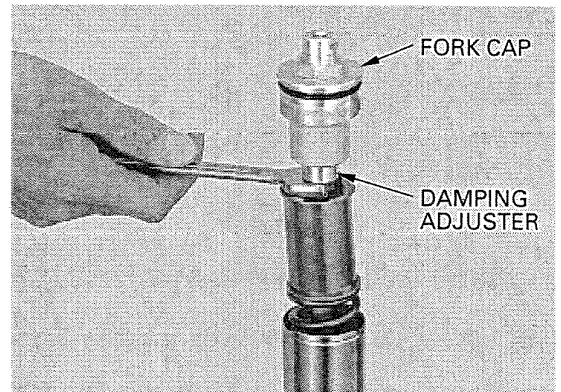

Remove the joint plate, joint collar and spring seat. Remove the O-ring.

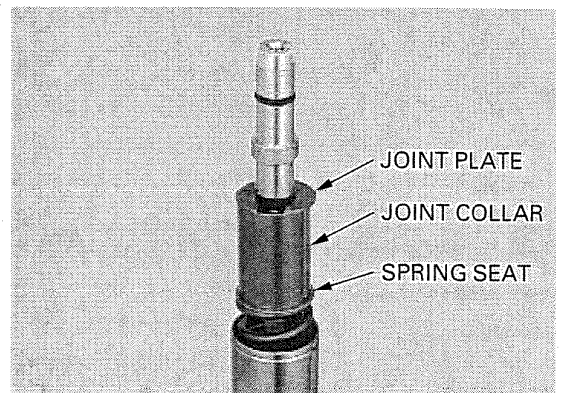

FRONT WHEEL/SUSPENSION/STEERING

Remove the fork spring.
Pour out the fork fluid by pumping the fork tube
and the damper rod several times.

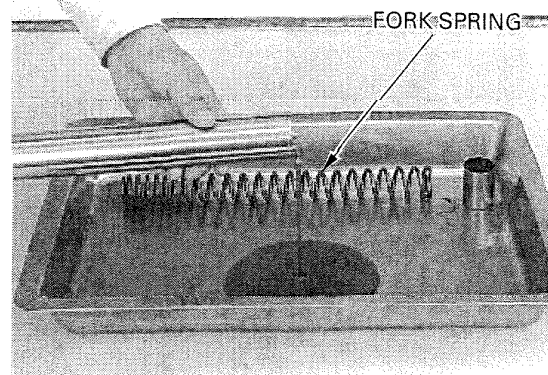

Hold the fork slider in a vise with a soft jaws or
shop towel and remove the socket bolt.

NOTE:

If the fork damper turns together with the socket
bolt, temporarily install the fork spring, spring seat,
joint collar and fork cap.

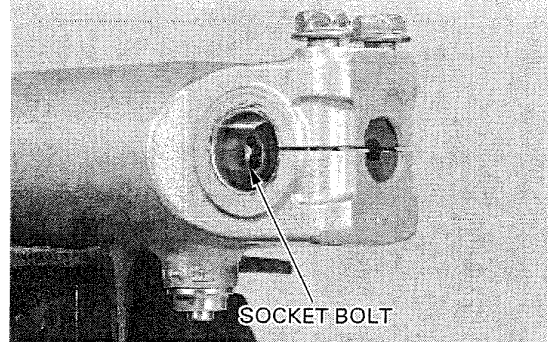

Remove the fork damper from the fork tube.

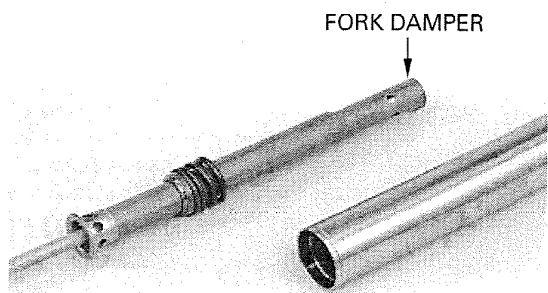

Remove the dust seal and the fork protector.

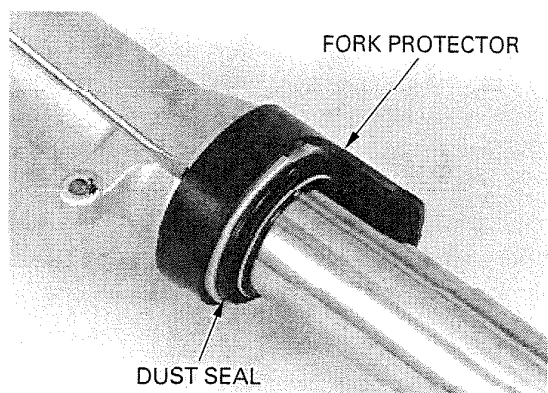

FRONT WHEEL/SUSPENSION/STEERING

Remove the stopper ring being careful not to scratch the fork tube sliding surface.

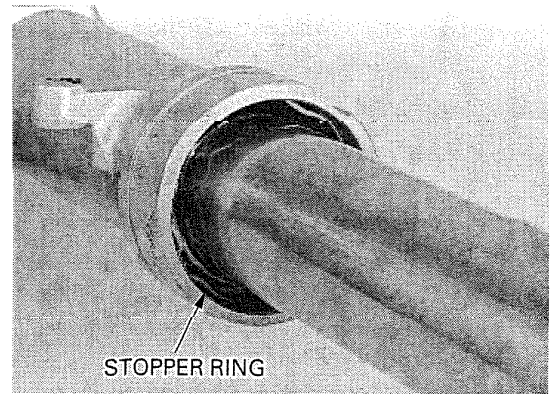

Using quick successive motions, pull the fork tube out of the fork slider.

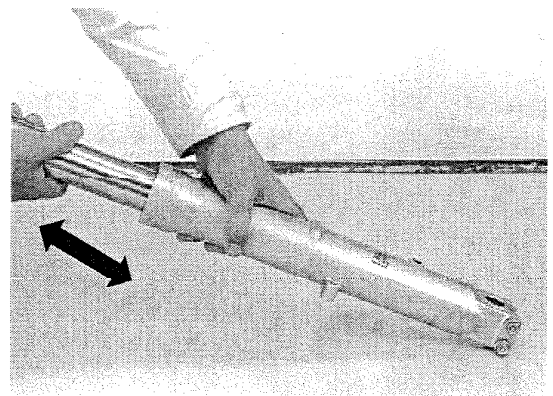

Remove the oil seal, back-up ring and guide bushing from the fork tube.

NOTE:

Do not remove slider bushing unless it is necessary to replace it with a new one.

Carefully remove the slider bushing by prying the slit with a screwdriver until the bushing can be pulled off by hand.

Remove the oil lock piece from the fork slider.
Remove the O-ring.

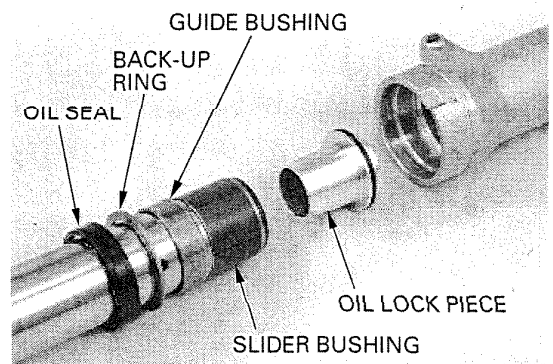

FRONT WHEEL/SUSPENSION/STEERING

INSPECTION

Measure the fork spring free length.

SERVICE LIMIT: 329.3 mm (12.96 in)

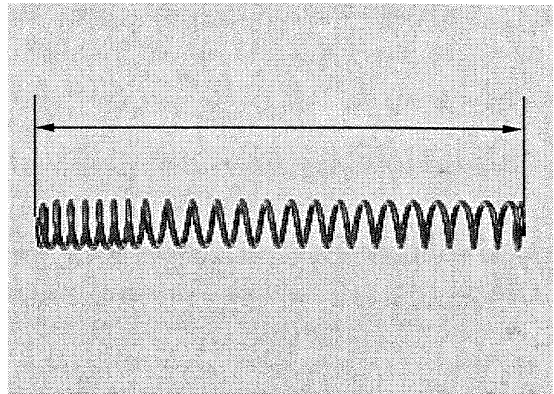

Check the fork tube, slider and damper piston for score marks, and excessive or abnormal wear. Check the rebound spring for fatigue or damage.

Replace the component if necessary.

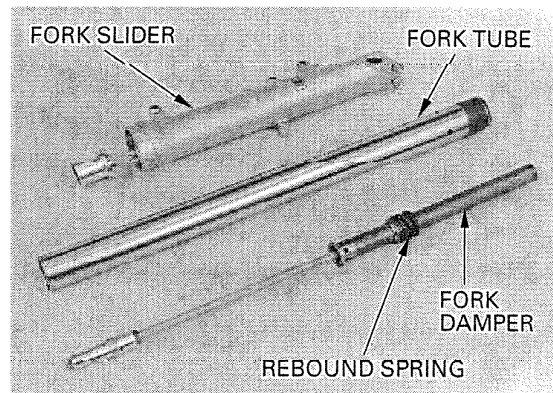

Set the fork tube in V blocks and measure the fork tube runout with a dial indicator. Actual runout is 1/2 the total indicator reading.

SERVICE LIMIT: 0.20 mm (0.008 in)

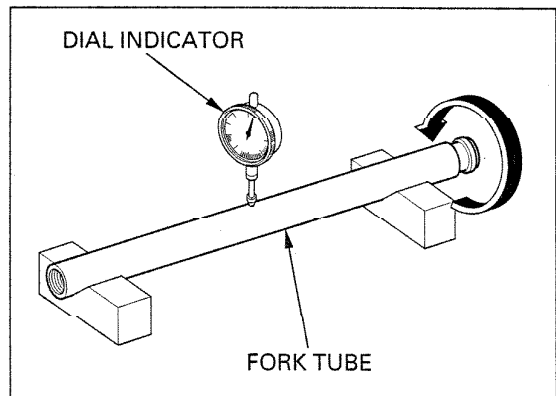

Visually inspect the slider and guide bushings. Replace the bushings if there is excessive scoring or scratching, or if the teflon is worn so that the copper surface appears on more 3/4 of the entire surface.

Check the back-up ring; replace it if there is any distortion at the points shown.

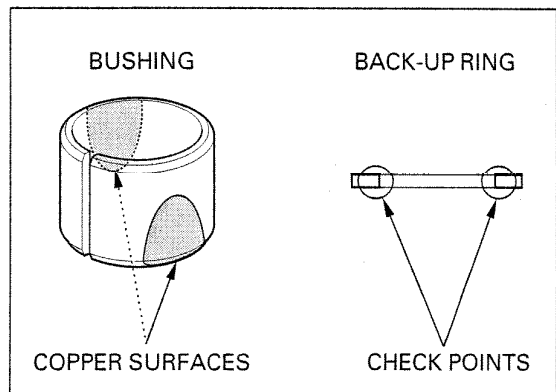

ASSEMBLY

Before assembly, wash all parts with a high flash point or non-flammable solvent and wipe them off completely.

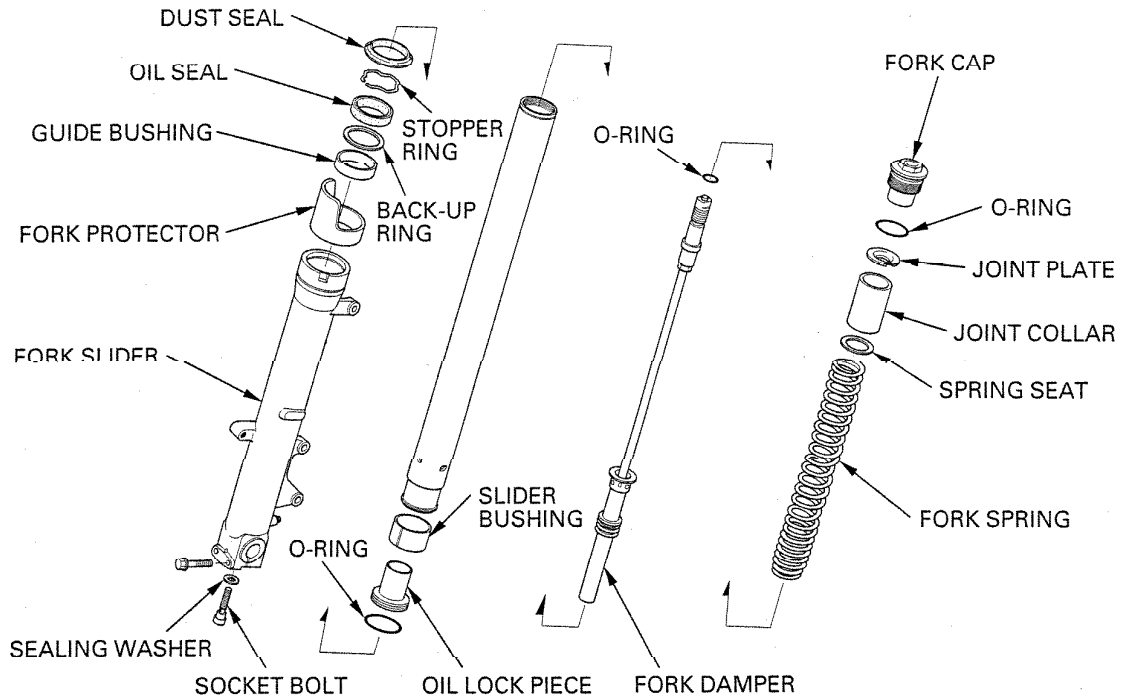

Install a new slider bushing if it has been removed.

CAUTION:

- *Be careful not to damage the coating of the bushing.*
- *Do not open the bushing more than necessary.*

NOTE:

Remove the burrs from the bushing mating surface, being careful not to peel off the coating.

Coat new O-ring with fork fluid and install it into the groove in the oil lock piece.

Install the oil lock piece into the fork tube.

Install the fork tube into the fork slider.

Install the fork damper into the fork tube.

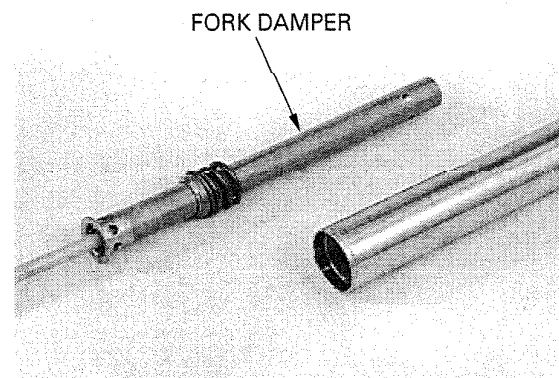
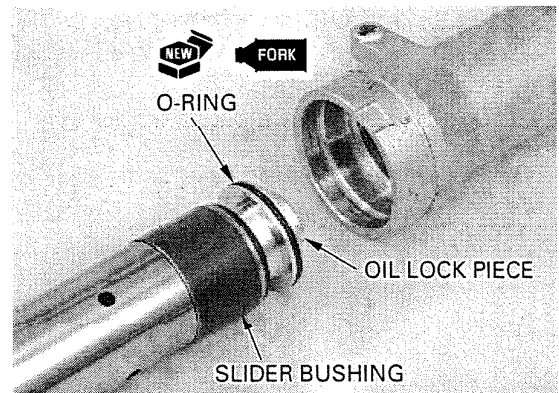

FRONT WHEEL/SUSPENSION/STEERING

Hold the fork slider in a vise with a soft jaws or shop towel.

Install the socket bolt with a new sealing washer and tighten it.

TORQUE : 34 N·m (3.5 kgf·m , 25 lbf·ft)

NOTE:

If the fork damper turns together with the socket bolt, temporarily install the fork spring, spring seat, joint collar and fork cap.

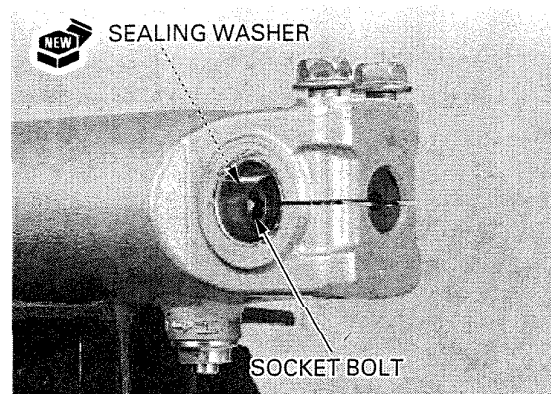

Place the guide bushing over the fork tube and rest it on the slider. Put the back-up ring and an old bushing or equivalent tool on top of the guide bushing.

Drive the bushing into place and remove the old bushing or equivalent tool.

Wrap vinyl tape around the fork tube top end to avoid damaging the oil seal lip.

Coat a new oil seal with fork fluid and install it over the fork tube with the marked side facing up.

Drive the oil seal until the stopper ring groove is visible.

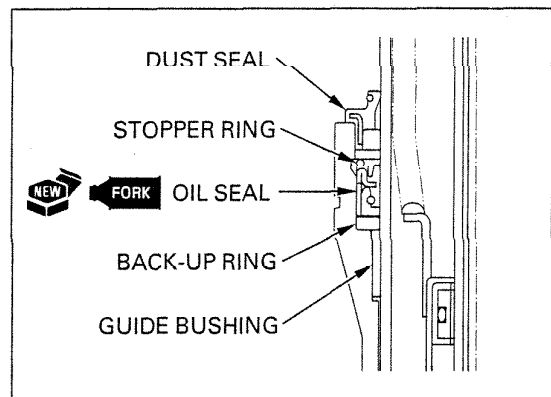

TOOLS:

Fork seal driver weight 07947-KA60100

Fork seal driver attachment, 43 mm I. D. 07947-KA40200

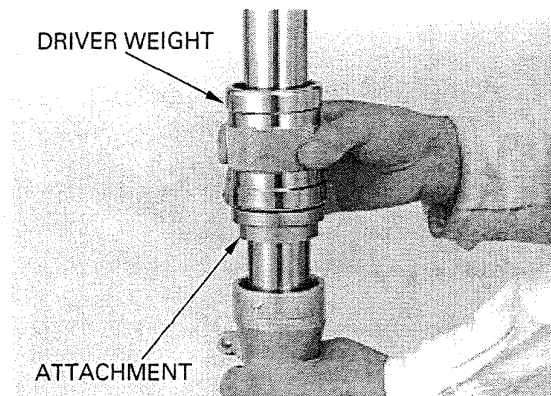

Install the stopper ring into the groove in the fork slider.

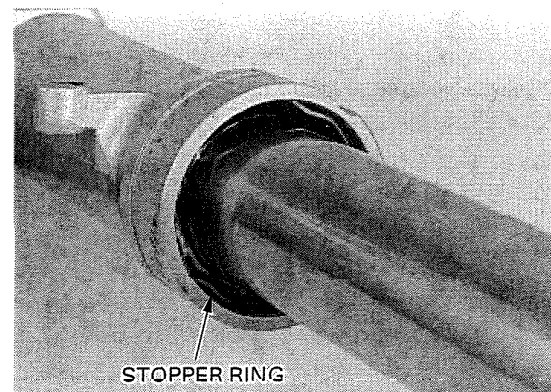

Apply fork fluid to a new dust seal lip and install the dust seal into the fork slider.
Install the fork protector over the fork slider by aligning the tab with the slider groove.

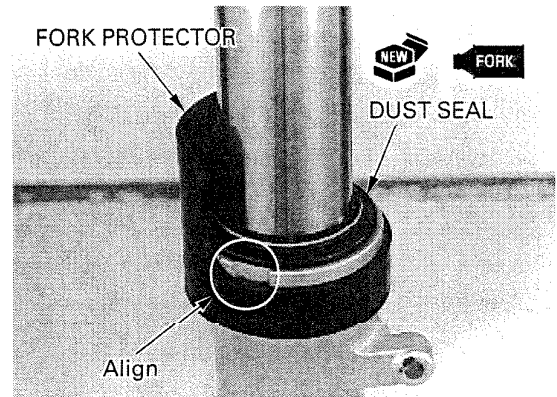

Pour the specified amount of recommended fork fluid in the fork tube.

RECOMMENDED FORK FLUID:
Pro-Honda Suspension Fluid SS-8

FORK FLUID CAPACITY:
 $475 \pm 2.5 \text{ cm}^3$ ($16.1 \pm 0.08 \text{ US oz}$, $16.7 \pm 0.09 \text{ oz}$)

Pump the damper rod several times until the fork fluid flows out of the oil hole in the rebound damping adjuster.

Slowly pump the fork tube several times to remove trapped air.

Compress the fork tube fully.

Measure the oil level from the top of the fork tube.

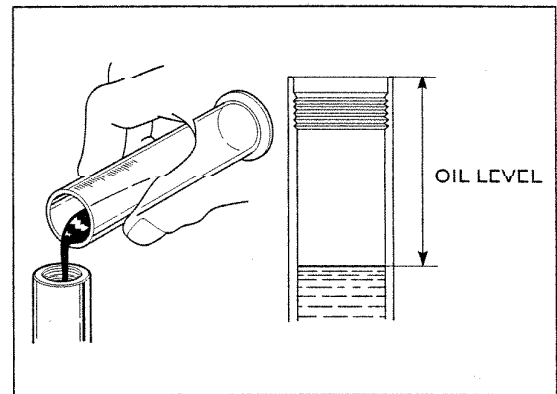

OIL LEVEL: 118 mm (4.6 in)

Pull up the damper rod fully.

Install the fork spring with the tightly wound end facing down.

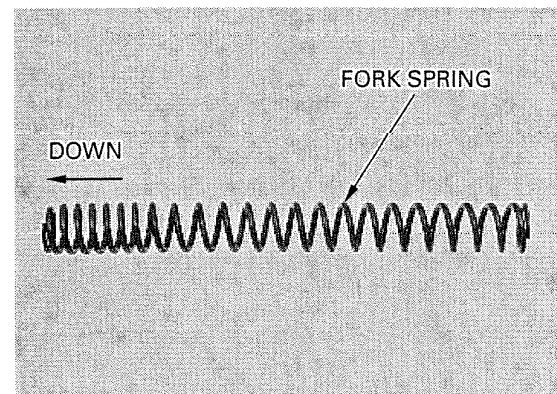

Coat new O-ring with fork fluid and install it into the groove in the rebound damping adjuster.
Install the spring seat, joint collar and joint plate.

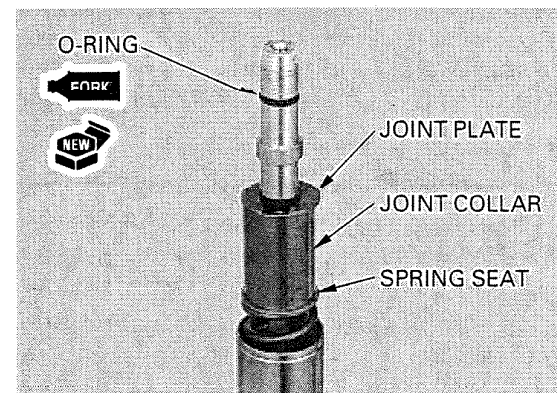

FRONT WHEEL/SUSPENSION/STEERING

Coat new O-ring with fork fluid and install it into the groove in the fork cap.
Install the fork cap onto the rebound damping adjuster.

Hold the rebound damping adjuster and screw in the fork cap.

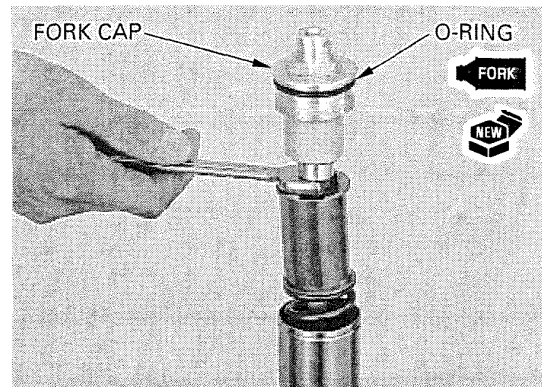

Install the fork cap into the fork tube.

NOTE:

Tighten the fork cap after installing the fork tube into the fork bridges.

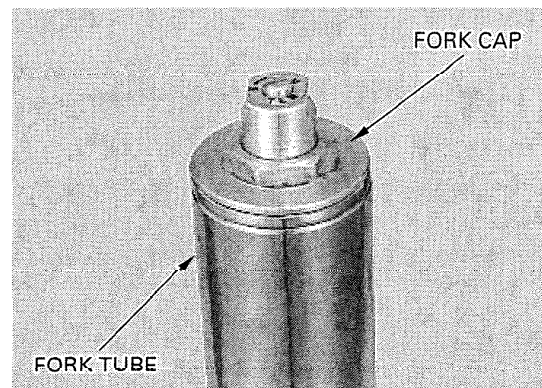

INSTALLATION

Route the cables, wire harnesses and hoses properly (page 1-18).

Install the fork tube into the fork bridges so that the height from the top bridge upper surface to the fork tube end is 33 mm (1.3 in).
Tighten the fork top bridge pinch bolt.

TORQUE : 23 N·m (2.3 kgf·m , 17 lbf·ft)

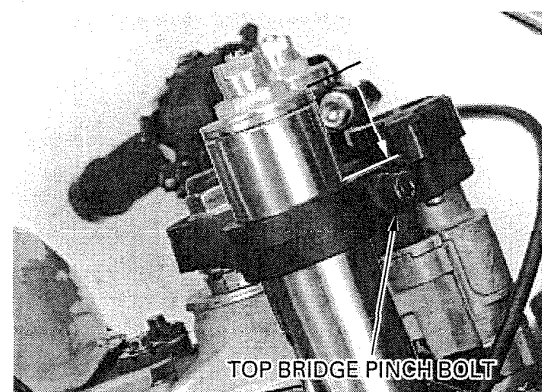

Tighten the fork bottom bridge pinch bolt.

TORQUE : 39 N·m (4.0 kgf·m , 29 lbf·ft)

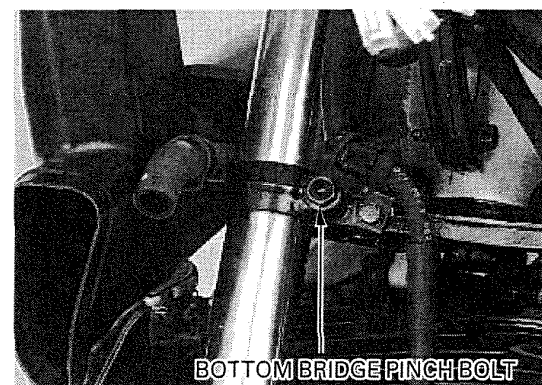

FRONT WHEEL/SUSPENSION/STEERING

Tighten the fork cap to the specified torque if it was removed.

TORQUE : 23 N·m (2.3 kgf·m , 17 lbf·ft)

Install the handlebar.
Install the stopper ring.
Make sure that the handlebar boss is positioned in the fork top bridge groove.
Tighten the handlebar pinch bolt.

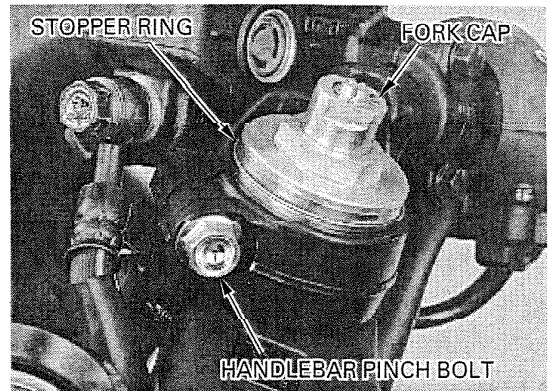

Right fork: Secure the handlebar switch wire with the wire band.

Left fork: Secure the handlebar switch and horn wires with the wire bands (page 1-18).

Install the front wheel (page 13-11).

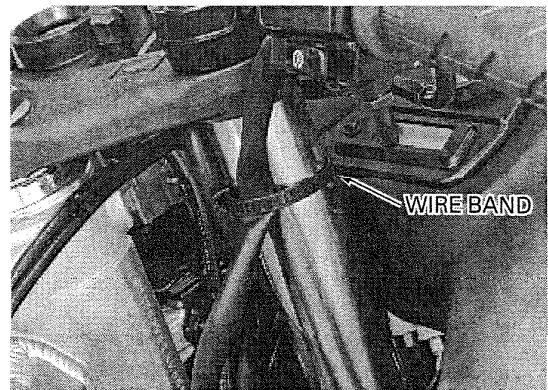

STEERING STEM

REMOVAL

Remove the front wheel (page 13-6).
Remove the left air intake duct (page 2-6).

Release the wire band and disconnect the ignition switch 4P (White) connector.

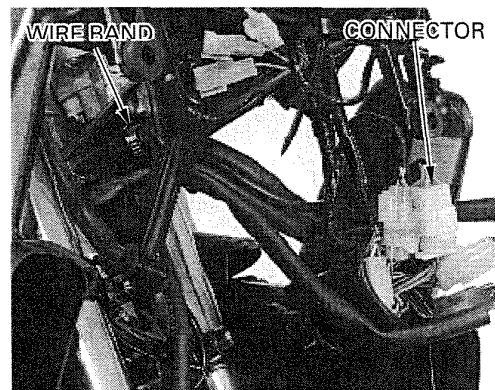

Remove the bolt and front brake hose clamp.

Disconnect the horn connectors.
Remove the bolt and horn.

Remove the forks (page 13-12).

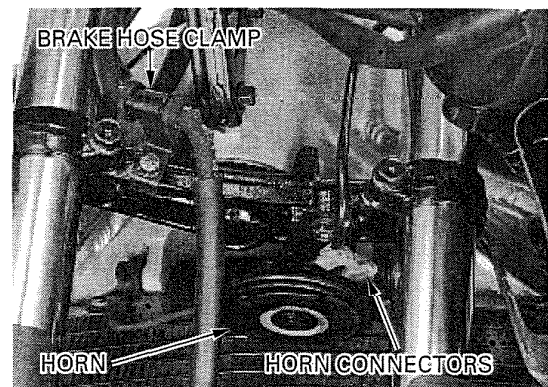

FRONT WHEEL/SUSPENSION/STEERING

Remove the steering stem nut cap.

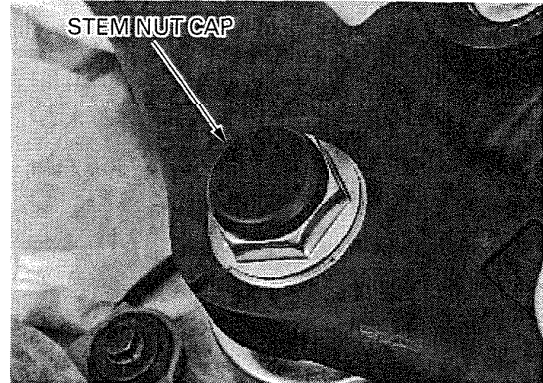

Temporarily install the forks into the fork bridges.

Loosen the steering stem nut.
Remove the forks, stem nut and fork top bridge.

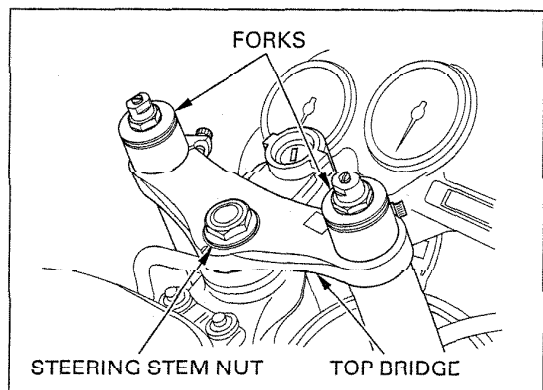

Straighten the lock washer tabs.
Remove the steering bearing adjustment nut lock nut and lock washer.

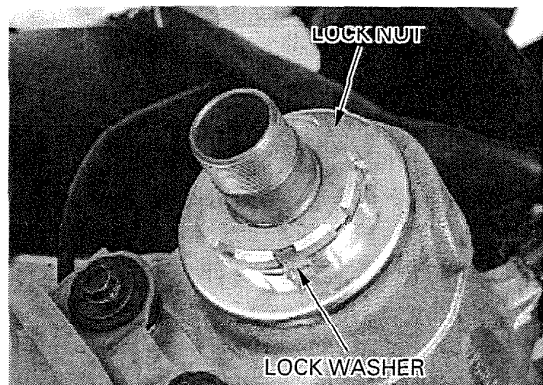

Remove the steering bearing adjustment nut using the special tool.

TOOL:
Steering stem socket

07916-3710101 or
07916-3710100

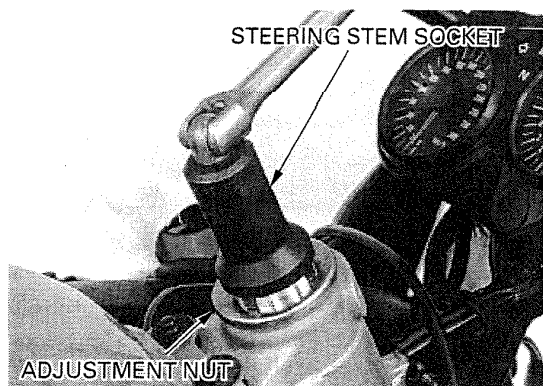

Remove the dust seal.

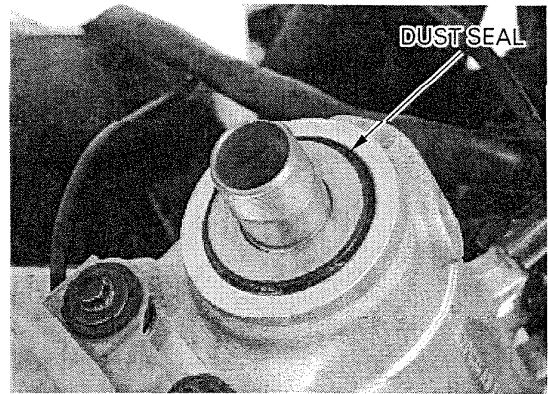

Remove the upper bearing inner race, steering stem, upper and lower steering bearings.

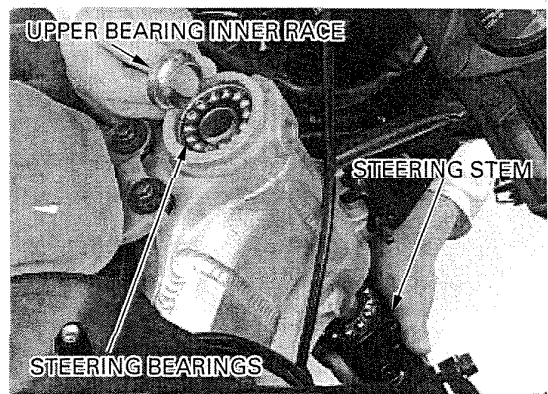

STEERING BEARING REPLACEMENT

Always replace the bearings and races as a set.

Except U.S.A.:
Replace the steering bearing outer races using the ball race remover set

TOOLS:

- | | |
|------------------------------|---------------|
| Ball race remover set | 07946-KM90001 |
| —Driver attachment A (1) | 07946-KM90100 |
| —Driver attachment B (2) | 07946-KM90200 |
| —Driver shaft assembly (3) | 07946-KM90300 |
| —Bearing remover A (4) | 07946-KM90401 |
| —Bearing remover B (5) | 07946-KM90500 |
| —Assembly base (6) | 07946-KM90600 |

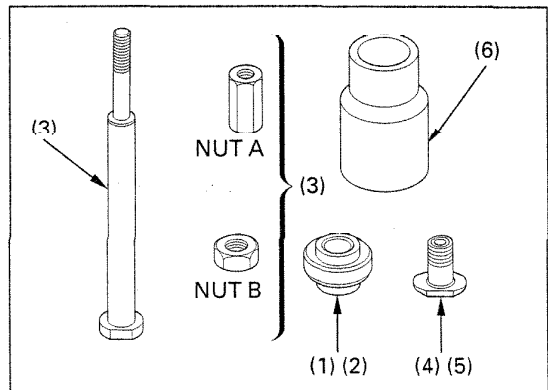

FRONT WHEEL/SUSPENSION/STEERING

Note the installation direction of the assembly base. Install the ball race remover into the steering head pipe as shown.
Align bearing remover A with the groove in the steering head.
Lightly tighten nut B.
While holding the driver shaft, turn nut A gradually to remove the upper bearing outer race.

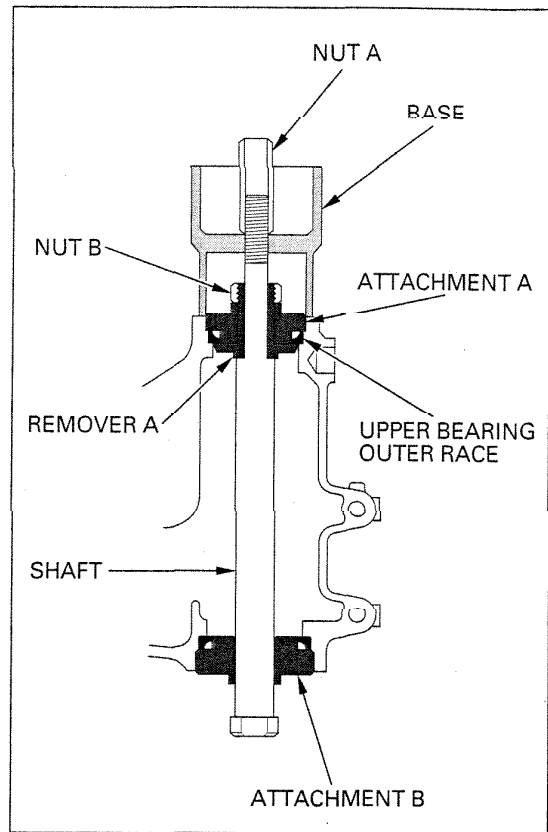

Note the installation direction of the assembly base. Install the ball race remover into the steering head pipe as shown.
Align bearing remover B with the groove in the steering head.
Lightly tighten nut B.
While holding the driver shaft, turn nut A gradually to remove the lower bearing outer race.

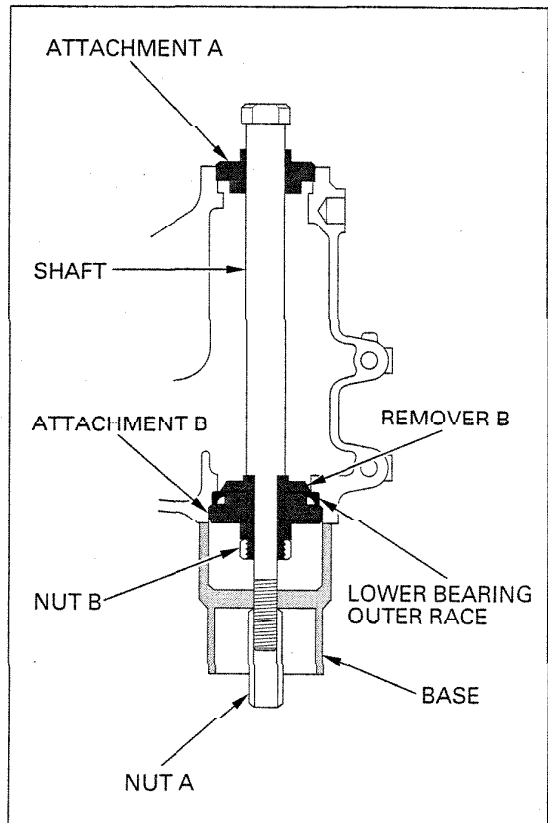

FRONT WHEEL/SUSPENSION/STEERING

Install a new upper bearing outer race and the ball race remover as shown.

While holding the driver shaft, turn nut A gradually until the groove in driver attachment A aligns with the upper end of the steering head. This will allow you to install the upper bearing outer race.

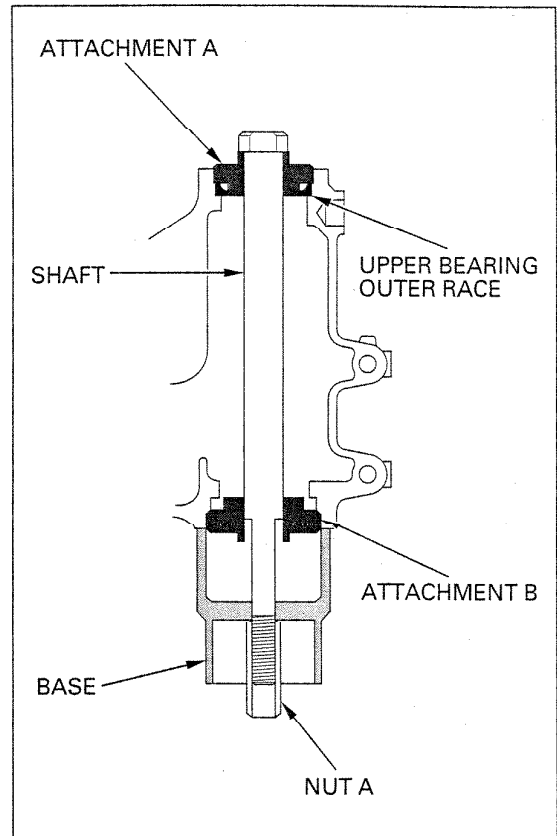

Install a new lower bearing outer race and the ball race remover as shown.

While holding the driver shaft, turn nut A gradually until the groove in driver attachment B aligns with the lower end of the steering head. This will allow you to install the lower bearing outer race.

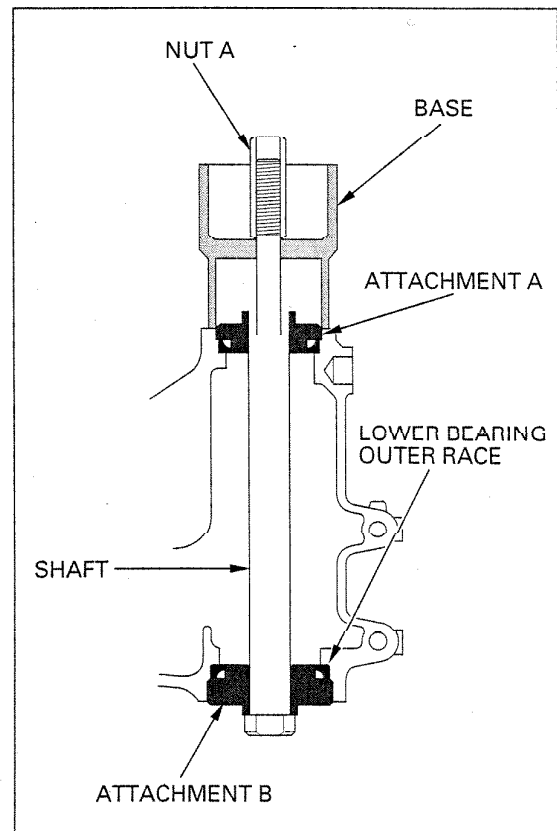

FRONT WHEEL/SUSPENSION/STEERING

U.S.A. only:
 Always replace the bearings and races as a set. Replace the steering bearing outer races using the special tools listed below.

- TOOLS:**
- Main bearing driver attachment 07946-ME90200
 - Fork seal driver weight 07947-KA50100
 - Oil seal driver 07905-MA00000
 - Installer shaft 07VMF-KZ30200
 - Installer attachment A 07VMF-MAT0100
 - Installer attachment B 07VMF-MAT0200
 - Remover attachment A 07VMF-MAT0300
 - Remover attachment B 07VMF-MAT0400

Install the special tools into the steering head pipe as shown.
 Align remover attachment A with the groove in the steering head.
 While holding the installer shaft with the wrench, turn the upper nut gradually to remove the upper bearing outer race.

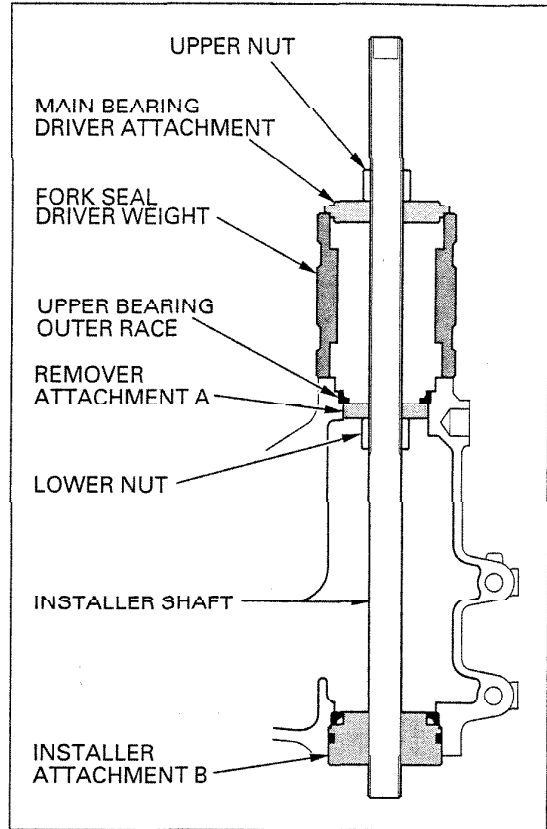

Install the special tools into the steering head pipe as shown.
 Align remover attachment B with the groove in the steering head.
 While holding the installer shaft with the wrench, turn the lower nut gradually to remove the lower bearing outer race.

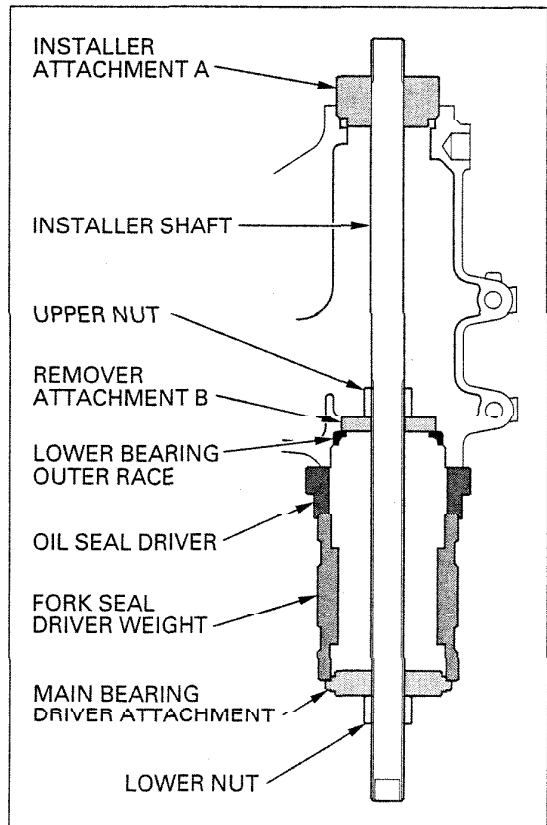

FRONT WHEEL/SUSPENSION/STEERING

Install a new upper bearing outer race and the special tools as shown.

While holding the installer shaft with the wrench, turn the lower nut gradually until the groove in installer attachment A aligns with the upper end of the steering head. This will allow you to install the upper bearing outer race.

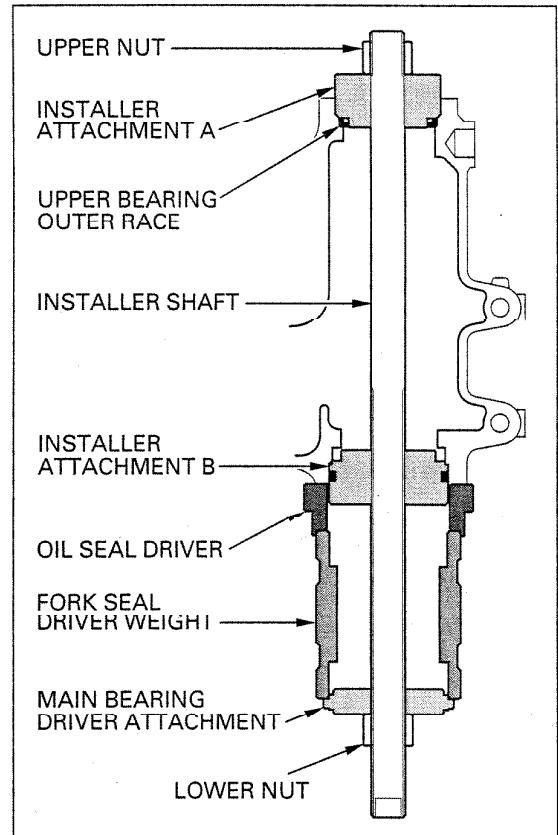

Install a new lower bearing outer race and the special tools as shown.

While holding the installer shaft with the wrench, turn the upper nut gradually until the groove in installer attachment B aligns with the lower end of the steering head. This will allow you to install the lower bearing outer race.

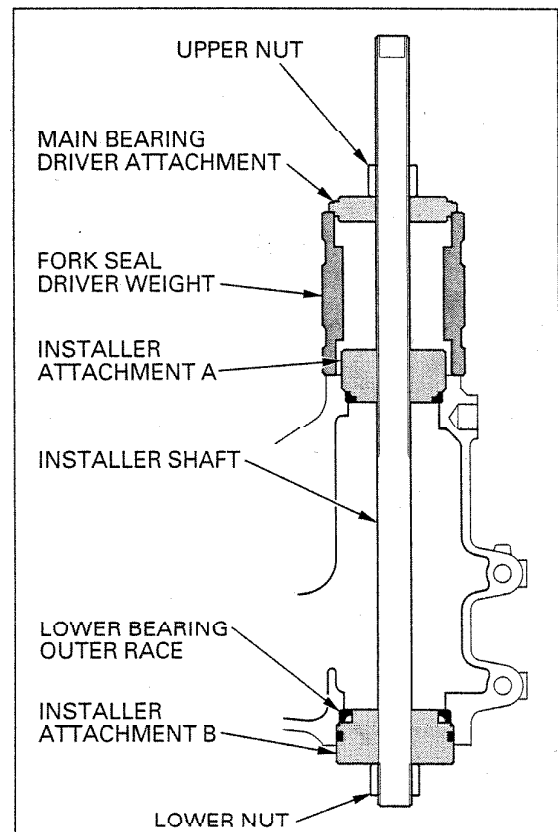

FRONT WHEEL/SUSPENSION/STEERING

Install the stem nut onto the stem to prevent the threads from being damage when removing the lower bearing inner race from the stem.

Remove the lower bearing inner race with a chisel or equivalent tool, being careful not to damage the stem.

Remove the dust seal.

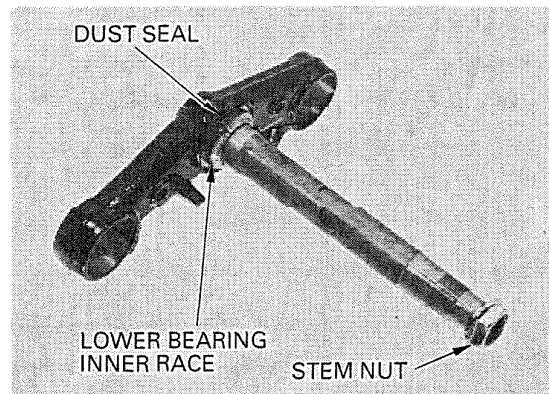

Apply grease to a new dust seal lip and install it to the steering stem.

Press a new lower bearing inner race onto the steering stem using the special tool.

TOOL:

Steering stem driver 07946-MB00000

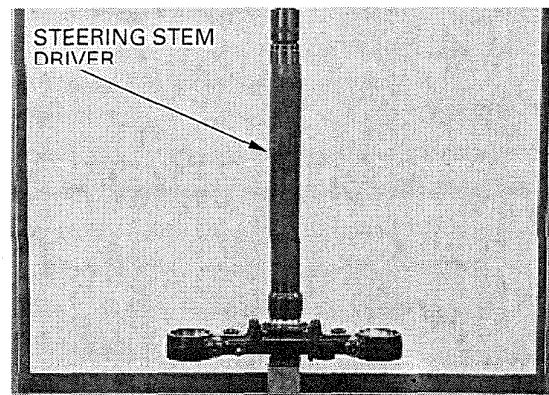

INSTALLATION

Route the cables, wires and hose properly (page 1-18).

Apply grease to the steering bearings and bearing races.

Install the lower bearing onto the steering stem.

Install the steering stem into the steering head pipe.

Install the upper bearing and inner race.

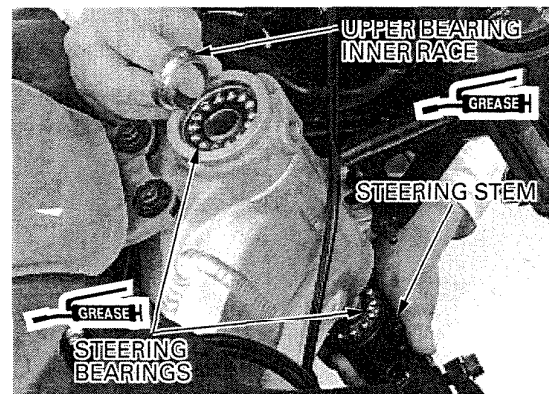

Apply grease to a new dust seal lip and install it.

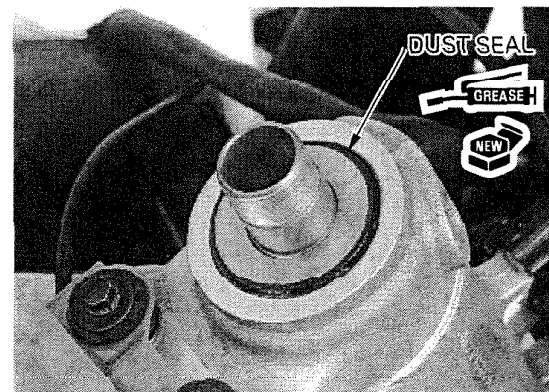

FRONT WHEEL/SUSPENSION/STEERING

Apply oil to the steering bearing adjustment nut threads.

Install and tighten the steering stem adjustment nut.

TOOL:

Steering stem socket 07916-3710101 or
07916-3710100

TORQUE : 25 N·m (2.5 kgf·m , 18 lbf·ft)

Turn the steering stem right and left, lock-to-lock at least five times to seat the bearings.

Retighten the steering stem adjustment nut to the same torque.

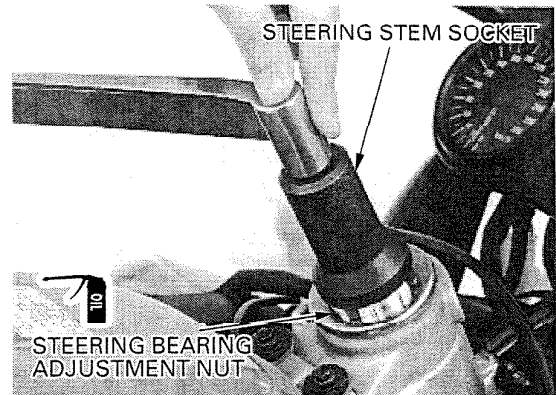

Install a new lock washer and bend the two opposite tabs down into the grooves in the adjustment nut.

Install and finger tighten the lock nut all the way.

Hold the steering adjustment nut and further tighten the lock nut, within 90°, to align its grooves with the tabs of the lock washer.

Bend up the lock washer tabs into the grooves of the lock nut.

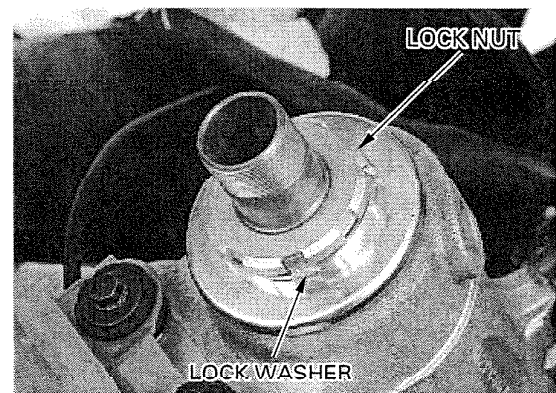

Install the fork top bridge and steering stem nut. Temporarily install the forks into the fork bridges. Tighten the steering stem nut.

TORQUE : 103 N·m (10.5 kgf·m , 76 lbf·ft)

Make sure that the steering stem moves smoothly, without play or binding.

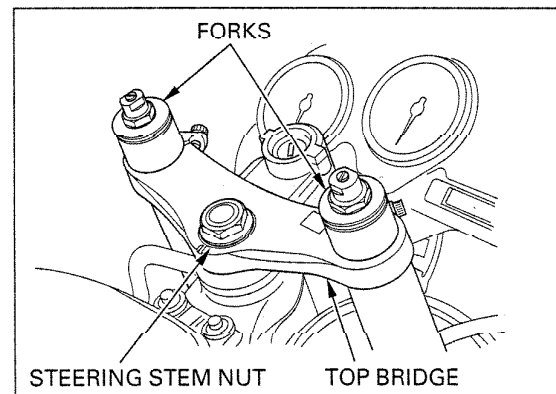

Install the steering stem nut cap.

Install the forks properly (page 13-20).



FRONT WHEEL/SUSPENSION/STEERING

Install the front brake hose clamp and tighten the bolt.

TORQUE : 10 N·m (1.0 kgf·m , 7 lbf-ft)

Install the horn and tighten the bolt.
Connect the horn connectors.

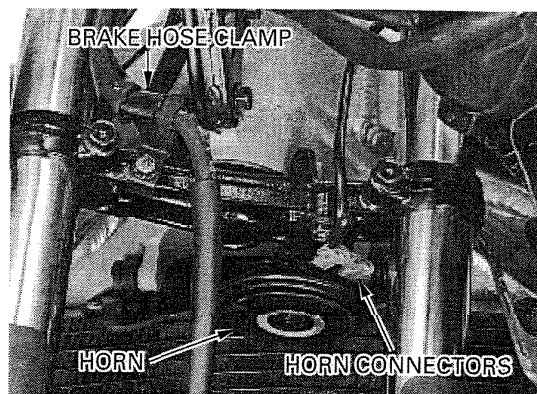

Connect the ignition switch 4P (White) connector and secure the wires with the band (page 1-18).

Install the front wheel (page 13-11).
Install the air intake duct (page 2-6).

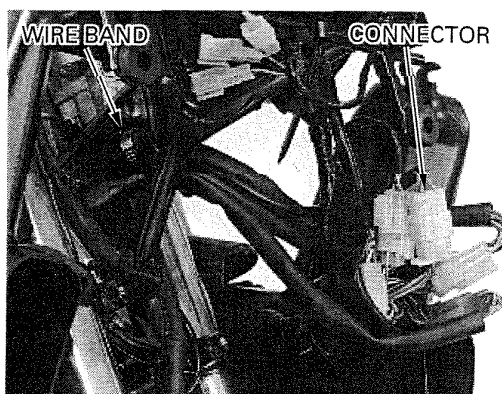

STEERING BEARING PRELOAD

Remove the front fairing (page 2-5).

Support the motorcycle securely using safety stands or a hoist and raise the front wheel off the ground.

Position the steering stem to the straight ahead position.

Hook a spring scale to the fork tube between the fork top and bottom bridges.

Make sure that there is no cable, wire harness or hose interference.

Pull the spring scale keeping it right angle to the steering stem.

Read the scale at the point where the steering stem just starts to move.

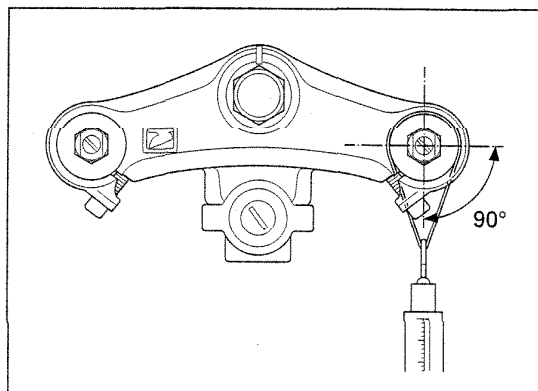

STEERING BEARING PRELOAD:

1.0–1.5 kgf (2.2–3.3 lbf)

If the readings do not fall within the limits, readjust the steering bearing adjustment.

Install the front fairing (page 2-5).